

**RADIO TRANSMITTERS**  
**T-368/URT, T-368A/URT**  
**T-368B/URT, AND T-368C/URT**  
**AND ANTENNA TUNING UNIT**  
**BC-939-B**  
**FIELD AND DEPOT MAINTENANCE**

This copy is a reprint which includes current pages  
from Changes 1 through 3, and 5.

---

*DEPARTMENTS OF THE ARMY AND THE AIRFORCE*  
*DECEMBER 1958*

**WARNING**

**DANGEROUS VOLTAGES EXIST IN THIS EQUIPMENT**

**Be careful when working on the 2,400-volt dc high-voltage circuits, or on the 115-volt ac line connections.**

**DON'T TAKE CHANCES**

**DANGEROUS RF VOLTAGES ARE EXPOSED ON ANTENNA TUNING UNIT BC-939-B  
2,400 VOLTS DC EXIST IN THE FOLLOWING UNITS OF THE RADIO TRANSMITTER:**

**RF DECK**

**MOD DECK**

**HV POWER SUPPLY DECK**

CHANGE }  
No. 5

HEADQUARTERS  
DEPARTMENT OF THE ARMY  
Washington, D.C., 5 October 1965

**DS, GS, AND DEPOT MAINTENANCE MANUAL  
RADIO TRANSMITTERS T-368/URT, T-368A/URT, T-368B/URT, T-368C/URT  
T-368D/URT, AND T-368E/URT; ANTENNA TUNING UNIT BC-939-B; RADIO  
FREQUENCY TUNER TN-339/GR; AND STANDING WAVE RATIO-POWER  
METER ME-165/G**

TM 11-809-35, 8 December 1958, is changed as follows:

*Note.* The parenthetical reference to a previous change (*example:* "page 10 of C 2") indicates that pertinent material was published in that change.

Change the title of the manual as indicated above (page 1 of C 2, 6 Dec 60).

For equipment that have been modified in accordance with MWO 11-5820-258-35/4, move the lead on terminal "D" of J11 to terminal "E" on the following figures (as changed by C 4, 5 Feb 64):

- Page 17, figure 11.
- Page 18, figure 12.
- Page 26, figure 20.
- Page 28, figure 22.
- Page 42, figures 28, 29, 30, and 30.1 (page 10, of C 2)

For equipments that have been modified in accordance with MWO 11-5820 258-35/3, -35/5, and -35/6, delete parallel capacitors "C41" and "C42" (and the value "1,000" where indicated) in the following places:

- Page 14, paragraph 8b, line 8, right column.
- Page 15, figure 9.
- Page 16, figure 10.
- Page 55, figure 42.
- Page 56, figure 43.
- Page 58, figure 45; figure 45.1 (page 4 of C 2).

For equipments that have been modified in accordance with MWO 11-5820-258-35/3, -35/5, or -35/6, change the value of "C7" from "2,000" to 3,900 in the following places:

- Page 15, figure 9.
- Page 16, figure 10.

For equipment modified in accordance with MWO 11-5820-258-35/3, MWO 11-5820-258-35/5, or MWO 11-5820-258-35/6, change connections to SERVICE SELEC-TOR switch S1 (section 4 in A model, section 1 of B through

E models) and relay K9 as shown in figure 30.2 in the following places:

- Page 5, figure 3.
- Page 31, figure 24.
- Page 33, figure 25.
- Page 42, figures 29 and 30 (foldouts), and figure 30.1 ((foldout) page 10 of C 2).
- Page 114, figures 99, 100, and 101 (foldouts), and figures 102 and 103 ((foldouts) page 10 of C 2).
- Page 2, paragraph 1. Make the following changes:

- Delete subparagraph *b*.
- Delete subparagraph *c* and substitute:

*c.* The direct reporting by the individual user of errors, omissions, and recommendations for improving this manual is authorized and encouraged. DA Form 2028 (Recommended Changes to DA Publications) will be used for reporting these improvement recommendations. This form will be completed using pencil, pen, or typewriter and forwarded direct to Commanding General, U.S. Army Electronics Command, ATTN: AMSEL MR-(NMP)-MA, Fort Monmouth, N.J. 07703.

Add paragraph 1.2 after paragraph 1.1 (page 1 of C 2).

**1.2. Index of Publication**

Refer to the latest issue of DA Pam 310 4 to determine whether there are new editions, changes, or additional publications pertaining to the equipment. The pamphlet is an index of current technical manuals, technical bulletins, supply manuals (types 7, 8, and 9), supply bulletins,

**\* This change supersedes C 4, 5 February 1964.**

lubrication orders, and modification work orders that are available through publications supply channels. The index lists the individual parts (-10, -20, -35P, etc) and the latest changes to and revisions of each equipment publication.

*Page 4, paragraph 3c.* Make the following changes:

In line 5, change "B and C models" to B, C, D, and E: models.

Add after first sentence: When K9 is operated, 150 volts applied to tubes V801 and V802 passes through contacts 9 and 10 of slow-release relay K9 (figs. 99, 101, and 103) (in all models except the basic model). The 150 volts is removed from the plates of tubes V801 and V802 when relay K9 is unoperated, which occurs when the transmitter is not keyed. This condition prevents the oscillator radiation during transmitter standby from interfering with the nearby radio receiver (such as Radio Receiver R-390/URR).

*Page 27, figure 21* (as changed by C 4, 5 Feb 64). Delete the terminal letter "D" on J11 and substitute: E.

*Page 29, paragraph 15d, line 11.* After "section 1", add: and contacts 9 and 10 of relay K9.

*Page 32, paragraph 16d, line 7.* After "AM or CW position," add: and contacts 9 and 10 of relay K9.

*Page 40, paragraph 18g(3).* Make the following changes:

Line 20. Change "and contacts 2-3, 4-5, and 6-7 of K9 remain open" to: contacts 3-4, 5 6, 7-8, and 9-10 of K9 remain open.

Line 19, right hand column. Change "Contacts 6 and 7" to: Contacts 7 and 8.

Line 22. Change "Contacts 4 and 5" to: Contacts 5 and 6.

Line 26. Change "contact 5" to: contact 6.

Lines 28 and 31. Change "Contacts 2 and 3" to: Contacts 3 and 4:

Last line. Add after the last sentence of sub-paragraph (3): When the transmitter is not keyed (K9 unoperated), contacts 9 and 10 of relay K9 open the 150-volt circuit used by the plates of master oscillator V801 and first buffer V802 to prevent oscillator radiation from inducing a buzzing tone in a nearby radio receiver.

*Page 41, paragraph 18g(4).* Add after the last sentence: When the transmitter is not keyed (K9 unoperated), contacts 9 and 10 of relay K9 open the 150-volt circuit used by the plates of master oscillator V801 and first buffer V802 to prevent oscillator radiation from inducing a buzzing tone in the nearby radio receiver.

*Page 42.* Add figure 30.2 after figure 30.1 ((foldout page 10 of C 2):



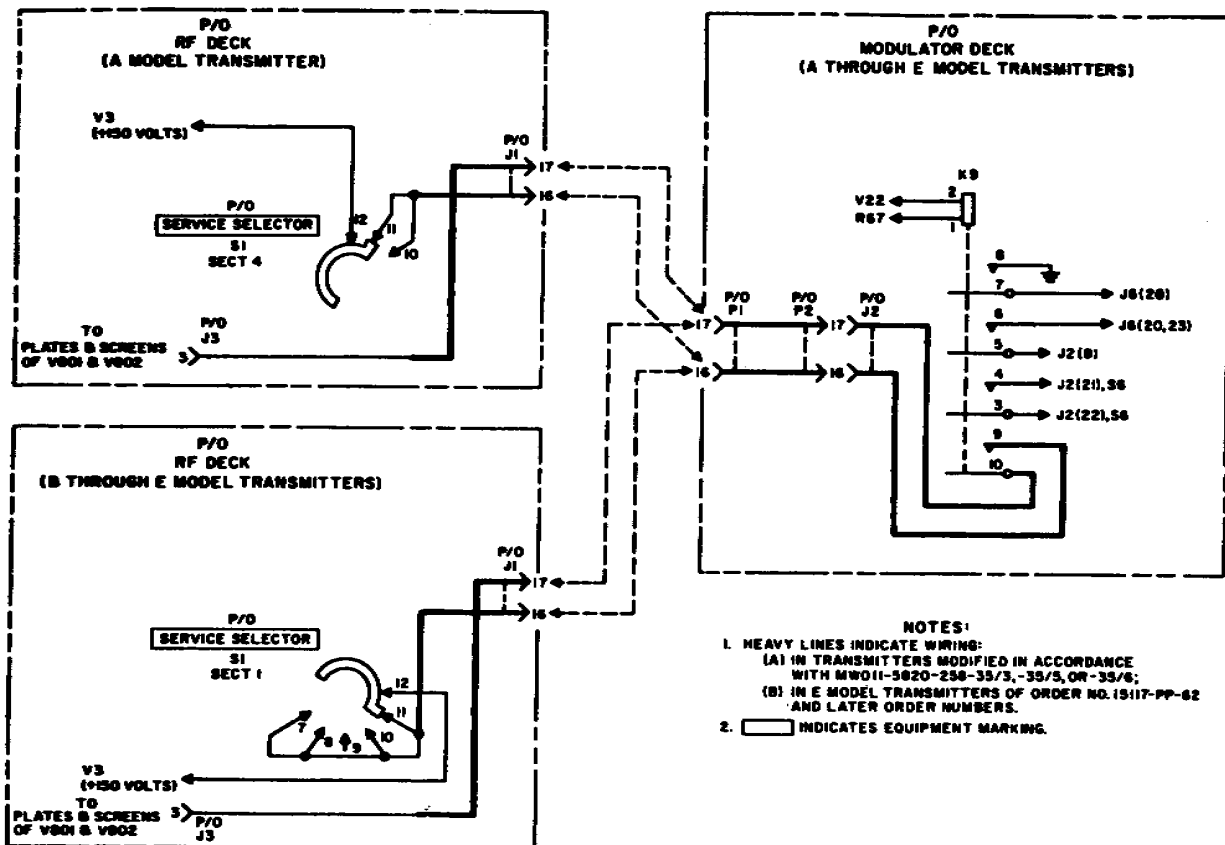

Figure 30.2 Primary power distribution and control circuits, A through E model transmitter changed in accordance with MWO 11-5820-258-35/3, MWO 11-5820-258-35/5, or MWO 11-5820-258-35/6.

Page 43 paragraph 18k(8), line 4. After "AM and CW positions," add: when relay K9 is operated.

Subparagraph 18l (2), line 5. After "(contacts 7, 8, 10, and 11)," add: when relay K9 is operated.

Page 48, chapter 2, warning, last line. Change "stock No. 3F3705-12 19 to :FSN 6625-510-1841.

Page 67, figure 57. Make the following changes:

At pin 3, J1, change "(NOTE 3)" to: (NOTES 3 AND 5).

Add the following note after note 4 (page 3 of C 2):

5. IN EQUIPMENT MODIFIED BY MWO 11-5820-258-35/3, MWO 11-5820-258-35/5, OR MWO 11-5820-258-35/6, THE FOLLOWING READINGS ARE OBTAINED: AT PIN 3, J8, INFINITY FOR ALL SWITCH POSITIONS; AT PIN 16, J1, 20K FOR ALL SWITCH POSITIONS EXCEPT INFINITY FOR EXT EXC POSITION.

Page 93, figure 82 (as changed by C 4, 5 Feb 64).

Make the following changes:

TAGO 5896-A

Delete "NC" at terminal "E" and substitute: OV, 0.

Delete "OV, O" at terminal "D" and substitute: NC.

Page 115, paragraph 59a (page 2 of C 3) and as added by C 4, 5 Feb 64).

Add the following:

Equipment	Federal stock No.	Quantity required	Applicable literature
Frequency Meter AN/USM-26	6625-543-1356	1	TM 11-5057

Paragraph 67 (page 8 of C 3 and as changed by C 4, 5 Feb 64).

Make the following changes:

Subparagraph a, line 2. Change "correct" to: connect.

Add paragraph 67.1 after paragraph 67 (as added by C 4, 5 Feb 64).

## 67.1. Dial Calibration

a. Disconnect plug P10 from J101 and connect it to the SIGNAL INPUT CONNECTOR on the AN/USM-26.

b. Check the accuracy of the dial calibration with the AN/USM-26 at the following frequencies: 1.5 mc, 1.75 mc, 2.0 mc, 2.25 mc, 2.5 mc, 2.75 mc, and 3 mc.

c. The dial indications must be within 0.1 percent of the measured frequencies.

*Page 114*, Make the following changes in the indicated foldout figures.

*Figure 97*. Make the following changes:

Delete capacitors C41 (1,000) and C42 (1,000).

Change the value of capacitor C7 from "2,000" to: 3,900. Next to C7, add: (SEE NOTE 3).

Add the following to the notes:

3. CAPACITOR C7 IS 3,900 UUF IN EQUIPMENT AFFECTED BY THE APPLICATION OF MWO 11-5820-258-35/5.

*Figures 98 and 99* (as changed by C 4, 5 Feb 64). For equipment affected by the application of MWO 11-5820-258-35/4, move the lead on terminal "D" of connector J11 to terminal "E".

*Figure 99*. Make the following changes:

Delete capacitors C42 (1,000) and C42 (1,000).

Change the value of capacitor C7 from "2,000" to: 3,900. Next to C7, add: (SEE NOTE 6).

Add the following to the notes:

5. THE LEAD ON TERMINAL "D" OF CONNECTOR J11 IS MOVED TO TERMINAL "E" IN EQUIPMENT AFFECTED BY THE APPLICATION OF MWO 11-5820-258-35/4.

Add after note 5:

6. CAPACITOR C7 IS 3,900 UUF IN EQUIPMENT AFFECTED BY THE APPLICATION OF MWO 11-5820-258-35/3. REFER TO FIGURE 30.2 FOR OTHER EQUIPMENT CHANGES AFFECTED BY THE APPLICATION OF THIS MWO.

*Figure 100*. Make the following changes:

In the caption, change "B and C model" to: B, C,

and D model.

Delete capacitors C41 (1,000) and C42 (1,000)

Change the value of C7 from "2,000" to: 3,900.

Next to C7, add: (SEE NOTE 8).

Add the following to the notes (page 5 of C1):

8. CAPACITOR C7 IS 3,900 UUF IN EQUIPMENT AFFECTED BY THE APPLICATION OF MWO 11-5820-258-35/3 AND MWO 11-5820-258-35/6. REFER TO FIGURE 30.2 FOR OTHER EQUIPMENT CHANGES AFFECTED BY THE APPLICATION OF THESE MWOS.

*Figure 101*. Make the following changes:

In the figure caption, change "B and C model" to: B, C, and D model.

Delete terminal letter "D" on connector J11 and substitute: E (as changed by C 4, 5 Feb 64).

Add the following to the notes (page 5 of C 1):

7. REFER TO FIGURE 30.2 FOR EQUIPMENT CHANGES AFFECTED BY THE APPLICATION OF MWO 11-5820-258-35/3 AND MWO 11-5820-258-35/6.

*Figure 102* (page 10 of C 2). Make the following changes:

Delete capacitors C41 (1,000) and C42 (1,000).

Change the value of C7 from "2,000" to: 3,900.

Next to C7, add: (SEE NOTE 4).

Add the following to the notes:

4. CAPACITOR C7 IS 3,900 UUF IN EQUIPMENT AFFECTED BY THE APPLICATION OF MWO 11-5820-258-35/5. REFER TO FIGURE 30.2 FOR OTHER EQUIPMENT CHANGES AFFECTED BY THE APPLICATION OF THIS MWO.

*Figure 103* (page 10 of C 2). Make the following changes:

Delete terminal letter "D" on J11 and substitute: E (as changed by C 4, 5 Feb 64).

Add the following to the notes:

4. REFER TO FIGURE 30.2 FOR EQUIPMENT CHANGES AFFECTED BY THE APPLICATION OF MWO 11-5820-258-35/5.

TAGO 5896-A

## APPENDIX

### REFERENCES

---

Following is a list of applicable references available to the direct support, general support, and depot maintenance repairmen of the equipment.

MWO 11-5820-285-35/3	Modification of Transmitters, Radio T-368A/URT, T-368B/URT, T-368C/URT, and T-368D/URT to Eliminate Oscillator Radiation and to Reduce Failure of Coupling Capacitors in the Final Amplifier Plate Circuit.
MWO 11-5820-258-35/4	Modification of Transmitter T-368/URT, T-368B/URT, T-368C/URT, T-368D/URT and T-386E/URT to activate the Microphone Only. When the Push-To-Talk Button is Pressed During AM and FSK-AM Operation.
MWO 11-5820-258-35/5	Modification of Transmitter, Radio T-368C/URT to Eliminate Oscillator Radiation and to Reduce Failure of Coupling Capacitor in the Final Amplifier Plate Circuit and the Time Constant Capacitor in the Keying Diode Circuit.
MWO 11-5820 258-35/6	Modification of Transmitters, Radio T-368/URT and T-368E/URT to Reduce Failure of Coupling Capacitor in the Final Amplifier Plate Circuit and the Time Constant Capacitor in the Keying Diode Circuit.
TM 11-809-10	Operator's Manual: Radio Transmitters T-368/URT, T-368A/URT, T-368B/URT, T-368C/URT, T-368D/URT, and T-368E/URT; Antenna Tuning Unit BC-939B; Radio Frequency Tuner T-339/GR; and Standing Wave Radio-Power Meter ME-165/G.
TM 11-809-20	Organizational Maintenance: Radio Transmitters T-368/URT, T-368A/URT, T-368B/URT, T-368C/URT, T-368D/URT, and T-368E/URT, Antenna Tuning Unit BC-939B; Radio Frequency Tuner TN-339/GR; and Standing Wave Radio-Power Meter ME-165/G.
TM 11-5057	Frequency Meter AN/USM-26.
TM 11-5820-257-12P	Operator and Organizational Maintenance Repair Parts and Special Tool Lists and Maintenance Allocation Chart: Antenna Tuning Units BC-939-A and BC-939-B and Tuner, Radio Frequency TN-339/GR.
TM 11-5820-257-35P	Field and Depot Maintenance Repair Parts and Special Tool List: Antenna Tuning Units BC-939-A and BC-939-B and Tuner, Radio Frequency TN-339/GR.
TM 11-5820-258-20P	Organizational Maintenance Repair Parts and Special Tools List: Radio Transmitter T-368/URT, T-368A, B, C, D, E/URT.
TM 11-5820-258-35P	Field and Depot Maintenance Repair Parts and Special Tool Lists: Radio Transmitters T-368/URT, T-368A/URT, T-368B/URT, T-368C/URT, T-368D/URT, and T-368E/URT.

**By Order of the Secretary of the Army:**

HAROLD K. JOHNSON,  
*General, United States Army,  
Chief of Staff.*

Official:

J. C. LAMBERT,  
Major General, *United States Army*  
*The Adjutant General.*

Distribution:

*Active Army*

USASA (2)	226th USASA Co (5)	USAERDAW (13)
CNGB (1)	251th USASA Co (5)	USACRREL (2)
OC-E (7)	600th USASA Co (5)	MAAG
Dir of Trans (1)	4th USASA Fld Sta (5)	Iran (5)
TSG (1)	12th USASA Fld Sta (5)	Taiwan (5)
CofEngr (1)	13th USASA Fld Sta (5)	Vietnam (5)
CofSptS (1)	14th USASA Fld Sta (5)	USARMIS
USAAESWBD (5)	15th USASA Fld Sta (5)	Honduras (5)
USAARMBD (2)	Svc Colleges (2)	Costa Rica, (5)
UBAARTYBD (2)	Br Svc Sch (2) except	Venezuela (5)
USACDCEA (1)	USAAMS (5)	Paraguay (5)
USACDCCBRA (1)	USASCS (5)	Ecuador (5)
USACDCOA (1)	USAARMS (5)	1st GM Bde (5)
USACDCQMA (1)	USMA (5)	USASETAF (5)
USACDCTA (1)	USAADS (5)	USA Rsch Spt Gp
USACDCADA (1)	USASESCS (60)	(Ft Belvoir) (5)
USACDCARMA (1)	Edgewood Arsenal (5)	KMAG (5)
USACDCAVNA (1)	Redstone Arsenal (5)	JUSMMAT (5)
USACDCARTYA (1)	USATC Armor (2)	JUSMAG, Thailand
USACDCSWA (1)	USATC Engr (2)	USMTMSA (5)
USACDCCEA (1)	USATC Inf (2)	Unita Ord under fol TOE
USACDCCEA	USASTC (2)	(2 cys each) (UNOINDC)
Ft Huachuca (1)	WRAMC (1)	11-5
USACDCEC (10)	Army Pic Cen (2)	11-15
USAMC (5)	Instl (2) except	11-16
USCONARC (5)	Fort Monmouth (70)	11-18
ARADCOM (5)	Fort Gordon (10)	11-32
ARADCOM Rgn (2)	Fort Huachuca (10)	11-35
OS Maj Comd (4)	WSMR (5)	11-37
USAECOM (30)	Fort Caraon (21)	11-38
USASPTCP (11)	Fort Devens (5)	11-39
LOGCOMD (2)	Army Dep (2) except	11-55
USAMICOM (4)	SAAD (30)	11-57
USASMC (2)	TOAD (14)	11-95
USASCC (4)	FTWOAD (10)	11-97
MDW (1)	LEAD (7)	11-98
Armies (5)	SHAD (3)	11-99
Corp (2)	NAAD (5)	11-117
UBAC (3)	SVAD (5)	11-155
11th Air Aslt Div (3)	CHAD (3)	11-157
507th USASA Gp (5)	ATAD (10)	11-237
508th USASA Gp (5)	UMAD (5)	11-247
318th USASA Bn (5)	LBAD (14)	11-337
319th USASA Bn (5)	GENDEPS (2)	11-500 (AA-AE) (4)
320th USASA Bn (5)	Sig Sec GENDEPS (5)	11-527
177th USASA Co (5)	Sig Dep (12)	11-587
182nd USASA Co (5)	Sig Fld Maint Shops (2)	11-592
183rd USASA Co (5)	AMS (1)	11-597
184th USASA Co (5)	USAERDAA (2)	

NG: State AG (3) units-None.

USAR: None

For explanation of abbreviations used, see AR 320-50

**Field and Depot Maintenance Manual**  
**RADIO TRANSMITTERS T-368/URT, T-368A/URT, T-368B/URT, T-368C/URT,**  
**T-368D/URT, and T-368E/URT; ANTENNA TUNING UNIT Bc-939-B;**  
**RADIO FREQUENCY TUNER TN-339/GR; AND STANDING WAVE RATIO-POWER**  
**METER ME-165/G**

TM 11-809-35  
To 31R2-2URT-132  
Changes No. 3



DEPARTMENTS OF THE ARMY  
AND THE AIR FORCE  
WASHINGTON 25, D.C., 28 November 1962

TM 11-809-35/TO 31R2-2URT-132, 8 December 1958, is changed as follows:

Page 115.

**CHAPTER 4**

**DEPOT INSPECTION STANDARDS**  
(Added)

**Section I. GENERAL REQUIREMENTS**

**57. Applicability of Depot Inspection Standards**

The tests outlined in this chapter are designed to measure the performance capability of a repaired equipment. Equipment that is to be returned to stock should meet the standards given in these tests.

*Title*

Operator's Manual: Radio Transmitters T-368/URT, T-368A/URT, T-368B/URT, T-368C/URT, T-368D/URT, and T-368E/URT; Antenna Tuning Unit BC-939-B; Radio Frequency Tuner TN-339/GR; and Standing Wave Ratio-Power Meter ME-165/G.

Organizational Maintenance: Radio Transmitters T-368/URT, T-368A/URT, T-368B/URT, T-368C/URT, T-368D/URT, and T-368E/URT; Antenna Tuning Unit BC-939-B; Radio Frequency Tuner; TN-339/GR; and Standing Wave Ratio-Power Meter ME-165/G.

**58. Applicable References**

TB SIG 355-1, General Standards for Repaired Signal Equipment, forms a part of this Depot Inspection Standard. The following technical publications are applicable to this equipment:

*Number*

*Date*

TM 11-809-10 14 May 1958

TM 11-809-20 2 July 1958

\* These changes replace Signal Corps Repaired Equipment Standard No. REP-1102, Issue No. 2, 9 July 1959.

TAGO 7191A-650578-Dec. 62

*Modification Work Orders.* Perform all applicable modification work orders pertaining to this equipment before making the tests specified. DA Pam 310-4 lists all available MWO's.

### 59. Test Facilities Required

The following equipment, or suitable equivalents, will be employed in determining compliance with the requirements of this specific standard.

#### a. Test Equipment

Equipment	Federal stock No.	Quantity required	Applicable literature
Multimeter TS-362/U .....	6625-242-5023	1	TM 11-5527
Audio Oscillator TS-382/U.....	6625-192-5094	1	TM 11-6625-261-12
Frequency Meter AN/URM-79 .....	6625-668-9749	1	TM 11-5094
Oscilloscope OS-8A/U.....	6625-568-4898	1	TM 11-1214
Standing Wave Ratio-Power Meter ME-165/G .....	6625-682-4464	1	TM 11-809-10
Voltmeter, Meter ME-30A/U.....	6625-669-0742	1	TM 11-6625-320-12

#### b. Additional Equipment.

Equipment	Federal Stock No.	Quantity required
Hand Key KY-116/U .....	5805-503-3395	1
Special Purpose Cable Assembly CX-1862/U.....	5995-349-4844	1
Microphone M-29A/U .....	5965-194-9770	1
Test prod.....	6625-510-1841	1
Resistor (adj) 5,900 ohms 1,600 watts.	(Improvise from appropriate Ohmite Ward Leonard type available or equivalent power resistors).	
Dc ammeter (Use 0-2.5-amp scale on Multimeter T-352/U.		1
Soft copper wire, 2 to 4 turns for rf pickup to oscilloscope (Hookup wire).		2ft
600-ohm resistor, 1 watt, ±5% .....	5906-269-2809	1
200-ohm resistor, 1 watt, ±5% .....	5906-102-2666	1
Headset .....	5965-164-7259	1
Radio Receiver R-390/URR .....	5820-503-1242	1
Exciter O-5C/FR or equivalent .....	5820-556-1993	1
Receiver-Transmitter RT-260/GLQ.-2 .....	5820-351-3298	1

### 60. General Test Requirements

Test conditions are as follows:

a. The power input to terminal J14 of T-368(\*)/URT will be 115 volts ac, 50-60 cps, single phase (approximately 1,570 watts for cw operation and 2,200 watts for am. operation).

b. Connect the M-165/G to T-368(\*)/URT so that one lead connects to J9 (the RF OUTPUT) and the remaining lead of the M-165/G will be connected to the

T-368(\*)/URT(ground). Limit the use of the MW165/G to periods of 3 minutes if used as a dummy load.

c. Tune the T-368(\*)/URT in accordance with the procedure outlined in paragraphs 16 and 17 of TM 11-809-10

d. Align the multiplier subassembly and adjust the speech amplifier, clipper, and sidetone gain control in accordance with the procedure outlined in paragraphs 43, 46, and 55 of TM 11-809-35.

## Section II. INSPECTION PROCEDURES

### 61. Overload Relay Adjustment

*a. CW Overload Relay Adjustment.* Connect the equipment as shown in figure 104. Connect KY-116/U to J11 on T-368(\*)/URT.

- (1) Remove the rear panel. Shunt a jumper across the interlock switch which opened when the rear panel was removed.
- (2) Remove amplifier tube V1 and clamper tube V2 from their sockets.

**Caution:** Be sure that the disconnected plate caps V1 and V2 are insulated from ground to prevent the high-voltage power supply from being short-circuited.

- (3) Set the controls of T-368(\*)/URT for cw operation in accordance with instructions of paragraphs 18 and 19 of TM 11-809-10.

- (4) Adjust the resistance of the dummy load until the dc ammeter (0-2.5 amperes scale on TS 362/U) indicates 0.425 ampere.

(a) PLATE POWER indicator light will go out.

(b) Current reading on dc ammeter will be zero.

- (5) Operate OVERLOAD RESET switch S9. Plate relay K6 will close and reopen immediately.

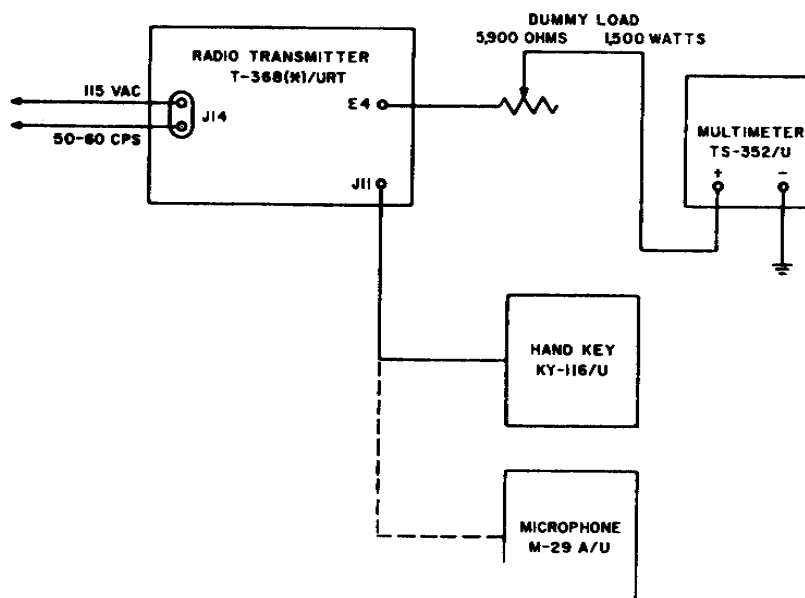

TM809-35-C5-1

*Figure 104. CW overload relay adjustment test setup*

*b. AM Overload Relay Adjustment.* Remove KY-116/U and connect M-29A/U to terminal J11.

- (1) Arrange the controls of T-368(\*)/URT for am operation in accordance with instructions in paragraph 20, TM 11-809-10.

- (2) Adjust the resistance of the dummy load until the dc ammeter (0-2.5 ampere scale on T-352/U) indicates 0.550 ampere.

(a) PLATE POWER indicator light will go out.

(b) Current reading on dc ammeter will be zero.

(3) Remove the dummy load, replace the tubes, remove the jumper from across the interlock switch, and replace the rear panel.

## 62. Output Power Test

Connect the equipment as shown in figure 105.

a. Arrange the TS-382/U for 1 kc at 0.8 volt, as measured on the ME-30A/U.

b. Arrange the T-368(\*)/URT for am operation as outlined in paragraph 20, TM 11-809-10.

c. Adjust the position of the pickup coil to obtain reading of adequate amplitude on the oscilloscope.

d. Adjust the 600 OHM LINE GAIN control for 100 percent modulation as observed on the oscilloscope. The EXCITATION meter on the front panel of T-368(\*)/URT will read 8 ma (min) when the EXCITATION METER SWITCH is put in the P. A. GRID X2 position, and between 20 and 70 ma in the INT AMP PLATE X10 position.

e. With the PA BAND SWITCH set as shown in the following chart, the power will be as indicated.

Band position (mc)	Power on wattmeter (watts min)
1.5-2.0	430
2.0-3.0	430
3.0-6.0	430
6.0-11.0	430
11.0-18.0	430
18.0-20.0	400

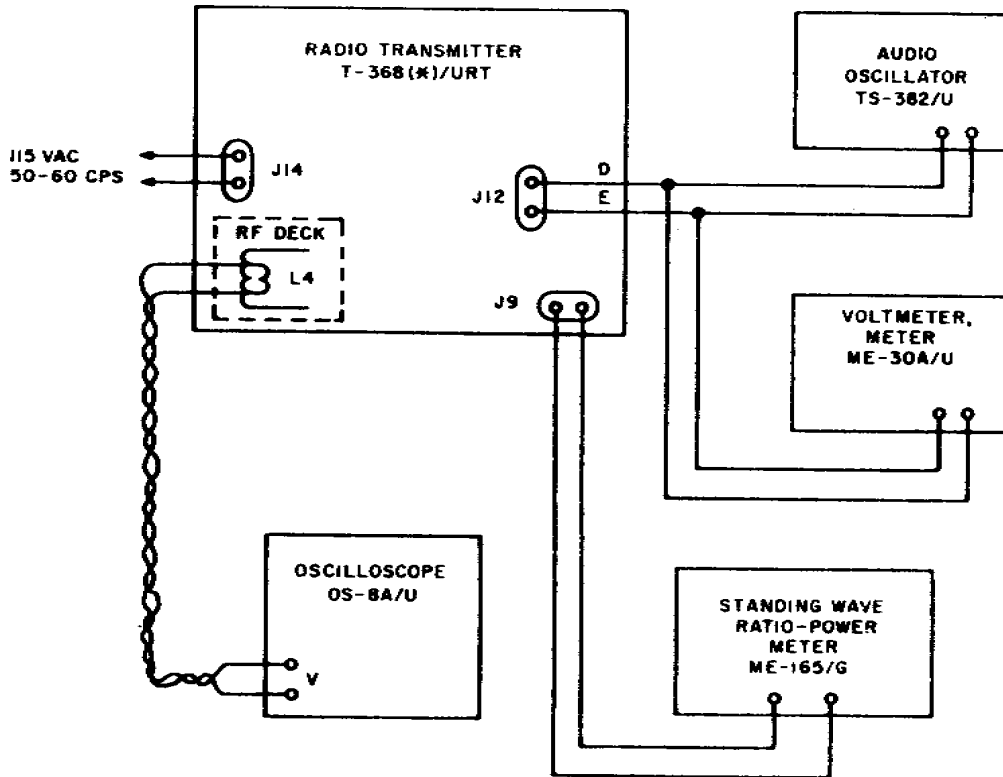

Figure 105. Output power test setup.

TM809-35-C3-2



### 63. Am Modulation Tests

Turn clipper gain control R44 fully counterclockwise (located on speech amplifier subassembly).

*a.* Refer to figure 105 for TS-382/U and OS-8A/U connections. Adjust the TS-382/U for a frequency of 1,000 cycles.

- (1) Set the audio input level to J12 on T-368(\*)/URT, from the TS-382/U at -34 dbm. The ME-30A/U will be used to measure the dbm.
- (2) Turn the CARBON MIKE GAIN control R16 fully counterclockwise.
- (3) Vary the 600 OHM LINE GAIN control R17 an indication of 100 percent modulation is obtained on the OS-8A/U.
- (4) Set the audio input level from the TS-382/U at +6 dbm as recorded on the ME-30A/U, and repeat the procedures given in *a*(2) and (3) above. The OS-8A/U will indicate 100 percent modulation.

*b.* Inject a 1,000-cps signal from TS-382/U into D and E of J12 on T-368(\*)/URT, from across a load resistor used to simulate the characteristics of M-29A/U. Establish an input level of 37 db above 1 millivolt. At this level, and over a range of  $\pm 8$  db, vary the CARBON MIKE GAIN control R16 (used for correction of input level changes). These changes in signal level (of  $\pm 8$  db) will be capable of producing 100 percent modulation.

- (1) Connect M-29A/U to J11. By varying the CARBON MIKE GAIN control R16 while speaking into the M29A/U, it will be possible to modulate 100 percent.
- (2) The above check will be accomplished by observing the amplitude modulated wave on the OS-8A/U. The height of the modulated wave with 100 percent modulation will be twice the height of the unmodulated wave.

TAGO 7191A

$$\% \text{ Modulation} = \frac{H_1 - H_2 \times 100}{H_1 + H_2}$$

$H_1$  = Maximum height of modulated wave

$H_2$  = Minimum height of modulated wave

### 64. Stability Test

Connect the equipment as shown in figure 106.

*a.* Turn the 600 OHM LINE GAIN control R17 fully counterclockwise.

*b.* Turn the CARBON MIKE GAIN control R16 fully clockwise. The modulator plate current indicated on the EXCITATION meter when the EXCITATION METER SWITCH is set at MOD PLATE X20 will not increase.

*c.* Disconnect the 600-ohm resistor from terminal D of J12 on the T-368(\*)/URT and connect the 200-ohm resistor to terminal F of J12.

*d.* Turn the CARBON MIKE GAIN control off.

*e.* Increase the 600 OHM LINE GAIN control to maximum. The static value of the modulator plate current indicated on the EXCITATION meter will not increase.

*f.* Connect KY-116/U to terminal J11.

*g.* Set the controls of T-368(\*)/URT for CW operation as given below:

- (1) SERVICE SELECTOR switch to CW.
- (2) EXCITER PLATE POWER switch (unlettered model only) to OFF. KEYING switch (in lettered models) NORMAL position for CW and am operation.
- (3) PLATE RELAY switch to ON (up).

*h.* Operate KY-116/U rapidly. The PA GRID X2 current indicated on the EXCITATION meter will drop to zero when the key is open. The PA PLATE current will drop to its static value.

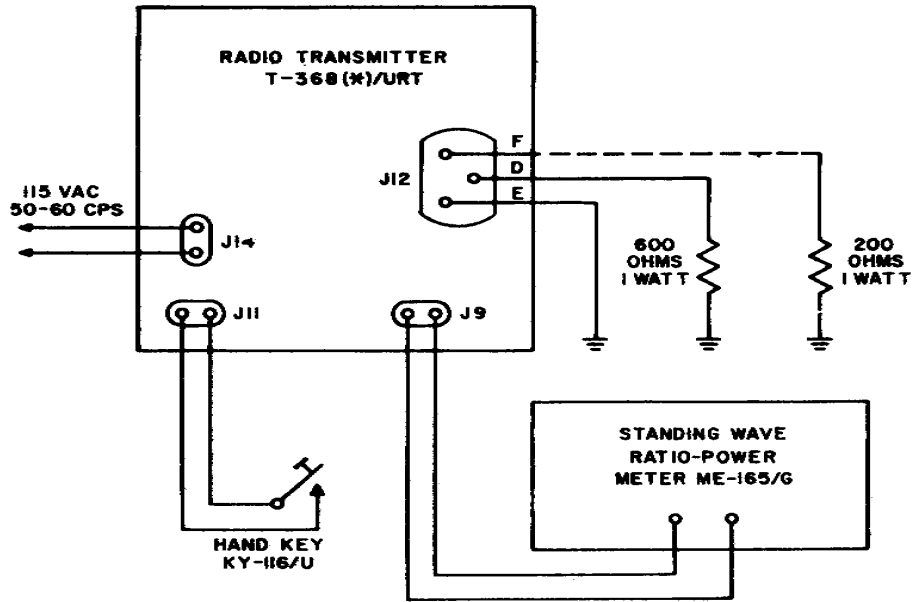

Figure 106. Stability test setup.

TM809-35-C3-3

### 65. Antenna Relay and Receiver Disable Test

Connect the equipment as shown in figure 107.

- a. Set the T-368(\*)/URT controls for CW operation (par. 64g).
- b. Operate the receiver.

c. Key the T-368(\*)/URT by closing KY116/U; the receiver will be disabled and the sidetone will be heard in the monitoring headset. The output of T-368(\*)/URT will be a minimum of 430 watts.

d. Release KY-116/U; the sidetone will cease and the T-368(\*)/URT output will be zero.

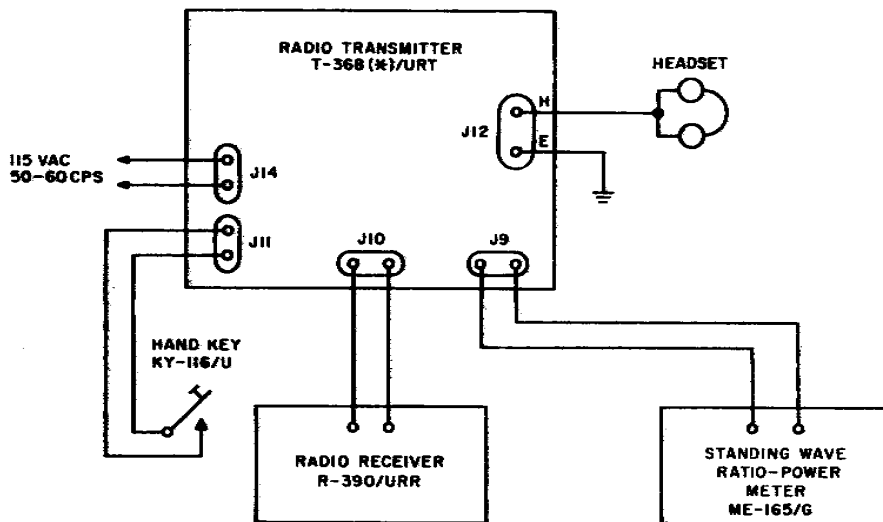

Figure 107. Antenna relay and receiver disable test setup.

TM809-35-C3-4

TAGO 7191A

## 66. FSK Operational and Band Edge Tuning Test

Connect the equipment as shown in figure 108.

a. Set the T-368(\*)/URT controls for FSK operation as follows:

- (1) Turn the SERVICE SELECTOR switch to FSK.
- (2) Connect and turn on the Exciter Unit 0 5C/FR to acquire frequency shift.

- (3) Turn the EXCITER PLATE POWER switch (on unlettered models) to on (up) and turn the KEYING switch (in lettered models) to KEYING CONTINUOUS.
- (4) Set the EXCITATION METER SWITCH to the PA GRID X2 position. The meter will now indicate grid current.
- (5) Turn PLATE RELAY switch on (up).

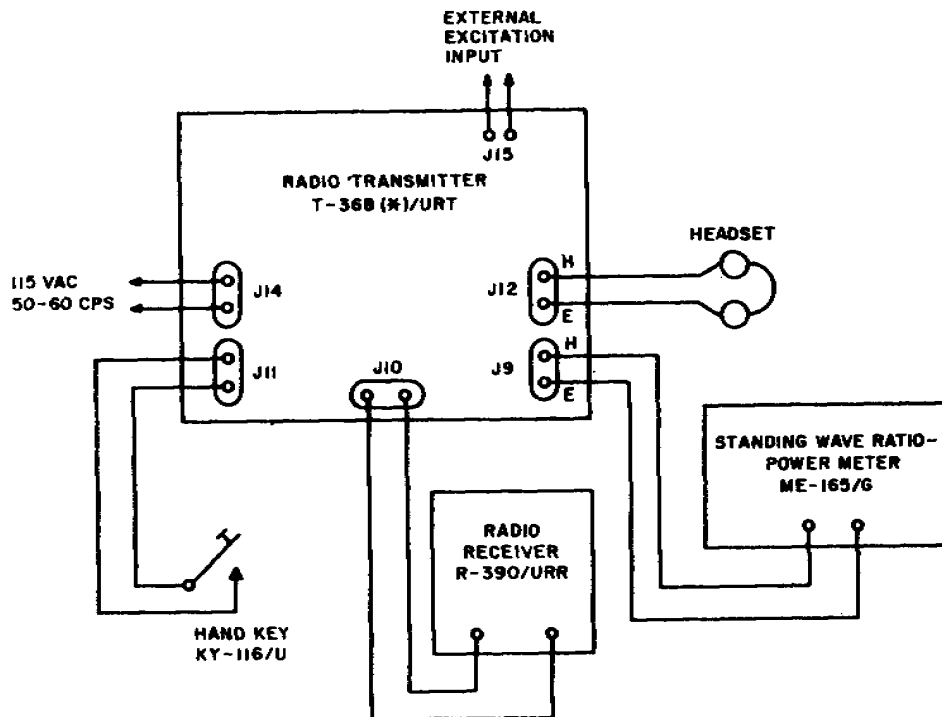

Figure 108. FSK operational and band edge tuning test setup.

TM809-35-C3-5

b. Apply FSK signals with a maximum of 5 volts to the T-368(\*)/URT at the frequencies and control settings listed in table II. The output frequencies will be checked with Frequency Meter AN/URM-79.

c. The output power will be as indicated in the chart below.

*Note* When changing the T-368(\*)/URT operating frequency, throw the TUNE OPERATE switch to TUNE (in A and C models, OPERATE position is labeled NORMAL) while adjusting the POWER AMPLIFIER TUNING and POWER AMPLIFIER LOADING controls. Make all measurements at the OPERATE position.

Input freq. mc	Band selector switch	P.A. Band switch mc	Output freq.	Minimum output power watts
1.500	1.5-3.0	1.5-2.0	1.600	430
2.025	1.5-3.0	1.5-2.0	2.025	430
1.975	1.5-3.0	2.0-3.0	1.975	430
2.975	1.5-3.0	3.0-60	2.975	430
3.025	1.5-3.0	2.0-3.0	3.025	430
5.975	3.0-6.0	6.0-11.0	5.975	430
6.025	3.0-6.0	3.0-6.0	6.025	430
5.5125	6.0-12.0	6.0-11.0	11.025	430
5.4875	6.0-12.0	11.0-20.0	10.975	430
5.00625	12.0-20.0	11.0-20.0	20.025	400

### 67. External Excitation Operation

*a.* Disconnect the FSK Exciter Unit O-5C/ FR and correct the Receiver-Transmitter RT-260/GLQ-2 to terminal J15 of the T-368(\*)/ URT.

*b.* Set the T-368(\*)/URT controls for EXT EXC operation as per paragraph 21 of TM 11-809-10.

*c.* Apply a maximum of 25 volts rf input to T-368(\*)/URT terminal J15.

*d.* The output will be at least 430 watts as read on the wattmeter. The output power will be checked on the 3-6 mc band.

### 68. Speech Clipper Test

*a.* Set the T-368(\*)/URT controls for AM. Operation as outlined in paragraph 61 *a.*

*b.* Connect the M-29A/U to T-368(\*)/URT terminal J11. Press the push-to-talk button on the M-29A/U and speak into the M-29A/U while varying the CARBON MIKE GAIN control over its entire range. The modulator plate current reading on the Excitation meter will not be more than 230 ma for any setting of the CARBON MIKE GAIN control.

### 69. Safety Test

Remove high voltage from the T-368(\*)/URT by throwing FILAMENT POWER and PLATE POWER circuit breakers to OFF. Short circuit with test prod from high voltage to chassis in order to safely perform the following procedures.

*a.* Connect the high-voltage probe of Multimeter TS 352/U to the high-voltage bus in the T-368(\*)/URT power supply deck.

*b.* Throw the PLATE POWER circuit breaker to on and the PLATE RELAY switch to ON (up). Apply FILAMENT POWER; the time relay will operate in approximately 25 seconds after the filament power is turned on. The presence of high voltage is indicated by a reading on the voltmeter and the POWER INDICATOR light going on.

*c.* Slide out each deck of the T-368(\*)/URT in turn. When a deck is withdrawn about 1 inch, the opening of the interlock switch will remove the high voltage as indicated by the PLATE POWER indicator light going out and the voltmeter indicating 0.

*d.* Repeat the procedures given in *a* through *c* above with the high-voltage probe of the voltmeter connected to the modulator and to the rf deck side of the high-voltage bus.

*e.* Repeat the procedures given in *a* through *c* above. Remove the back cover of the housing to remove the high voltage. Throw the PLATE POWER circuit breaker and the PLATE RELAY switch to OFF.

*f.* Operate the FILAMENT POWER circuit breaker; note that the blower operates only when the circuit breaker is in the ON position.

*g.* Turn off all circuit breakers and switches.

### 70. Operational Test

*a.* Remove test Receiver R-390/URR a sufficient distance from the T-368(\*)/URT to prevent blocking.

*b.* The transmitted signal will be received in a clear and intelligible manner. There will be no cracking or buzzing noises that indicate high-voltage arcing.

BY ORDER OF THE SECRETARIES OF THE ARMY AND THE AIR FORCE

Official:

J. C. LAMBERET,  
*Major General, United States Army,  
The Adjutant General.*

EARLE G. WHEELER,  
*General, United States Army,  
Chief of Staff.*

Official:

R. J. PUGH,  
*Colonel, United States Air Force,  
Director of Administrative Services.*

CURTIS E. LEMAY,  
*Chief of Staff,  
United States Air Force.*

Distribution:

*Active Army*

DASA (6)  
USASA (2)  
CNGB (1)  
CSigO (6)  
CofEngrs (1)  
CofT (1)  
TSG (1)  
USA Engr CD Agcy (1)  
USA CBR CD Agcy (1)  
USA Comm CD Agcy (1)  
USA Elct CD Agcy (1)  
USA Med CD Agcy (1)  
USA Ord CD Agcy (1)  
USAQM CD Agcy (1)  
USA Trans CD Agcy (1)  
USA Arty CD Agcy (1)  
USA Armor CD Agcy (1)  
USA Inf CD Agcy (1)  
USA AD CD Agcy (1)  
USA SPWAR CD Agcy (1)  
USA Avn CD Agcy (1)  
USAATBD (1)  
USCONARC (6)  
ARADCOM (2)  
ARADCOM Rgn (2)

LOGCOMD (5)  
MDW (1)  
Armies (1)  
Ft Mommouth (87)  
USATC AD (2)  
USATC Engr (2)  
USATC Inf (2)  
USATC Armor (2)  
GENDEP (OS) (2)  
Sig Sec, GENDEP (OS) (10)  
A Dep (2) except  
Atlanta (None)  
Dep (OS) (2)  
USA Strat Comm Comd (4)  
USAOMC (4)  
Def Log Svc Cen (1)  
USAEPG ( 1 )  
USA Sig Msl Spt Agcy (2)  
USA Elct Mat Agcy (25)  
USA Elct Mat Agcy, MRO (1)  
USA Corps (3)  
Units org under fol TOE  
11-587 (2)  
11-592 (2)  
11-597 (2)

*NG:* None.

*USAR:* None.

For explanation of abbreviations used, see AR 320-50.

**TAGO 7191A**

**Field and Depot Maintenance Manual  
RADIO TRANSMITTERS T-368/URT, T-368A/URT, T-368B/URT,  
T-368C/URT, T-368D/URT, AND T-368E/URT; ANTENNA  
TUNING UNIT BC-939-B; RADIO FREQUENCY TUNER TN-339/GR;  
AND STANDING WAVE RATIO-POWER METER ME-165/G**

**TM 11-809-35  
TO 31R2-2URT-134  
Changes No 2**



**DEPARTMENTS OF THE ARMY  
AND THE AIR FORCE  
WASHINGTON 26. D. C., 6 December 1960**

TM 11-809-35/TO 31R2-2URT-134, 8 December 1958, is changed as indicated so that the manual also applies to Transmitter, Radio T-368E/URT, and Standing Wave Ratio-Power Meter ME-165/G procured on Orders No. 3219-PP-59 and 3241-PP-59.

*Note.* Parenthetical reference to previous Changes (example: "page 2 of C 1") indicates that pertinent information was published in that Changes.

Change the title of the manual to: FIELD AND DEPOT MAINTENANCE MANUAL, RADIO TRANSMITTERS T-368/URT, T-368A/URT, T-368B/URT, T-368C/URT, T-368D/URT, AND T-368E/URT; ANTENNA TUNING UNIT BC-939-B; RADIO FREQUENCY TUNER TN-339/GR; AND STANDING WAVE RATIO-POWER METER ME-165/G.

Add the following note to figure 36.1 (page 3 of C 1), figure 95.1 (page 4 of C 1), and figure 95.2 (page 5 of C 1):

REFERENCE DESIGNATIONS APPLY TO MATCHING UNITS ON ORDERS PRIOR TO ORDERS NO. 3219-PHILA-59 AND 3241-PHILA-59. REFER TO TEXT FOR DIFFERENCES.

Page 2, chapter 1 (page 1 of C 1). Delete the note below the title and substitute:

*Note.* Radio Transmitters T-368D/URT and T-368E/URT are similar to Radio Transmitter T-368C/URT. Reference to the C model also applies to the D and E models unless otherwise specified. Paragraph 1. Add paragraph 1.1.

**1.1. Difference in Equipments**

Standing Wave Ratio-Power Meters ME 165/G on Orders No. 3219-Phila-59 and 3241-Phila-59 are similar in purpose, operation and appearance to those on

previous orders. They differ only in some part reference designations. The differences are indicated in the chart below. All reference designations not listed are identical for all units.

Reference designations ME-166/G. all orders prior to No. 3219-PP-59	Corresponding Reference Designations, ME-165/G on Orders No. 8219-PP-59 and 8241-PP-59
C3	C4
C4	C5
C5	C6
C6	C7
C7	C8
C8	C1
C9	C2
C10	C3
CR1	CR2
CR2	CR1
R13	R20
R14	R21
R15	R13
R16	R22
R17	R23
R18	R14
R19	R15
R20	R16
R21	R17
R22	R18
R23	R19

Page 8, paragraph 7. Heading, change "(figs. 7 and 8)" to: (figs. 7, 8, and 8.1).

Page 11, paragraph 7c, line 4. After "K101" add: in E model transmitters, + 13 volts is supplied from a bridge rectifier network (CR1 to CR4) to energize relay K101.

Page 13, figure 8. Delete the caption and substitute: *Intermediate power amplifier stage protective relay circuit, A through D model transmitters.*

Page 36, paragraph 18. Make the following changes:  
 Heading. Change "(figs. 28-30)" to: (figs. 28-30 and 30.1).  
 Subparagraph a, right-hand column, line 8.  
 Change "(figs. 29 and 30)" to: (figs.

29, 30, and 30.1).  
 Line 22. After "K101" add. in the E model transmitters, a bridge rectifier circuit across the 26.5-volt secondary of transformer T1 supplies dc control voltages for energizing antenna changeover

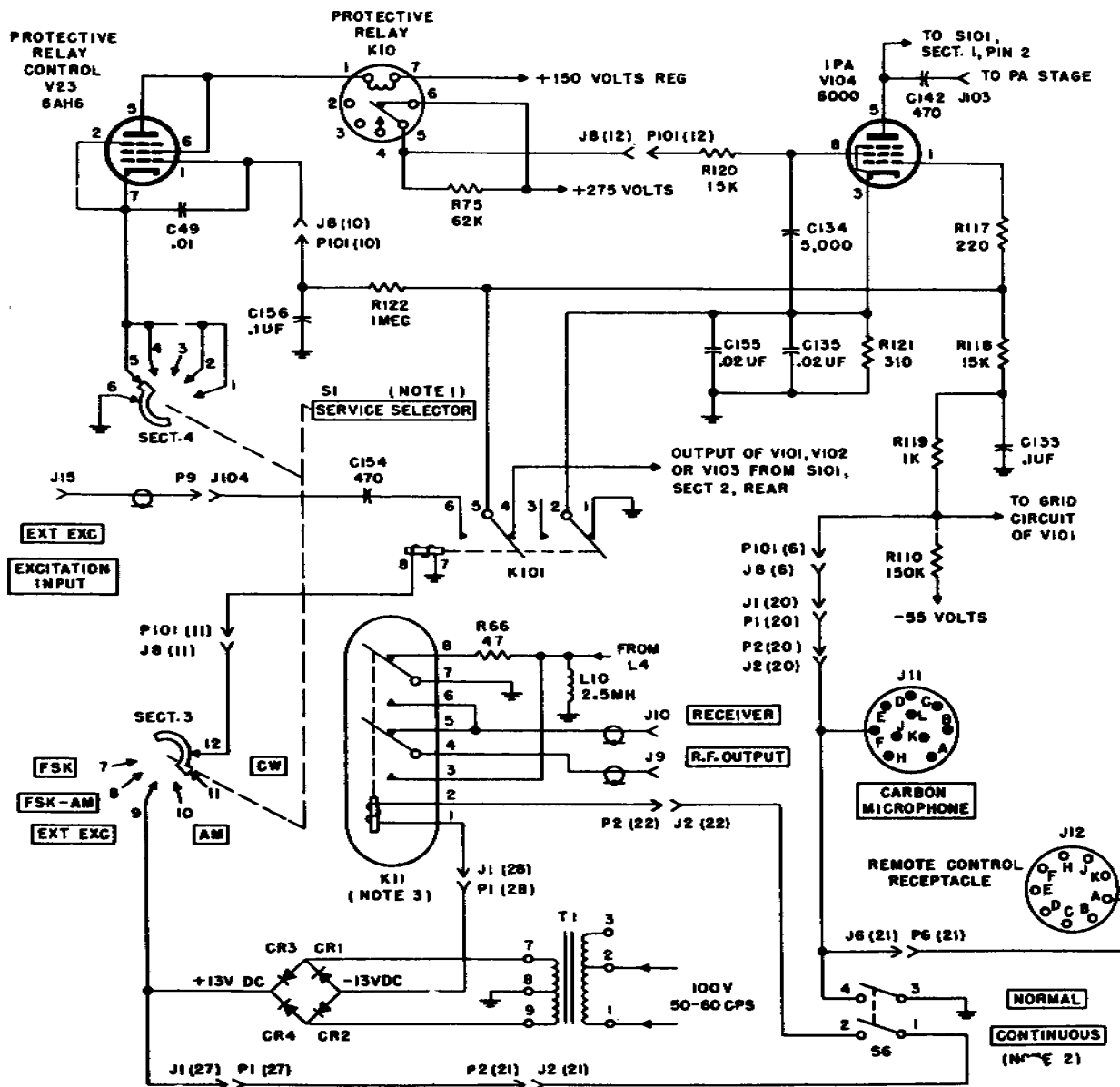

NOTES:

1. SERVICE SELECTOR SWITCH IS SHOWN IN CW POSITION.
2. KEYING SWITCH IS SHOWN IN NORMAL POSITION.
3. ANTENNA CHANGEOVER RELAY K11 IS A VACUUM RELAY.

TM 809-35-C2-4

Figure 8.1. (Added) Intermediate power amplifier stage protective relay circuit, E model transmitters.

relay K11 and external excitation relay K101.

Page 37, paragraph 18b, lines 17 and 18. Change "B and C model transmitters (fig. 30)" to: B, C, and D model transmitters (fig. 30) and E model transmitters (fig. 30.1).

Page 38, paragraph 18f(2). Change the heading to: *A through D model transmitters*.

Page 39, paragraph 18f(2). Add subparagraph (3).

- (3) *E model transmitters* (fig. 30.1). Antenna changeover relay K11 is a glass inclosed vacuum relay in the E model transmitters, and its function is the same as in the other lettered-model transmitters described in (2) above. The antenna relay is energized by 13 volts dc during key-down periods of transmission. This dc voltage is obtained from a bridge rectifier circuit (CR1 through CR4) which is connected across the 26.5-volt ac secondary winding (terminals 7 and 9) of transformer T1. Relay K11 is energized through contacts 3 and 4 of slow-release relay K9 (for AM or CW operation), or through contacts 1 and 2 of the KEYING switch (CONTINUOUS position) for FSK-AM, FSK, or EXT EXC operation.

Page 40, paragraph 18g(4). Change the heading to: *B through E model transmitters* (figs. 30 and 30.1).

Page 41, paragraph 18i, line 4. After "from T1" add: in the E model transmitter, one side of the relay coil (terminal 7) is grounded, and the relay is energized, when the SERVICE SELECTOR switch is in the EXT EXC position, by 13 volts dc from rectifiers CR1 through CR4.

Figure 30.1. (Added) *Primary power distribution and control circuits, E model transmitters*.

**(Located in back of these changes)**

Page 43, paragraph 18I. Change the heading to: *SERVICE SELECTOR Switch S1 in B through E Model Transmitters* (figs. 30 and 30.1).

Paragraph 19, heading. Change "(figs. 28-30)" to: (figs. 28-30 and 30.1).

Page 44, paragraph 19, next to the last line. After "I 4" add: (DS4 in D and E model transmitters).

Page 46, paragraph 23.2 (page 2 of C 1). Add the following note below the heading:

*Note.* Reference designations used in this section apply to matching units on orders prior to Orders No. 3219-Phila-59 and 3241-Phila-59. Refer to paragraph 1.1 for differences. Subparagraph *a* (page 2 of C 1). In the last sentence, change "C17" to: C7.

Page 49, paragraph 26, chart. In "Fig. No." column, make the following changes:

Line 3. Add "45.1" after "42-45."

Line 6. Add "50.1" after "49-52."

Line 7. Add "56.1" after "60-63."

Line 10. Add "83.1" after "83."

Line 11. Add "84.1" after "84."

Line 13. Add "88.1" after "87-88."

Page 54, figure 41 (page 3 of C 1). Line 2 of note after "39692-PHILA-58" add: AND IN E MODEL TRANSMITTERS.

Page 62, figure 50. Add "*basic model and A through D model transmitters*" to the caption.

Page 67, figure 57. Make the following changes:

Below the lines from pins 27 and 28 of J1, add: (NOTE 4).

Add the following to the notes:

4. IN E MODEL TRANSMITTERS, PINS 27 AND 28 OF J1, ARE EACH 5.5 OR INFINITY, DEPENDING ON THE POLARITY OF THE METER LEADS. IN EXT EXC POSITION, PIN 27 OF J1 IS 5.5 OR 88.

Page 80, figure 72. Delete note 7 and substitute:

7. RESISTANCE READINGS MADE WITH P3, P4, AND P5 REMOVED FROM J3, J4, AND J5.

Page 85, paragraph 31. Add the following note to paragraph 31 before the troubleshooting chart:

*Note.* All information pertaining to I4 in the chart is referenced as DS4 in D and E model transmitters.

Paragraph 31 (page 3 of C 1). "Correction" column. After "I 4", delete "(DS4 in D model transmitters)."

Page 94, paragraph 32b, chart, "Relay reference symbol" column. Make the following changes:

Change "K6" to: K6 (basic, A through D models)

Under "K6 (basic, A through D models)" add: K6 (E model). In "Dc resistance (ohms)" column, add: 220.

Under "K11 (B and C models)" add: K11 (E model). In "Dc resistance (ohms)" column, add: 240.



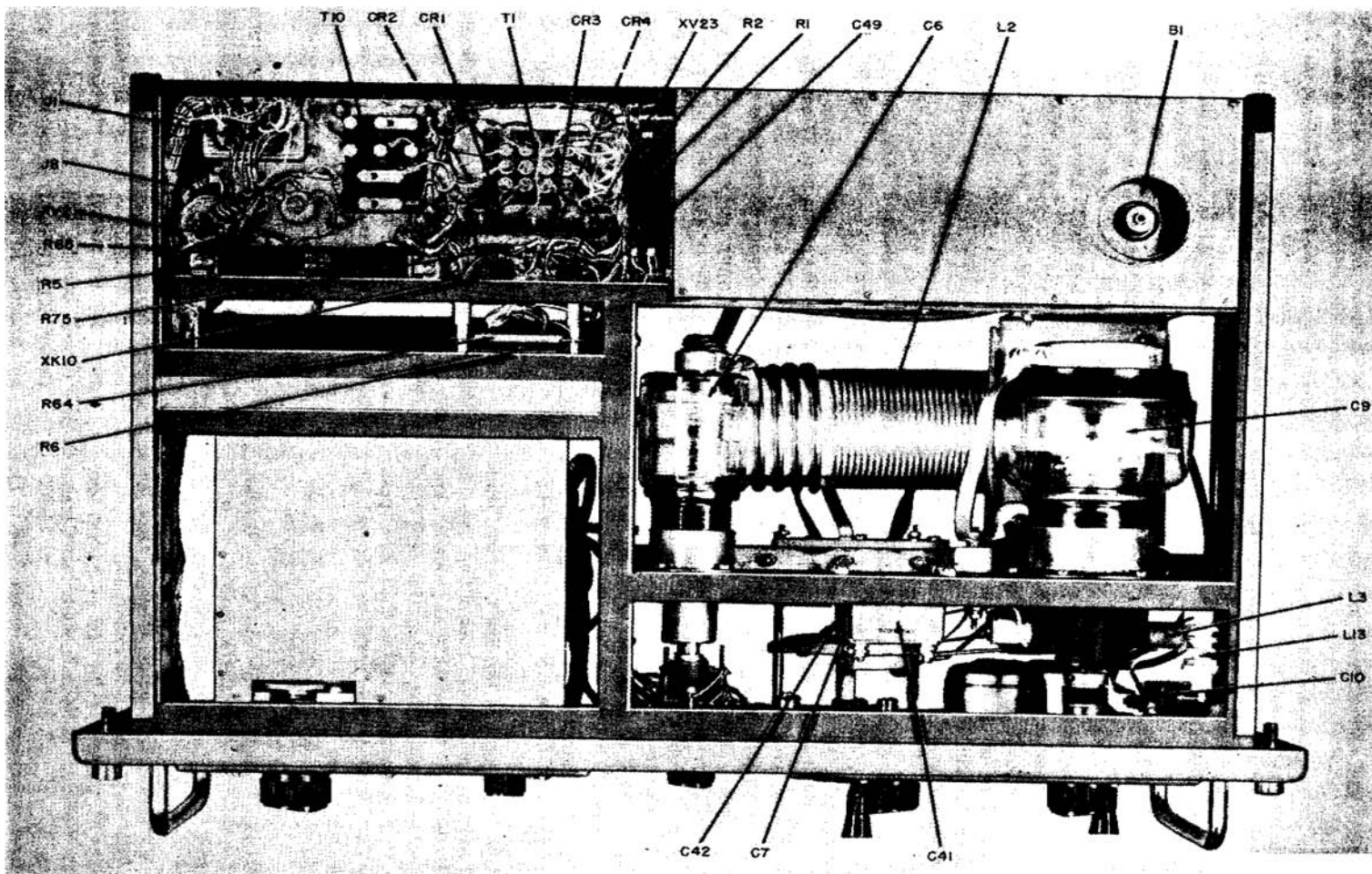

Figure 45.1. (Added) Rf deck of E model transmitters, bottom view.

AGO 3257

Change "K101" to: K101 (basic, A through D models).

Under "K101 (basic, A through D models)" add: K101 (E model).

In "Dc resistance (ohms)" column, add: 75.

Page 95, figure 83. Add "basic model and A through D model transmitters" to the caption.

Page 96, figure 84. Add the following to the caption: basic model and A through D model transmitters.

Figure 85. Add "basic model and A through D model transmitters" to the caption.

Page 99 figure 88. Delete the caption and substitute: Transmitter housing, decks removed, A through D model transmitters.

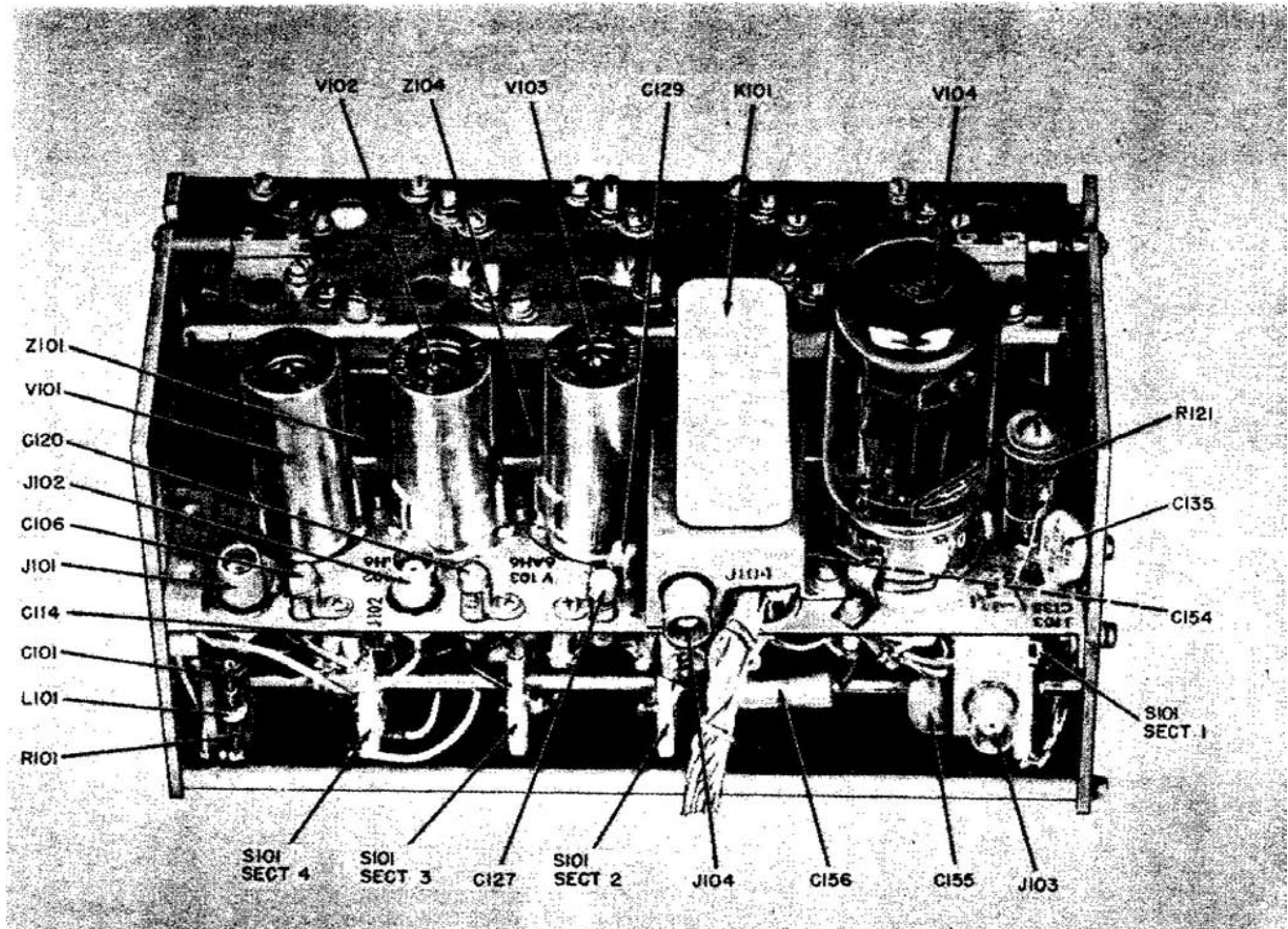

Figure 50.1. (Added) Multiplier subassembly, side view, E model transmitters.

AGO 3257A

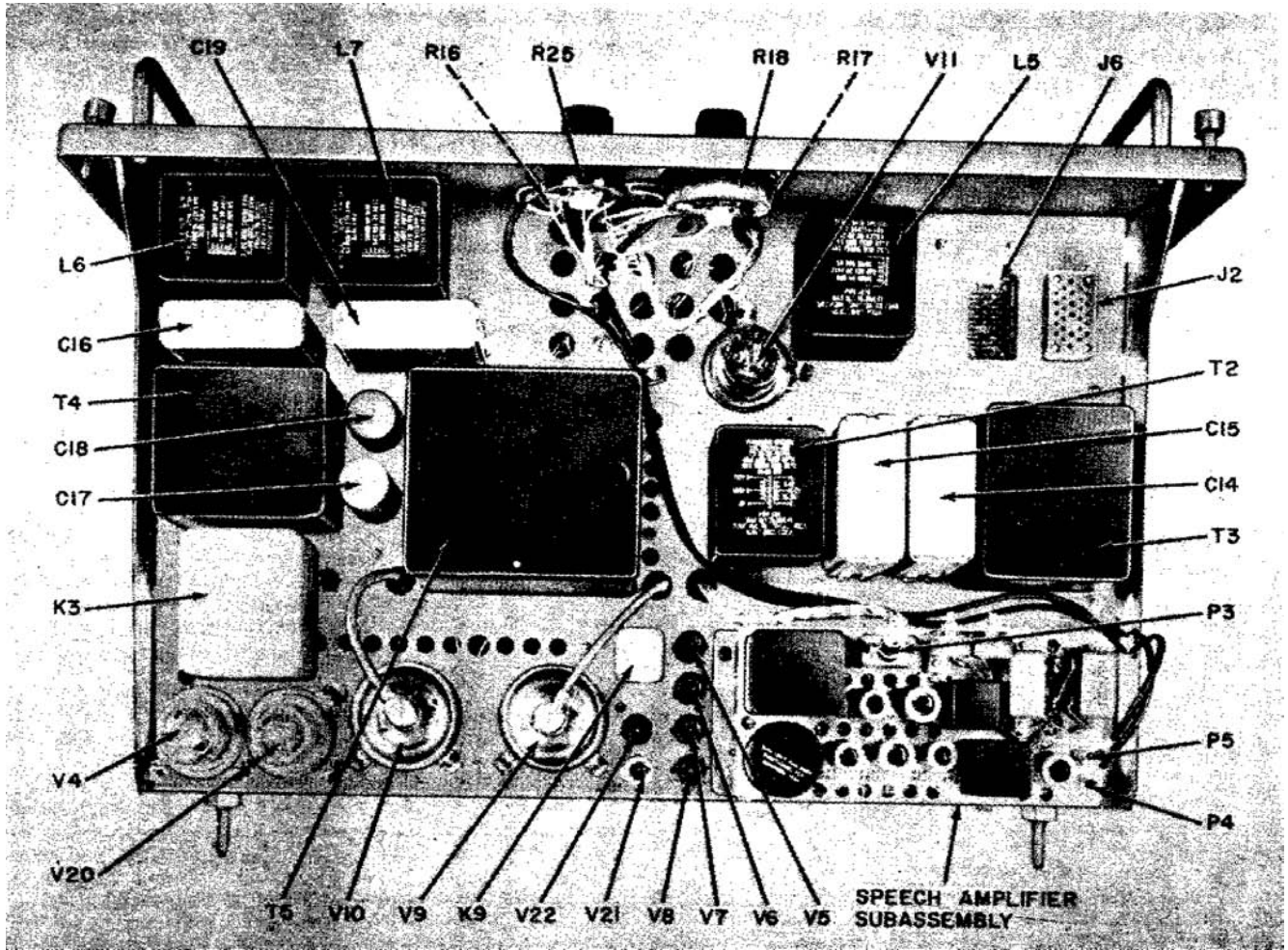

Figure 63.1. (Added) Modulator deck, top view, E model transmitters.

AGO 3257 A

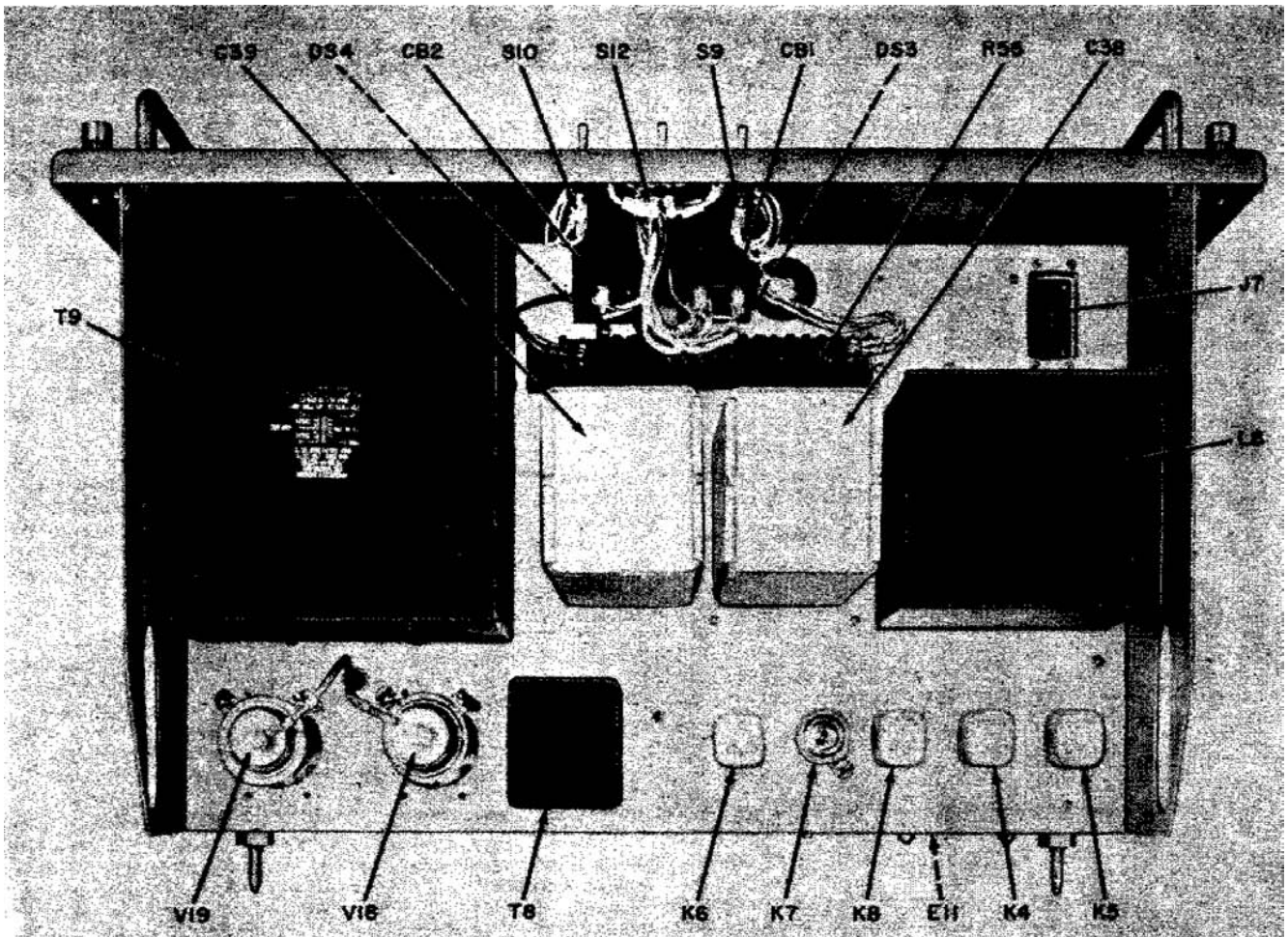

Figure 83.1 (Added) Power supply deck, E model transmitters, top view.

AGO 3257A



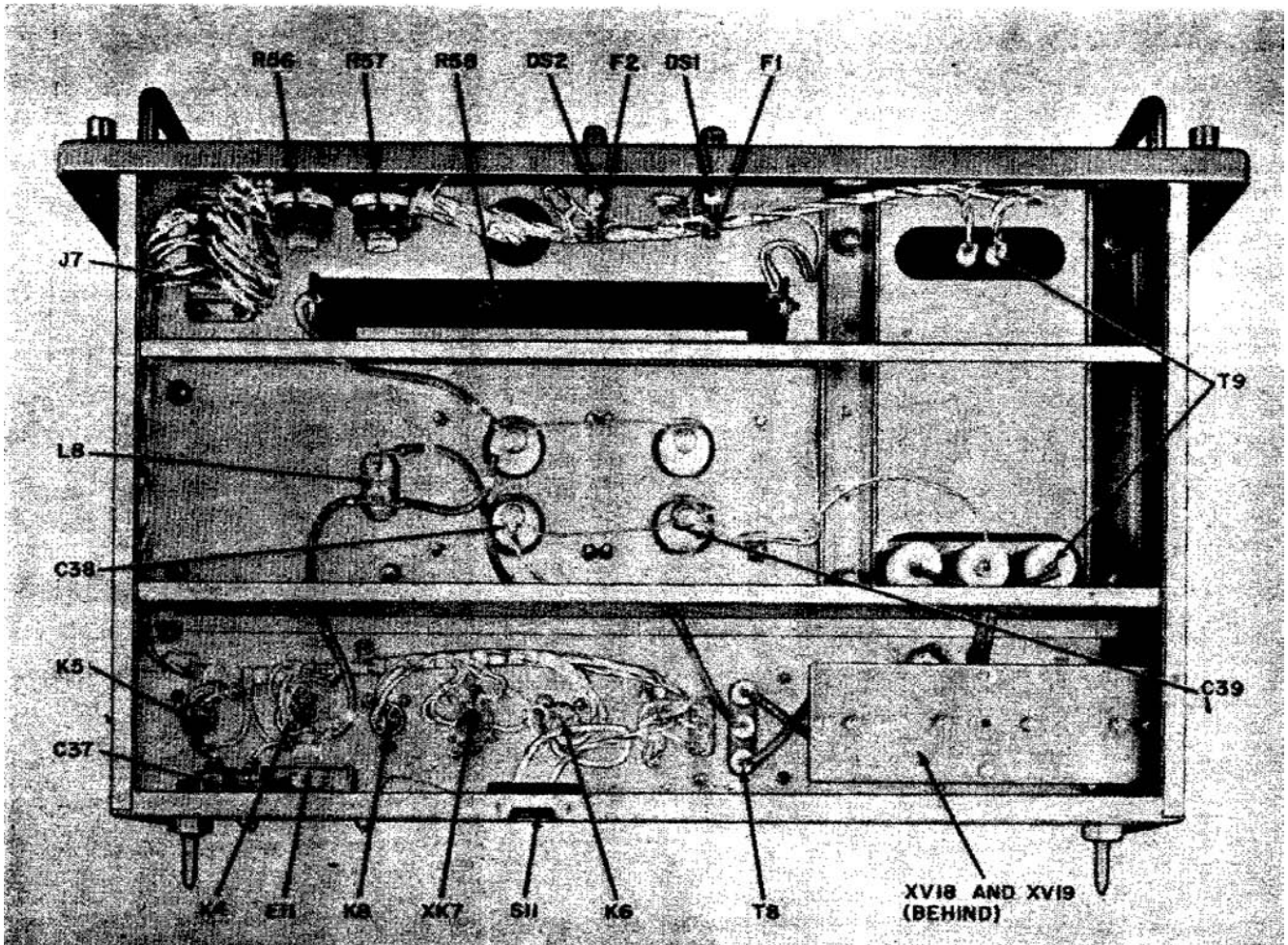

Figure 84.1. (Added) Power supply deck, bottom view, E model transmitters.

AGO 3257A

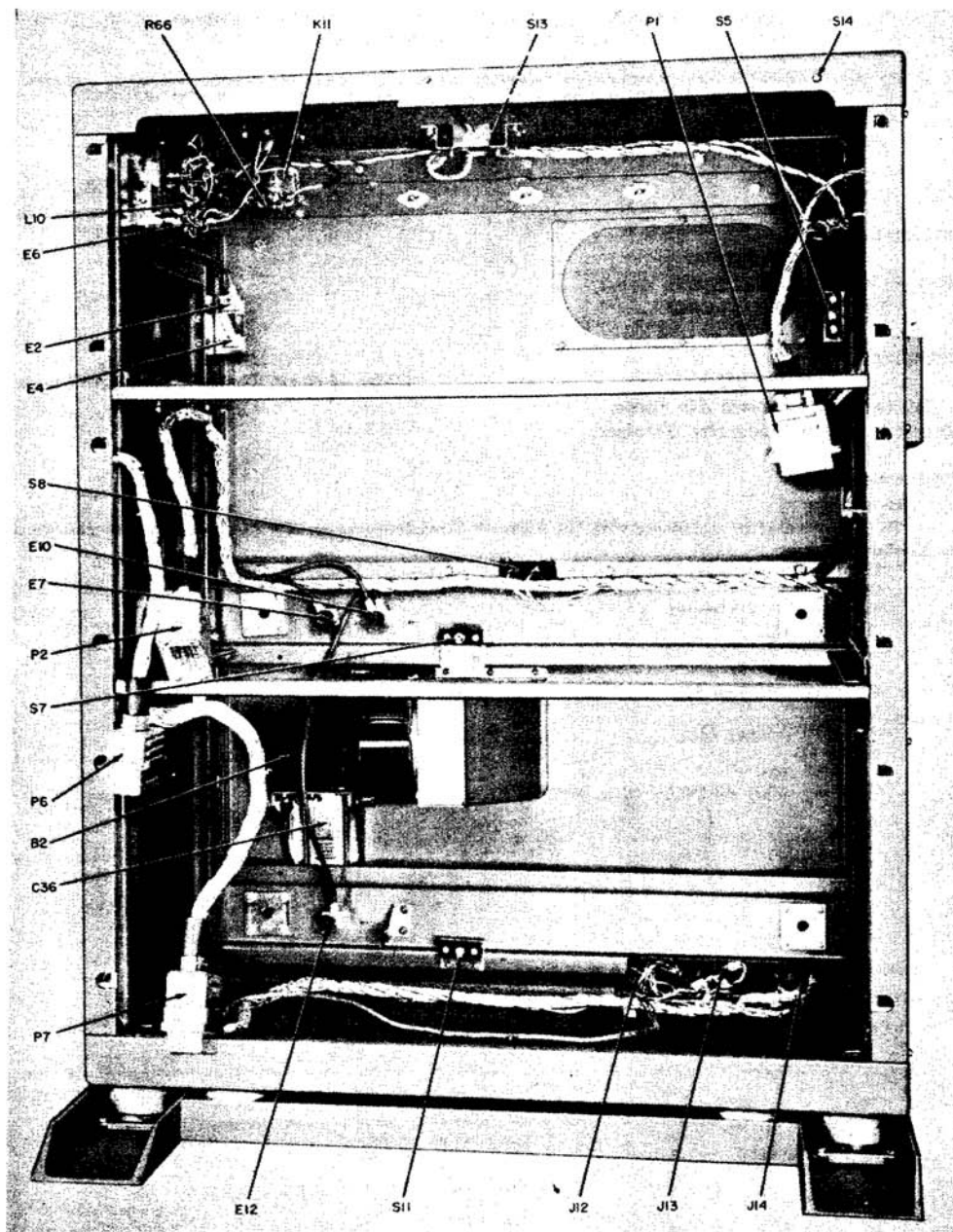

Figure 88.1.(Added) Transmitter housing decks removed, E model transmitters.

AGO 3257A

Figure 102. (Added) E model transmitters, rf deck, schematic diagram.

**(Located in back of these changes)**

Figure 103. (Added) E model transmitters, modulator deck, power deck, and housing, schematic diagram.

**(Located in back of these changes)**

BY ORDER OF THE SECRETARIES OF THE ARMY AND THE AIR FORCE:

OFFICIAL:

R. V. LEE,  
Major General, United States Army,  
The Adjutant General.

G. H. DECKER,  
General, United States Army,  
Chief of Staff.

OFFICIAL:

J. L TARR,  
Colonel, United States Air Force,  
Director of Administrative Services.

THOMAS D. WHITE,  
Chief of Staff, United States Air Force.

Distribution:

*Active Army:*

To be distributed in accordance with DA Form 12-7 requirements for TM 11-series ( Unclas) plus the following:

USASA (2)	11-38
CNGB (1)	11-39
Tech Stf, DA (1) except	11-55
CSigO (36)	11-57
Def Atomic Spt Agcy (5)	11-85
USARADCOM (2)	11-87
USARADCOM Rgn (2)	11-95
MDW (1)	11-98
Seventh US Army (2)	11-99
EUSA (2)	11-117
USASCS (88)	11-155
Units org under fol TOE: (2 ea UNOINDC)	11-237
11-5	11-500 AA-AE(4)
11-7	11-557
11-15	11-587
11-16	11-592
11-17	11-597
11-18	29-56
11-37	

NG: State AG (3); units same as Active Army except allowance is one copy to each unit.

USAR: None.

For explanation of abbreviations used, see AR 320-50.

AGO 3267A

**RADIO TRANSMITTERS T-368/URT, T-368A/URT, T-368B/URT,  
T-368C/URT, AND T-368D/URT; ANTENNA TUNING UNIT  
BC-939-B; RADIO FREQUENCY TUNER TN-339/GR; AND  
STANDING WAVE RATIO-POWER METER ME-165/G; FIELD  
AND DEPOT MAINTENANCE**

TM 11-809 -35  
TO 31R2-2URT-134  
CHANGES No. 1

}

DEPARTMENTS OF THE ARMY  
AND THE AIR FORCE  
WASHINGTON 25, D. C., 15 October 1959

TM 11-809-35/TO 31R2-2URT-134, 8 December 1958, is changed as indicated so that the manual also applies to Transmitter, Radio T-368D/URT, Tuner, Radio Frequency TN-339/ GR, and Standing Wave Ratio-Power Meter ME-165/G.

Change the title of the manual to: RADIO TRANSMITTERS T-368/URT, T-368A/URT, T-368B/URT, T-368C/URT, and T-368D/ URT; ANTENNA TUNING UNIT BC-939-B; RADIO FREQUENCY TUNER TN-339/GR; AND STANDING WAVE RATIO-POWER METER ME-165/G; FIELD AND DEPOT MAINTENANCE.

Add the following as note 4 to figure 33 (page 46) and note 1 to figures 34, 35, and 36 (page 47):

IN TUNER, RADIO FREQUENCY TN339/GR, L5 IS 6UH AND A CONNECTION IS ADDED BETWEEN THE TOP OF L5 AND THE MOVABLE TAP.

Add "and D model transmitters" after "28459-Phila-55" in the captions of the following figures:

Page 54, figure 41.

Page 71, figure 62.

Page 76, figure 67.

Page 2, chapter 1. Add the following "Note" below the title of chapter 1.

Note. Transmitter, Radio T-368D/URT is similar to Transmitter, Radio T-368C/URT. Reference to the C model applies to C and D models unless otherwise specified.

Paragraph 1a, line 3. After "BC-939-B," insert: It also covers field and depot, maintenance of Standing Wave Ratio Power Meter ME-165/G (matching

TAGO 2274A-Nov

unit) and Tuner, Radio Frequency TN-339/GR (antenna tuning unit).

Page 14 paragraph 8a, line 24. After "meter circuit," add: In D model transmitters on Order No. 39692-Phila-58, capacitor C50 is added at the clamper grid to maintain RF ground potential.

Page 15, paragraph 8c, line 4. After "T5," add: In D model transmitters, L3 is 70 uh nd 1-millihenry RF choke L13 is added in the line between M3 and the junction of C10 and L3. Figure 9. Add the following notes to the figure:

4. IN D MODEL TRANSMITTERS, C50, .01 UF, IS ADDED FROM PIN 3 OF V2 TO GROUND.
5. IN D MODEL TRANSMITTERS, L3 IS 70 UH AND L13, 1 MH, IS ADDED BETWEEN M3 AND THE JUNCTION OF L3 AND C10.

Page 18, paragraph 10a, line 9. After "R33," add: (In D model transmitters, the reference symbols of R33 and R35 are interchanged. )

Page 19, figure 13. Add the following note:

4. IN D MODEL TRANSMITTERS ON ORDER NO. 39692-PHILA-58, THE DESIGNATIONS OF R33 AND R35 ARE INTERCHANGED.

Page 32, paragraph 17b, line 11. After "I 4," add: (DS4 in D model transmitters).

Page 35, figure 27. Add the following notes to the figure:

4. IN D MODEL TRANSMITTERS, I 4 IS REFERENCED DS4.
5. IN D MODEL TRANSMITTERS, L3 IS 70 UH AND L13, 1 MH, IS ADDED BETWEEN M3 AND THE JUNCTION OF L3 AND C10.



Page 36, paragraph 18a. Make the following changes:  
 Line 4. After "I 3," insert: (DS3 in D model transmitters).  
 Line 7. After "I 2," insert: (DS2 in D model transmitters).  
 Line 24. After "I 1," insert: (DS1 in D model transmitters ).  
 Page 38, paragraph 18e, line 10. After "I 4", insert: (DS4 in D model transmitters).

Page 42, figure 30 (fold-out). Add the following note:  
 5. IN D MODEL TRANSMITTERS, I 1, I 2, I 3, AND I 4 ARE REFERENCED DS1, DS2, DS3, AND DS4, Respectively.  
 Page 46, figure 33, caption. After "BC-939-B," add: and Tuner, Radio Frequency TN-339/GR.  
 Page 47. Add section VI and figure 36.1 after Section V.

## Section VI. STANDING WAVE RATIO-POWER METER ME-165/G

### 23.1 . General (fig. 36.1)

The matching unit provides a noninductive dummy load of 52 ohms and, when connected between the transmitter and its load, permits direct readings of the transmitter power output and the standing wave ratio (SWR ) between the transmitter and its load.

### 23.2. Matching Unit Theory (fig. 36.1)

INPUT connector J1 and OUTPUT connector J2 provide for connection of rf cables from the transmitter and to the doublet antenna or to the antenna tuning unit. The transmitter is under load at all times. When the control switch is in the POWER, ADJUST, or SWR position, twelve 600-ohm resistors, R1 through R12, connected in parallel, are used as a dummy load. In the OPERATE position, the antenna loads the transmitter. The dummy load has an SWR of 1.1 to 1 or less at frequencies up to 30mc. Capacitors C9 and C10 provide balance, and bypass rf from the insulated resistor mounting plates to ground. Capacitor C8 is connected to the input line at all times to compensate for wiring inductance.

*a.* In the POWER position, power is applied through contacts 6 and 2 of S1 (A) to the dummy load and voltage divider R13 and R14. Adjustable capacitor C3, set at the factory, is connected across K13. Capacitor C3 adjusts meter linearity at higher frequencies. From the junction of C3 and R13, the circuit to the meter is completed through rf rectifier CRT, resistors R16, R17, and contacts 8 and 12 of S1 (B). Capacitor C4 works as

a filter capacitor with CR 1. Potentiometer R17 adjusts meter linearity at the lower frequencies. The lower scale of meter M1 indicates the rf power directly in watts. Capacitor C17 is an rf bypass capacitor.

*b.* In the ADJUST position, power is applied to the dummy load as in *a* above. It is also applied through contacts 12 and 9 of S1 (A) and through R15 to a bridge circuit consisting of R18, C5, R19, R20, R21, and CR2. From the junction of CR2 and C5, voltage is applied to filter R22 and C6 to ADJUST control R23. Potentiometer R23 controls voltage to M1 through contacts 9 and 12 of S1 (B). Potentiometer R23 allows meter M1 to be adjusted to full scale for SWR calibration purposes.

*c.* In the SWR position, power is applied to the dummy load and to R15 and the bridge circuit as in *b* above. In addition, however, one leg of the bridge circuit ( at the junction of R18 and C5) is connected directly to the OUTPUT jack and the normal transmitter load. The SWR ratio is read on the upper scale of the meter.

*d.* In the OPERATE position, a direct connection is made between INPUT connector J1 and OUTPUT connector J2 through contacts 6 and 5 of S1 (A).

Page 49, paragraph 26. Add the following at the end of the table:

Description	Fig. No.
Matching Unit: Interior view	95.1
Terminal board TB2	95.2

AGO 2274A

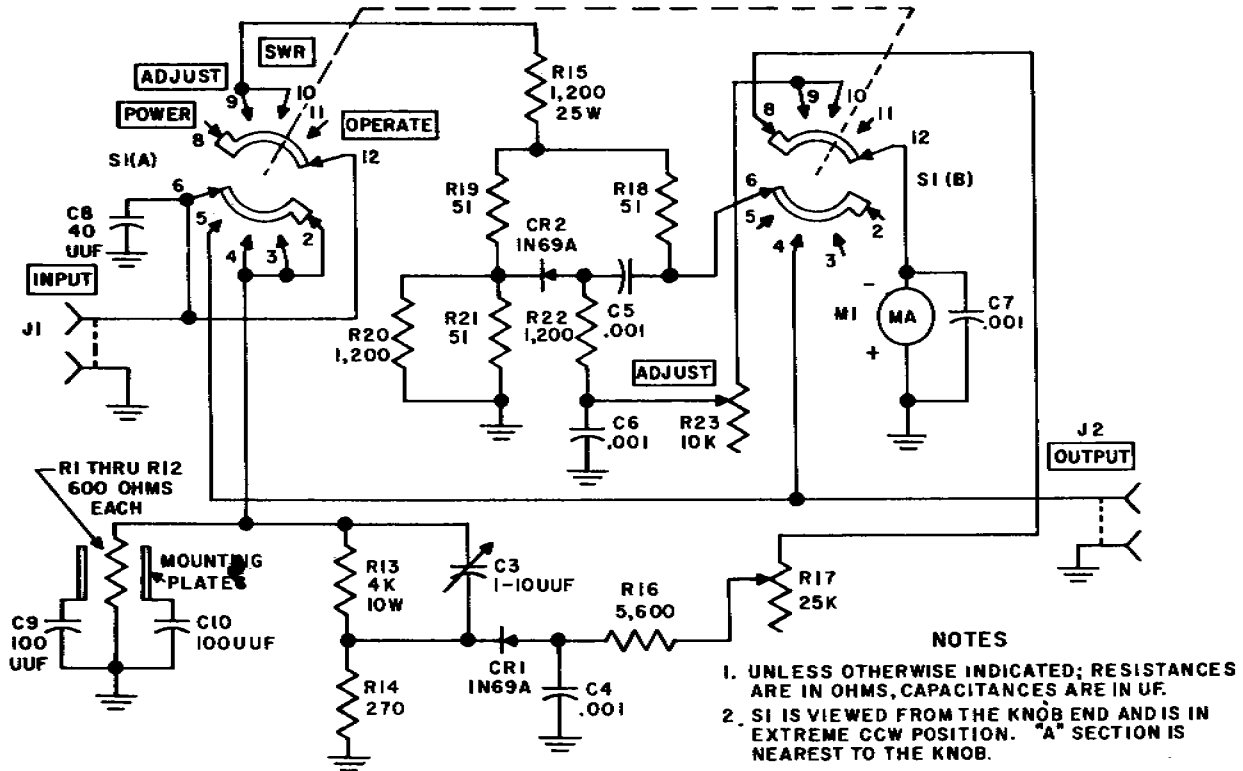

TM 809-35-C1-1

Figure 36.1. (Added) Standing wave ratio-power meter ME-165/G, schematic diagram.

Page 54, figure 41. Add the following note:

**NOTE**

IN D MODEL TRANSMITTERS ON ORDER NO. 39692-PHILA-58, L3 LOCATED BENEATH THE MOUNTING PLATE OF L4.

Page 85, paragraph 31, "Symptom" column,

last item, line 6. Change "TUNE-PANEL" to "TUNE-NORMAL." In "Correction" column, after "I 4," add: (DS4 in D model transmitters) .

Page 89, paragraph 31. Add paragraph 31.1 after paragraph 31.

**31.1. Troubleshooting Chart for Matching Unit**

Symptom	Probable cause	Correction
Transmitter on and control switch in POWER position. No meter indication.	Diode CR1 R13, R16, or R17 open. Defective contacts on S1. Shorted C4. Defective meter.	Check and replace.
Control switch in POWER position. Incorrect power indication at lower frequencies.	Resistor R17 incorrectly set.	Measure input power and reset R17 (par. 43.1).
Control switch in POWER position. Incorrect power indication at higher frequencies.	Capacitor C3 incorrectly set.	Measure input power and reset C3 (par. 43.1).
Control switch in ADJUST position. No meter indication.	Diode CR2, R15, R22, or R23 open. Defective contacts of S1.	Check and replace

Symptom	Probable trouble	Correction
Control switch in ADJUST position. Full-scale meter reading cannot be obtained by use of ADJUST control.	Insufficient power input	Increase transmitter power output; at least 150 watts is required.
Control switch in SWR position. Full-scale meter indication	No load connected to OUTPUT connector	Connect antenna and tuning unit.
Control switch in SWR position. Cannot get 1:1 ratio with a 52-ohm, ½-watt composition resistor as load	Resistor R18, R19, R20, or R21 open or more than 3% out of tolerance	Check and replace.

Page 109. Add paragraph 42.1 after paragraph 42.

**42.1. Servicing Standing Wave Ratio-Power Meter ME-165/G**  
(figs. 95.1 and 95.2) (Added)

The components of the matching unit can be reached easily for repair or replacement. The

front panel, on which all components are mounted, can be removed from the case by removing the 10 screws around the panel edge. If switch S1 is removed, be sure to tag the wires as they are unsoldered.

Page 109. Insert figures 95.1 and 95.2 after figure 95:

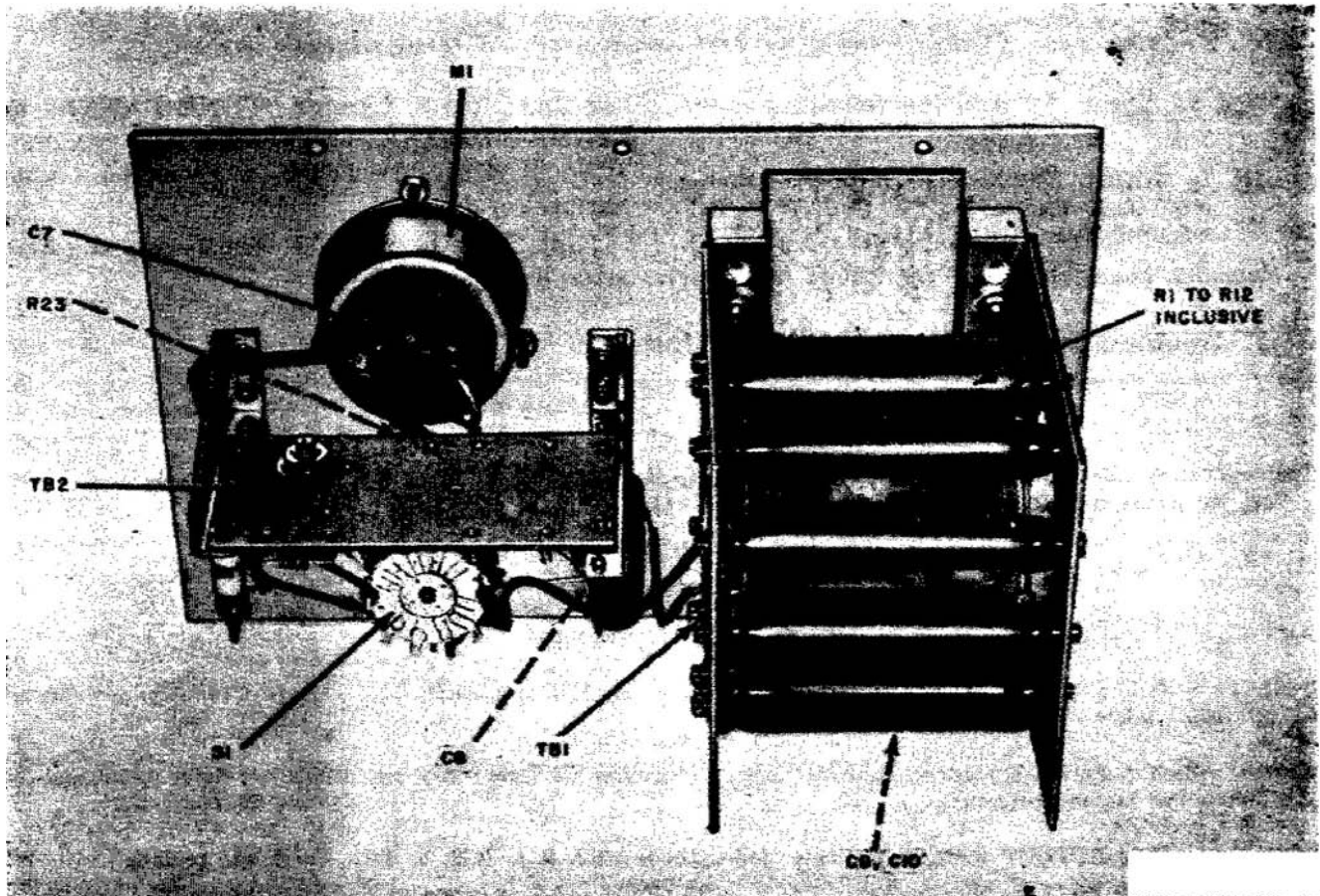
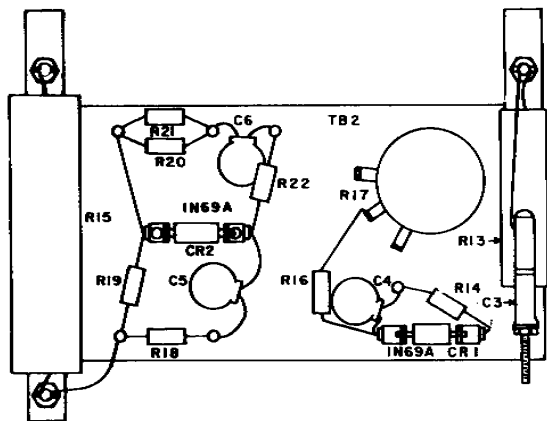

Figure 95.1. (Added) Standing wave ratio-power meter ME-165/G, interior view.



TM 809-35-C1-1

Figure 95.2 (Added) Terminal board TB2 of standing wave ratio-power meter ME-1 65/G. Page 110, paragraph 43. Add paragraph 43.1 after paragraph 43.

### 43.1. Calibration of Matching Unit Power Meter (Added)

Resistor R17 and capacitor C3 (fig. 95.2) can be used to adjust the accuracy of the matching unit meter in power measurements. Remove the front panel, on which all components are mounted, from the case.

a. Connect Wattmeter AN/URM-86 between the RF OUTPUT receptacle and the INPUT connector of the matching unit.

b. Set the equipment for cw operation (par. 18 and 19, TM 11-809-10) at some frequency between 1.5 and 2 mc. Set the matching unit control switch to the POWER position. Key the transmitter.

c. Compare the power readings on the watt. meter and on the matching unit meter. They should agree within 5 percent. If the power meter reading is not correct within 6 percent, adjust R17.

**Caution:** Be extremely careful when making this adjustments; dangerous RF voltages may be present.

d. Set the equipment for cw operation at approximately 19 mc, key the transmitter, and compare power meter readings on the wattmeter and on the matching unit meter. They should agree within 5 percent. If the power meter reading is not correct within 5 percent, adjust C3.

**Caution:** Be extremely careful when making this adjustment; dangerous RF voltages may be present.

e. Repeat the procedures given in b, c, and d above, as necessary, until the matching unit power meter readings are correct at both ends of the transmitter frequency range.

Page 111, paragraph 48b, line 2. Change "TM 11-809-20" to:

TM 11-809-10.

Page 114, figure 100 (fold-out). Make the following changes:

Note 2. After "LATE C," add: AND D.

Note 5. Add notes 6 and 7 after note 5.

6. IN D MODEL TRANSMITTERS, C50, .01 UF, IS CONNECTED FROM PIN 3 OF V2 TO GROUND.

7. IN D MODEL TRANSMITTERS, L3 IS 70 UH, AND L13, 1 MH, IS ADDED BETWEEN M3 AND THE JUNCTION OF L3 AND C10.

Page 114, figure 101 (fold-out). Make the following changes:

Notes 3 and 4. After "C MODEL," add: AND D MODEL.

Note 4. Add notes 5 and 6 after note 4.

5. IN D MODEL TRANSMITTERS, DESIGNATIONS OF R33 AND R35 ARE INTERCHANGED.

6. IN D MODEL TRANSMITTERS, I 1, I 2, I 3, AND I 4 ARE REFERENCED DS1, DS2, DS3, AND DS4, RESPECTIVELY.

[AG 413.44 (30 Sep 59)]

BY ORDER OF THE SECRETARIES OF THE ARMY AND THE AIR FORCE:

Official:

R. V. LEE,  
*Major General, United States Army,  
The Adjutant General.*

L. LEMNITZER,  
*General, United States Army,  
Chief of Staff*

Official:

J. L. TARR,  
*Colonel, United States Air Force,  
Director of Administrative Services.*

THOMAS D. WHITE,  
*Chief of Staff United States Air Force.*

Distribution:

Active Army:

USASA (2)  
Def Atomic Spt Agcy (5)  
CNGB (1)  
Tech Stf, DA (1) except  
    CSigO (18)  
Tech Stf Bd (1)  
USCONARC (5)  
USA Arty Bd (1)  
USA Armor Bd (1)  
USA Armor Bd Test Sec (1)  
USA Inf Bd (1)  
USA Air Def Bd (1)  
USA Air Def Bd Test Spc (1)  
USA Abn & Elct Bd (1)  
USA Avn Bd (1)  
USA Arctic Test Bd (1)  
US ARADCOM (2)  
US ARADCOM, Rgn (2)  
OS Maj Comd (5)  
OS Base Comd (5)  
Log Comd (5)  
USA Ord Msl Comd (3)  
MDW (1)  
Armies (5) except  
    First US Army (7)  
Corps (2)  
Div (2)  
USATC (2)  
Yuma Test Sta (2)  
Fort Belvoir (5)  
USA Elct PG (1)  
Svc Colleges (5)  
Br Svc Sch (5) except  
USASCS (25) except  
USASCS, Ft. Monmouth (700)  
GENDEP (2) except  
    Atlanta GENDEP (none)

Sig Sec. GENDEP (10)  
Sig Depots (17)  
AFIP (1)  
WRAMC (1)  
AMS (1)  
Engr Maint Cen (1)  
USA Comm Agcy (2)  
USA Sig Engr Agcy (1)  
USA Sig Pub Agcy (8)  
USA Sig Eqp Spt Agcy (2)  
USA Msl Spt Agcy (13)  
USA Pictorial Cen (2)  
Ports of Emb (OS) (2)  
Trans Terminal Comd (1)  
Army Terminals (1)  
OS Sup Agcy (1)  
Sig Fld Maint Shops (8)  
Sig Lab (5)  
USASSA (15)  
Mid-Western Rgn Ofc (USASSA) (1)  
Mil Dist (1)  
Sectors, USA Corps (Res) (13)  
USA Corps (Res) (1)  
JBUSMC (2)  
Mil Msn (2)  
Units org under fol TOE:  
    11-5 (2)           11-87 (2)  
    11-7 (2)           11-95 (2)  
    11-15 (2)          11-98 (2)  
    11-16 (2)          11-99 (2)  
    11-17 (2)          11-117 (2)  
    11-18 (2)          11-155 (2)  
    11-37 (2)          11-500 (AA-AE) (2)  
    11-39 (2)          11-557 (2)  
    11-55 (2)          11-587 (2)  
    11-67 (2)          11-592 (2)  
    11-85 (2)          11-597 (2)

NG: State AG (3); units-same as Active Army except allowance is one copy to each unit.

USAR: None.

For explanation of abbreviations used, see AR 320-50 .

AGO 2274A

TECHNICAL MANUAL  
NO. 11-809- 35  
TECHNICAL ORDER  
NO. 31R2-2URT-134

DEPARTMENTS OF THE ARMY  
AND THE AIR FORCE

WASHINGTON 25, D. C., 8 December 1958

**RADIO TRANSMITTERS T-368/URT, T-368A/URT, T-368B/URT, AND  
T-368C/URT, AND ANTENNA TUNING UNIT BC-939-B**

		Paragraphs Page	
Chapter 1.	THEORY		
Section I.	Introduction and block diagram .....	1, 2	2
II.	Transmitter stages .....	3-17	4
III.	Control and protection circuits .....	18,19	36
IV.	Mechanical analysis of transmitter .....	20, 21	44
V.	Antenna tuning unit .....	22, 23	46
Chapter 2.	TROUBLESHOOTING.....	24-35	48
3.	REPAIRS, ALINEMENT, AND FINAL TESTING		
Section I.	Repairs.....	36-42	101
II.	Alinement procedures and final testing .....	43-56	109
INDEX.....			116

---

\*TM 11-809-35, together with TM 11-809-10 and TM 11-809-20, supersedes TM 11-809, 22 April 1955, including C 1, 11 December 1956, C 2, 24 January 1957, C 3, 4 April 1957 and C 4, 8 May 1957.

# CHAPTER 1

## THEORY

---

### Section I. INTRODUCTION AND BLOCK DIAGRAM

#### 1. Scope

*a.* This manual covers field and depot maintenance for Radio Transmitter T-368 ( \* ) /URT and Antenna Tuning Unit BC-939-B. It includes instructions appropriate to third, fourth, and fifth echelons for troubleshooting, testing, alining, and repairing the equipment, replacing maintenance parts, and repairing specific maintenance parts. It also lists tools, materials, and test equipment for third, fourth, and fifth echelon maintenance parts. It also lists tools, materials, and test equipment for third, fourth, and fifth echelon maintenance. Detailed functions of the components are covered in this theory chapter.

*b.* Complete instructions for this equipment include eight other publications:

TM 11-809-10, Radio Transmitters T-368/URT, T-368A/URT, T-368B/URT, and T-368C/URT and Antenna Tuning Unit BC-939-B, Operator's Manual.

TM 11-809-20, Radio Transmitters T-368/URT, T-368A/URT, T-368B/URT and T-368B/URT and Antenna Tuning Unit BC-939-B, Organizational Maintenance.

TM 11-5820-258-10P, Operator's Maintenance Repair Parts and Special Tools List for Radio Transmitters T-368/URT, T-368A/URT, T-368B/URT and T-368C/URT.

TM 11-5820-258-20P, Organizational Maintenance Repair Parts and Special Tools List for Radio Transmitters T-368/URT, T-368A/URT, T-368B/URT, and T-368C/URT.

TM11-5820-258-35P, Field and Depot Maintenance Repair Parts and Special Tools List for Radio Transmitters T-368/URT, T-368A/URT, T-368B/URT, and T-368C/URT.

TM 11-5820-257-10P, Operator's Maintenance Repair Parts and Special Tools List for Antenna Tuning Units BC-939A and BC-939-B.

TM 11-5820-257-20P, Organizational Maintenance Repair Parts and Special Tools List for Antenna Tuning Units BC-939-A and BC-939-B.

TM 11-5820-257-35P, Field and Depot Maintenance Repair Parts and Special Tools List for Antenna Tuning Units BC-939-A and BC-939-B.

*c.* Forward comments concerning this manual to the Commanding Officer, United States Army Signal Publications Agency, Fort Monmouth, N. J.

*d.* For applicable forms and records, see paragraph 2, TM 11-809-10.

#### 2. Block Diagram

(figs. 1 and 2)

Radio Transmitter T-368(\*)/URT is basically a continuous-wave (CW) and amplitude modulated (AM) transmitter that contains its own power supplies. The equipment requires a handkey, a microphone, an alternating-current (ac) source, and an antenna to provide CW and am communications in the frequency range of 1.5 to 20.0 megacycles (mc). Provisions are made in the equipment to act as a power amplifier to increase the distance range of low powered external exciter units. The input signals are not restricted to the CW type radio frequency (RF) signals. The transmitter will accept frequency-shift and also narrow-band frequency-modulated (FM) signals. Provision also is made in the audio-frequency (AF) section for the equipment to accept signals fed over a 600-ohm line from a telephone set. Another provision permits a receiver to use the same

AGO 2742A

transmitting antenna through the use of an antenna changeover relay. The functions of the RF, AF, and power supply stages are described briefly in *a* through *b* below and described in detail in paragraphs 3 through 17.

*a.* The master oscillator (mo) and first buffer amplifier use two type 5749 tubes, V801 and V802, in circuits which, in the basic and A models, are operative for CW or AM operation only. In the B and C models, these stages are operative in all modes of operation except EXT EXC. Oscillator tuning is ganged with the multiplier stages so that the entire frequency range of 1.5 to 20.0 mc can be covered in four bands by a single control. The output of V801 is fed through a capacitor to the grid of first buffer tube V802. First buffer V802 is an untuned amplifier used to isolate load effects of the succeeding stages on the mo to prevent oscillator drift. In the basic model (fig. 1), the output of V802 is fed to the grid of second buffer and first multiplier tube V101 by a coaxial cable. In the lettered models, by internal recabling (fig. 5, TM 11-809-20) the output of V802 can be applied to Radio Modulator MD-239/GR. This change in signal paths is indicated by the dotted lines in figure 2.

*b.* The multiplier subassembly contains three 6AH6 tubes in the multiplier strip and one type 6000 tube in the intermediate power amplifier (ipa) stage. The multiplier strip consists of a second buffer-first multiplier V101, second multiplier V102, and third multiplier V103. The ipa stage, V104, contains four output tank circuits that cover the entire frequency range of the transmitter. The output of V104 is fed to the grid of power amplifier (pa) tube V1 by coaxial cable. For operation in the four bands, the 2 tables below show the tubes that function to meet the frequency requirements.

(1) Tubes used for CW and AM operation of the basic and A models and for CW, AM, FSK, and FSK-AM operation of the B and C models are as follows:

Hand ( mc )	Tube used	Function
1.5-3.0	V801	Master oscillator.
	V802	First buffer.
	V101	Second buffer.
	V104	Amplifier

Band ( mc )	Tube used	Function
3.0-6.0	V801 and V802 V101 V104	Master oscillator and first buffer. First multiplier. Amplifier.
6.0-12.0	V801 and V802. V101 V102 V104	Master oscillator and first buffer. First multiplier. Second multiplier. Amplifier.
12.0-20.0	V801 and V802. V101 V102 V103 V104	Master oscillator and first buffer. First multiplier. Second multiplier. Third multiplier. Amplifier.

(2) Tubes used for FSK and FSK-AM operation in the basic and A models are as follows:

Fsk exciter output Frequency between 1.5 and 3.0 mc		
Hand mc	Tubes used	Function
1.5-3.0	V101 V104	Buffer. Amplifier.
3.0-6.0	V101 V104	First multiplier. Amplifier.
6.0-12.0	V101 V102 V104	First multiplier. Second multiplier. Amplifier.

Fsk exciter output frequency between 3.0 and 6.0 mc		
Band ( mc )	Tubes used	Function
3.0-6.0	V101 V104	Amplifier. Amplifier.
6.0-12.0	V101 V102 V104	Amplifier. Multiplier Amplifier.
12.0-20.0	V101 V102 V103 V104	Amplifier. Multiplier. Multiplier. Amplifier.

(3) Tubes used for EXT EXC operation are as follows:

Band ( mc )	Tubes used	Function
1.5-3.0	V104 for all bands.	Amplifier for all bands
3.0-6.0		
6.0-12.0		
12.0-20.0		



c. Intermediate power amplifier V104 uses tube type 6000. In lettered models, ipa stage is protected from drawing excessive current, when signal excitation is removed, by a protective clamping circuit. The clamping circuit consists of protective relay K10 and protective relay control tube V23 (fig. 8).

d. The pa stage uses type 4-400A tube VI in a circuit that is tuned separately from the ganged tuning exciter circuits. A clamping circuit, that uses type 5933 tube V2, protects the pa tube from drawing excessive current, if excitation, which develops pa bias, is lost. The output of V1 is applied to the antenna through tuned pi-network and loading coil circuits. Individual tuning controls, POWER AMPLIFIER TUNING and POWER AMPLIFIER LOADING, adjust the pa stage for proper operation. An antenna changeover relay is used so that a receiver may use the transmitter antenna during inoperative periods of the transmitter.

e. For AM or FSK-AM operation, the power amplifier is plate-modulated by push-pull type 4D21 modulator tubes V9 and V10. The modulators are driven by a four-stage speech amplifier, which receives an input from either a carbon microphone or a 600-ohm

telephone line. The first section of the speech amplifier consists of first and second AF amplifiers V12A and V12B which are preamplifiers for the 600-ohm line and the carbon microphone inputs, respectively. The next section contains high-pass filter FL1 and third amplifier V13A. A speech clipper stage is added to maintain a relatively constant AF output level for fluctuating voice input levels. A low-pass filter follows the clipper and serves as input to fourth AF amplifier V13B. The final stage is AF driver V15 which provides the proper AF level to drive the modulator tubes. The speech amplifier also contains sidetone oscillator V17 and cathode follower V16 to allow the operator to monitor keying during CW operation.

f. The equipment furnishes all the direct current (dc) voltages required for the five types of operation from two low-voltage supplies and one high-voltage supply when 115 volts are available. One low-voltage supply is the exciter supply and the other is the bias supply. The high voltage supply uses two type 3B28 tubes, V18 and V19. Figures 1 and 2 list the stages operated from each power supply.

## Section II. TRANSMITTER STAGES

### 3. Master Oscillator and First Buffer Stages (fig. 3)

a. Master oscillator V801 is an electron coupled Hartley oscillator tunable from 1.5 to 3.0 mc. Oscillations are produced by coupling RF on the screen grid back to the cathode through bypass capacitor C806 and the tickler portion of coil L801. The voltage feedback to the control grid through capacitor C805 is of sufficient amplitude to overcome the circuit losses and sustain oscillations. During oscillation, the control grid draws current to charge C805 and consequently grid leak bias is developed across grid resistor R801. The mo is tuned by the tank and circuit that consists of capacitors C801 through C804 and slug-tuned inductors L801 and L803. The slug in L801 is gear-driven from the panel-mounted tuning control which also drives the tuning slugs in the multiplier strip. Resistor R802 is the screen grid dropping resistor. The signal from the oscillator is coupled to the plate of V801 by the electron stream. The amplified

output signal across plate load resistor R803 is coupled through capacitor C807 to the grid of first buffer V802.

b. First buffer V802 is an untuned resistance capacitance coupled amplifier. Resistor R804 is the grid leak resistor, R805 is the screen dropping resistor, and C808 is the screen RF bypass capacitor. The output developed across plate load resistor R806 is coupled through capacitor C809 and fed to the multiplier strip or an external excitation input (fig. 2) through a coaxial cable.

c. The plate and screen of both V801 and V802 are supplied regulated +150 volts through the AM or CW position of SERVICE SELECTOR switch S1 in the basic and A models (all positions except EXT EXC in the B and C models). Capacitors C810 and C152 and choke L802 form a decoupling network to prevent RF from entering the supply. Heater HR801, thermostat S801, and capacitor C811 (fig. 97) are

supplied as part of the oscillator subassembly, but are not used in this transmitter.

#### 4. Second Buffer and First Multiplier Stage (fig. 4)

Second buffer and first multiplier tube V101 receives an rf input from either first buffer tube V802 or from an external frequency-shift keying (fsk) exciter. The stage functions as a straight-through buffer amplifier, or as a frequency doubler, depending on the band used.

a. In the basic model at all times, or in the lettered models when connected for general utility operation, the output of first buffer V802 is received at receptacle J101 through coupling capacitor C809, coaxial cable, and connector P801. In the basic and A models, this output

is available only in CW or AM operation. In the B and C models, it is available in all modes of operation except EXT EXC. The buffer output is impressed across a high impedance grid load network consisting of RF choke L101 and resistor R101 in series. Resistor R103 (in series with C101 and C102) is effectively in parallel to the RF choke (with R101) and broadens the stage response. When cabled for use with Radio Modulator MD-239/GR (fig. 5, TM 11-809-20), the fsk output is brought to the grid, pin 1, of V101 from FSK jack J16 by coaxial cable to J101. When cabled for general use, the output of the fsk exciter is connected to V101 from FSK jack J16 by coaxial cable through connector

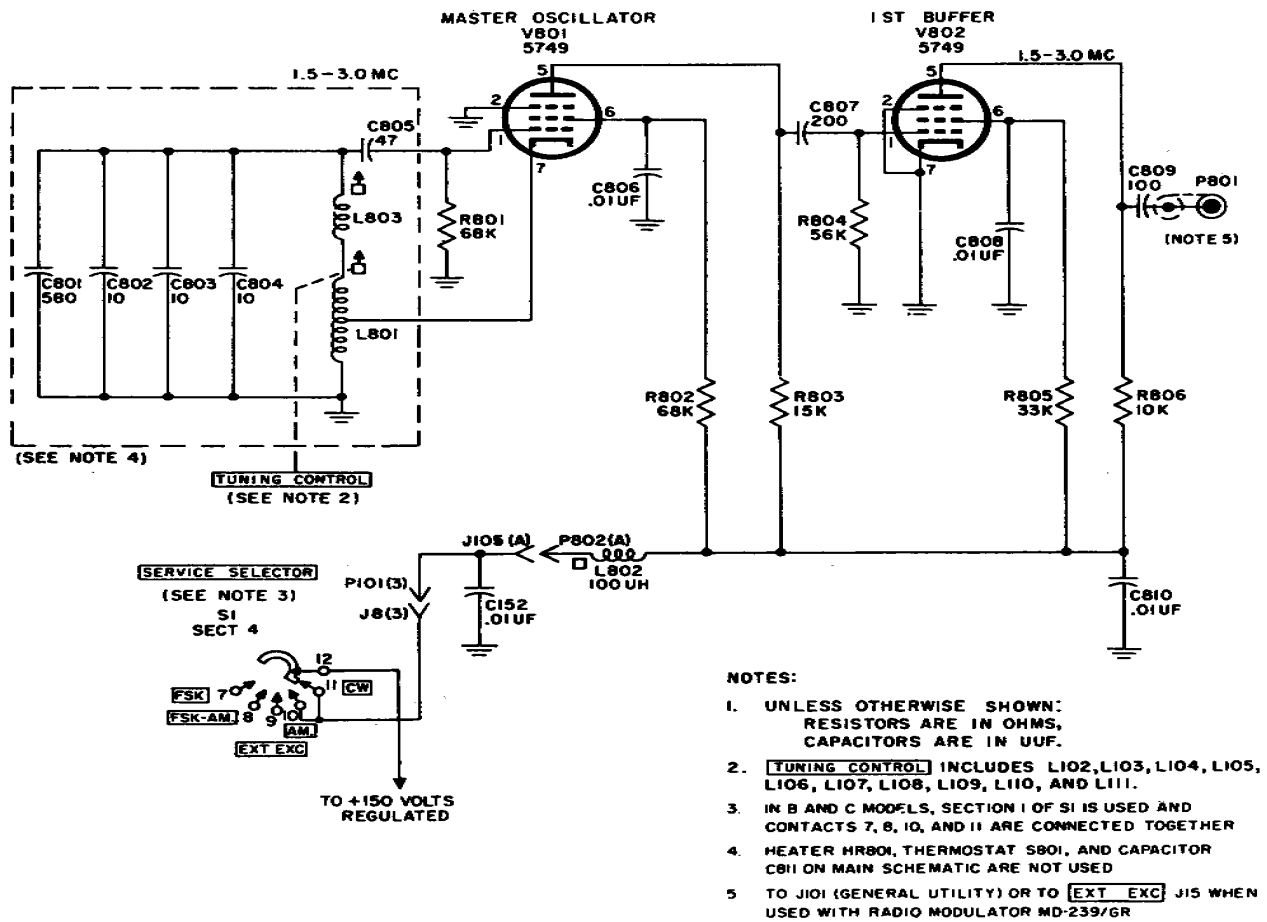

Figure 3. Master oscillator and first buffer stages.

TM 809-35-3

P10 and receptacle J102. The cable is terminated by a 56-ohm impedance (R101). For input frequencies between 1.5 and 3.0 mc, V101 acts as a buffer amplifier stage, and when the BAND SELECTOR switch is turned to the 3.0-6.0 mc range, V101 acts as a multiplier stage. When the input is in the range of 3.0 to 6.0 mc (fsk exciter source only), V101 acts as a straight-through amplifier, and the BAND SELECTOR switch is set at the 3.0-6.0 mc position.

*b.* In CW or AM operation, V101 is blocked-grid keyed. Blocking bias is applied to the control grid of V101 through resistors R110, R102, and R103. Resistor R102 and capacitor C102 decouple the RF input from the bias supply. When the handkey or the push-to-talk switch on the microphone is closed, the blocking bias is removed from the grid of V101 by grounding the grid circuit at the junction of R102 and R110. In the basic model (fig. 4), the handkey and push-to-talk switch energize relay K2. In the lettered models, they ground the line directly. The stage then becomes operative. To improve keying characteristics, intermediate amplifier V104 is similarly blocked-grid keyed. For EXT EXC, FSK, or FSK-AM operations, which require that the FSK carrier be uninterrupted, the blocking bias is permanently removed by setting KEYING switch S6 of the lettered models to the CONTINUOUS position. In the basic model, the EXCITER PLATE POWER switch in the ON (up) position serves the same purpose.

*c.* RF excitation is applied to the control grid of V101 through capacitor C101. Cathode resistor R104, shunted by capacitor C103, provides normal operating bias when removal of the blocking bias permits the tube to conduct. The screen grid, bypassed for RF by capacitor C104, is supplied with operating potential through dropping resistor R105. Capacitors C105 and C106, with resistor R107, decouple the screen and plate circuits to prevent RF from entering the 275-volt power source.

*d.* The amplified output of V101 is developed across load resistor R106 or tank circuit Z101, depending on the position of BAND SELECTOR switch S101, section 4 rear. In the 1.5-3.0 position of the BAND SELECTOR switch oscillator or fsk exciter appears across R106, the amplified fundamental frequency of the master and is coupled through capacitor C107 and

section 2 rear of S101 directly to the grid circuit of ipa V104. Operation in the other bands, however, requires one or more stages of frequency multiplication. In the 3.0-6.0, 6.0-12.0, and 12.0-20.0 positions of S101, section 4 rear inserts tank circuit Z101 in place of R106 as the V101 plate load. Tank circuit Z101 is tuned to the second harmonic of the original excitation frequency by variable inductor L102 which is connected to the tuning mechanism, fixed capacitor C110, and trimmer C109. The 2.0- to 6.0-mc oscillations developed across Z101 are coupled through capacitor C108 to tank circuit Z102. Tank circuit Z102 is tuned from 3.0 to 6.0 mc by variable inductor L103 which is connected to the tuning mechanism, fixed capacitor C111, trimmer C112, and the input capacitance of the stage to which Z102 is connected. In the 3.0-6.0 position of the BAND SELECTOR, Z102 tunes the grid circuit of ipa V104 through section 4 front (contact 2) and section 2 rear (contact 3). In the 6.0-12.0 or 12.0-20.0 position of the BAND SELECTOR, Z102 tunes the grid circuit of second multiplier V102 through section 4 front (contact 4 or 6), further frequency multiplication being required for operation in either of these bands. Capacitor C113 provides a ground return for the RF excitation coupled into Z102.

*e.* Section 3, front of S101, grounds the control grids of both second multiplier V102 and third multiplier V103 when the BAND SELECTOR is in either the 1.5- or 3.0-6.0 position. This ground prevents these stages from being excited through stray wiring capacities, which would result in spurious oscillations in the output of the multiplier strip. In the 6.0-12.0 position of the BAND SELECTOR, the ground connection is removed from the grid of second multiplier V102 to permit the additional required multiplication, but is maintained at the grid of V103. The grid of V103 is ungrounded only when the BAND SELECTOR is in the 12.0-20.0 position.

## 5. Second Multiplier Stage (fig. 5)

*a.* Second multiplier tube V102 doubles the frequency of the signal generated in tank circuit

AGO 2742A

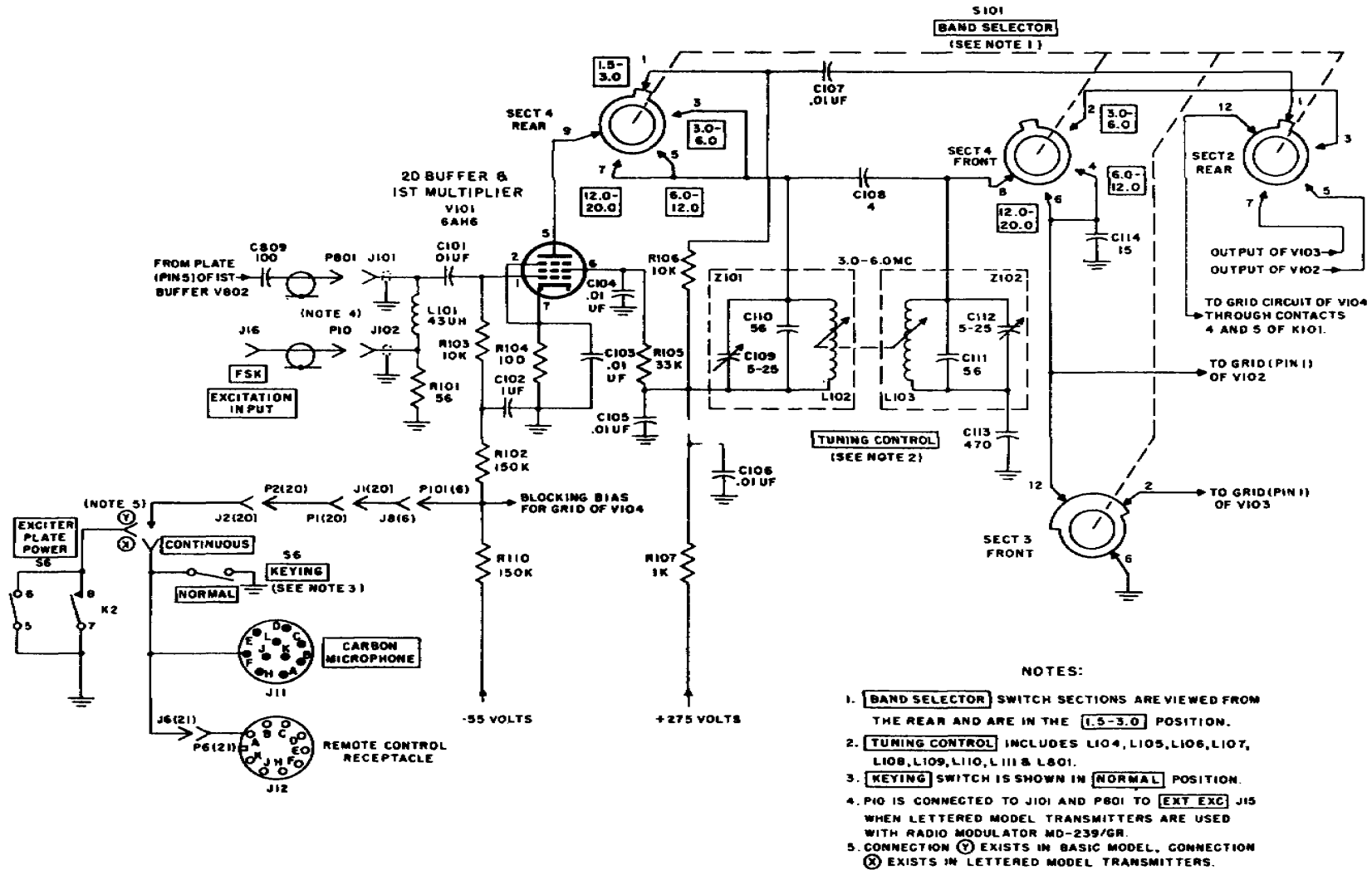

Figure 4. Second buffer and first multiplier stage.

TM 809-35-4

Z102, when section 4 front of the BAND SELECTOR switch is in either the 6.0-12.0 or 12.0-20.0 position. Operation in either of these bands therefore requires that Z102 tune with the input capacitance of V102, a type 6AH6 tube. In the 3.0-6.0 position of the BAND SELECTOR, however, Z102 tunes with the input capacitance of ipa V104. The input capacitance of V104, a type 6000 tube, is greater than the input capacitance of V102; therefore, capacitor C114 is added to the grid circuit of V102 to equalize the shunting effect across Z102 and to permit proper tracking on the high bands. With the BAND SELECTOR in either the 6.0-12.0 or 12.0-20.0 position, the control grid of V102 is not grounded by section 3 front. Resistor R108 provides a dc return as well as developing grid leak bias. The plate load consists of tank circuit Z103, which is tuned by variable inductor L104 connected to the tuning mechanism, fixed capacitor C119, and trimmer C118 to the second harmonic of the 3.0- to 6.0-mc input frequency. The 6.0- to 12.0-mc oscillations developed in Z103 are capacity-coupled by C121 to tank circuit Z104. Tank circuit Z104, consisting of variable inductor L105 connected to the tuning mechanism, fixed capacitor C122, and trimmer C123, tunes the grid circuit of either ipa V104 or third multiplier V103, depending on the setting of the BAND SELECTOR switch. In the 6.0-12.0 position of the BAND SELECTOR, Z104 is connected to the grid circuit of V104 through sections 3 and 2 rear. In the 12.0-20.0 position, Z104 is connected to the grid circuit of V103 through section 3 rear (contact 7). Capacitor C124 provides an RF ground return for the signal developed in Z104.

*b.* Other V102 circuit elements include cathode bias resistor R109 and bypass capacitor C116, screen RF bypass capacitor C117 and dropping resistor R111, and decoupling network R112 and C120.

## 6. Third Multiplier Stage

(fig. 6)

- a.* Third multiplier tube V103 receives the 6.0 to 12.0-mc output of second multiplier V102 and doubles it for operation in the 12.0- to 20.0mc band. Tank circuit Z104 is coupled to the grid of V103 through the 12.0-20.0 position of BAND SELECTOR switch section 3 rear; the

*b.* corresponding position of section 3 front ungrounds this grid to make the stage operable. Capacitor C125 equalizes the input capacitance of V103 with the input capacitance of ipa V104, to which Z104 is connected when section 3 rear is in the 6.0-12.0 position. The input signal that appears across grid resistor R113 is doubled in frequency by tuning plate tank circuit Z105 to the second harmonic of the input. Tank circuit Z105 is tuned by variable inductor L106, which is connected to the tuning mechanism and trimmer C128. The 12.0 to 20.0-mc signal developed across Z105 is coupled through capacitor C130 to tank circuit Z106, which tunes the grid circuit of ipa V104 through the 12.0-20.0 position of section 2 rear. Tank circuit Z106 is tuned by variable inductor L107, which is connected to the tuning mechanism and trimmer C131. Capacitor C132 is an RF ground return.

*b.* Circuit elements of the third multiplier include cathode bias resistor R114 and bypass capacitor C126, screen bypass capacitor C127 and screen dropping resistor R115, and plate and screen decoupling network C129 and R116.

## 7. Intermediate Power Amplifier Stage

(figs. 7 and 8)

Intermediate power amplifier V104 increases the power level of the RF excitation to the level required for driving the power amplifier.

*a.* For FSK, FSK-AM, AM, or CW operation, the output of the multiplier (from V101, V102, or V103) is tapped from the selected position of BAND SELECTOR switch section 2 rear and is applied to the grid of V104 through normally closed contacts 4 and 5 of K101 and parasitic suppressor R117. The cathode of V104 is returned directly to ground through contacts 2 and 1 of K101. Blocking bias is applied to the grid of V104 through resistors R119 and R118, with R119 and capacitor C133 forming an RF decoupling network. When the blocking bias is removed from V104, the input excitation causes grid current flow which develops operating grid leak bias across R118 and R119. The grid leak bias, and therefore the input excitation, is required to prevent excessive plate current flow which might otherwise damage the tube. If, however, excitation to the grid of tube V104 is lost while the blocked-grid voltage is removed

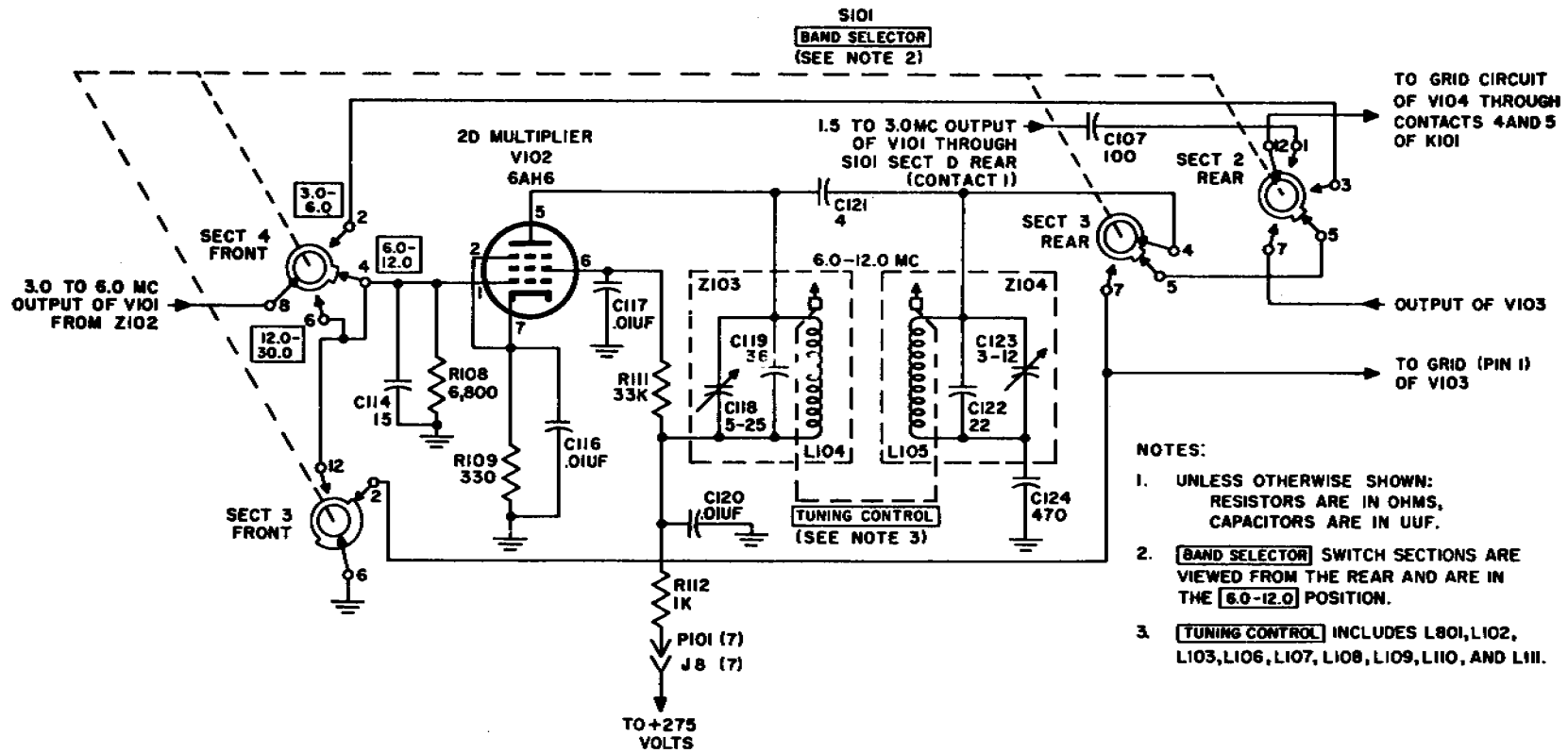

Figure 5. Second multiplier stage.

TM 809-21

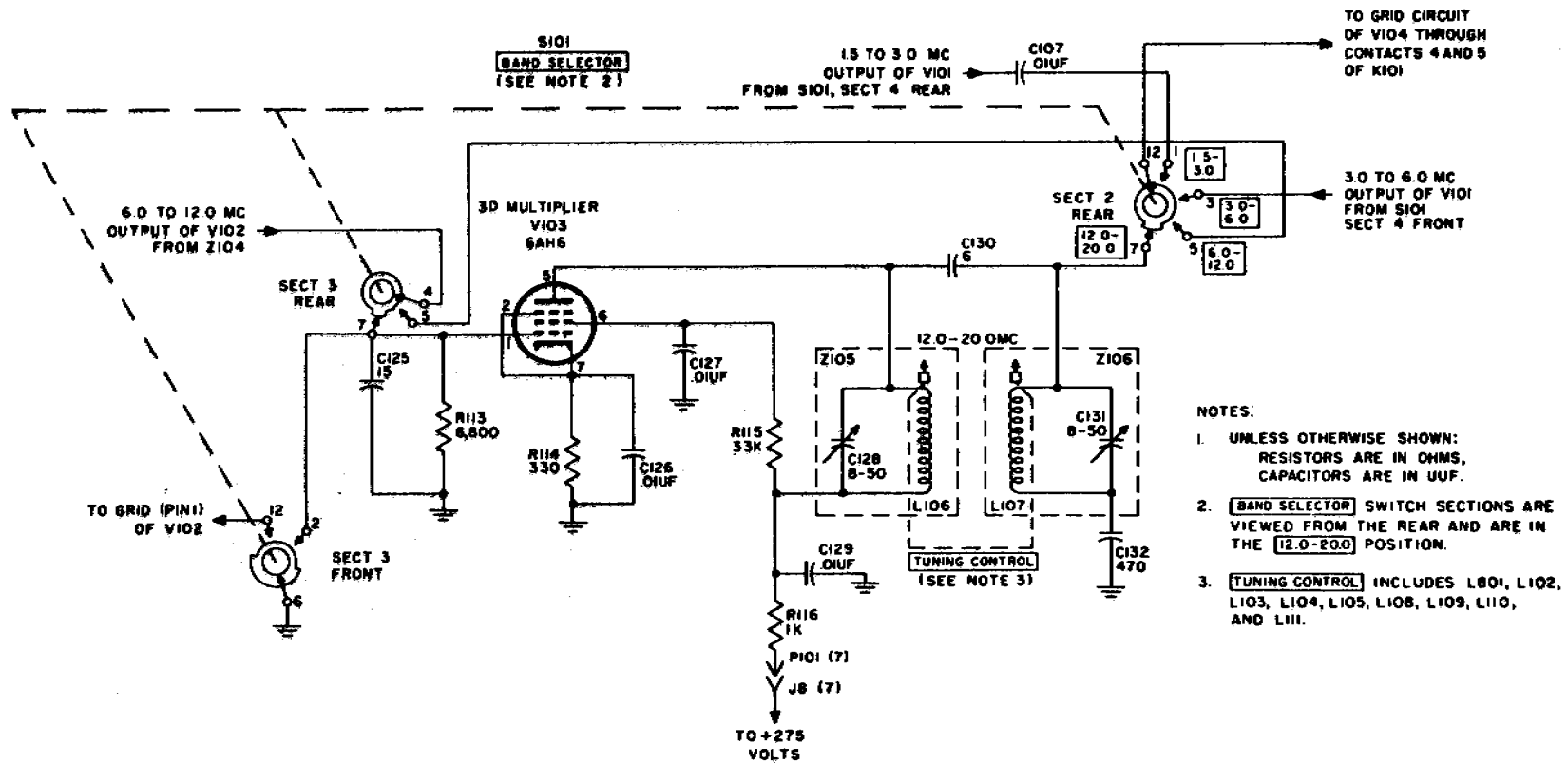

Figure 6. Third multiplier stage.

TM 809-22

(as would be the case if switch S6, a handkey, or a push-to-talk switch were closed), plate current of V104 could rise to a dangerous value, and damage the tube. In lettered model transmitters, this possibility is protected against by protective relay control tube V23 and relay K10 (fig. 8) which function to reduce the screen voltage of V104. Control voltage for this circuit is obtained from the junction of resistors R117 and R118 in the grid circuit of V104 and is applied to the control grid of V23 through decoupling resistor R122 (R138 in the A model transmitter). This voltage varies from -55 volts (with the blocked-grid voltage applied to V101 and V104) to 3 volts (with the blocked-grid voltage removed) and depends on the amount of excitation applied to the control grid of V104. At -55 volts, V23 remains cut off (nonconducting) and the full screen voltage is applied from the +275-volt source through normally closed contacts 5 and 6 of relay K10 and screen dropping resistor R120, allowing V104 to function normally. If loss of excitation to the grid of V104 occurs with the blocked-grid voltage removed, zero voltage will appear at the control grid of V104 and at the control grid of V23, allowing the protective relay control tube to conduct. Current flow in the plate circuit of V23 and the series coil of relay K10 causes contacts 5 and 6 of the relay to open, and resistor R75 is inserted in series with the +275-volt line to screen dropping resistor R120. This reduces the screen voltage by approximately 50 per cent and limits V104 plate current to a maximum safe value of .060 ampere. Because cathode bias protects V104 in EXT EXC operation, this protective system is not necessary, and the cathode circuit of V23 is not completed. In all other modes of operation, the cathode of protective relay control tube V23 is grounded through section 4, contacts 1, 2, 4, and 5, of SERVICE SELECTOR switch S1. In the A model, the cathode of V23 is grounded through section 1, contacts 7, 8, 10, and 11. In late C model transmitters, capacitor C49 is connected between the grid and cathode of V23. This bypasses any stray RF which may be picked up in the V23 cathode line because of lead dress and length. The time constant circuit of isolating resistor R122 and capacitor C156 (R138 and C163 in the A model) prevents relay K10 from following CW keying pulses.

They also form a decoupling circuit for the RF signal at V104.

*b.* The plate load of V104 consists of one of four tank circuits (fig. 7), as selected by section 1 rear of the BAND SELECTOR switch. In the 1.5-3.0 position of the BAND SELECTOR, the tank circuit used is Z107 (made up of variable inductor L108, fixed capacitor C137, and trimmer C136); in the 3.0-6.0 position, Z108 (made up of variable inductor L109 and trimmer C138); in the 6.0-12.0 position, Z109 (made up of variable inductor L110 and trimmer C140); and in the 12.0-20.0 position, Z110 (made up of variable inductor L111 and trimmer C141). All variable inductors are connected to the tuning mechanism. To prevent spurious oscillations, the three unused tank circuits are shorted by section 2 front of the BAND SELECTOR. The signal developed across the selected tank circuit is coupled through capacitor C142 to receptacle J103, from which it is fed over coaxial cable to the power amplifier grid circuit. The plate circuit of V104 is decoupled by capacitor C139, which is grounded through contacts 2 and 1 of K101. The intermediate amplifier plate current may be read on meter M2 when EXCITATION METER SWITCH S3 is in the INT AMP X10 position. Resistor R7 is the meter shunt.

*c.* When SERVICE SELECTOR switch S1 is placed in the EXT EXC position, 26.5 volts ac (also used for the filaments of V104) is supplied to energize external excitaton relay K101. Relay K101 then removes the multiplier output signal from the grid of V104 and supplies this grid with an input signal from EXT EXC jack J15. Jack J15, on the front panel of the RF deck, is connected to K101 through coupling capacitor C154. With K101 energized, the direct ground connection is removed from the cathode of V104. The cathode is then returned to ground through bias resistor R121, bypassed by capacitors C135 and C155. The bias developed across R121 prevents excessive plate current flow in V104 when the blocking bias is removed or no excitation is present. When K101 is energized, decoupling capacitor C139 is tied back to the cathode of V104 rather than to ground. With these exceptions, the circuit elements of V104 function for EXT EXC operation exactly as described in *a* and *b* above.



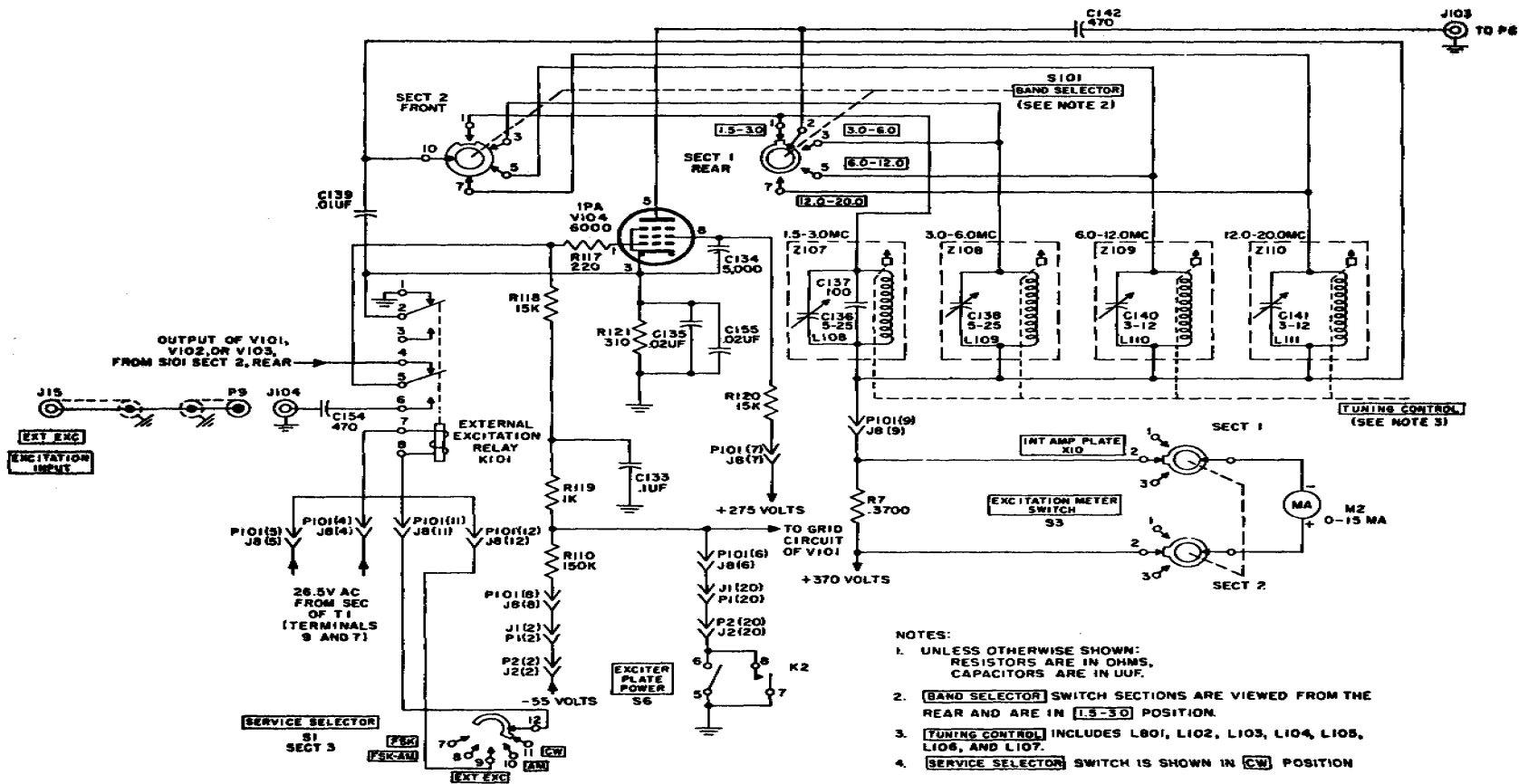
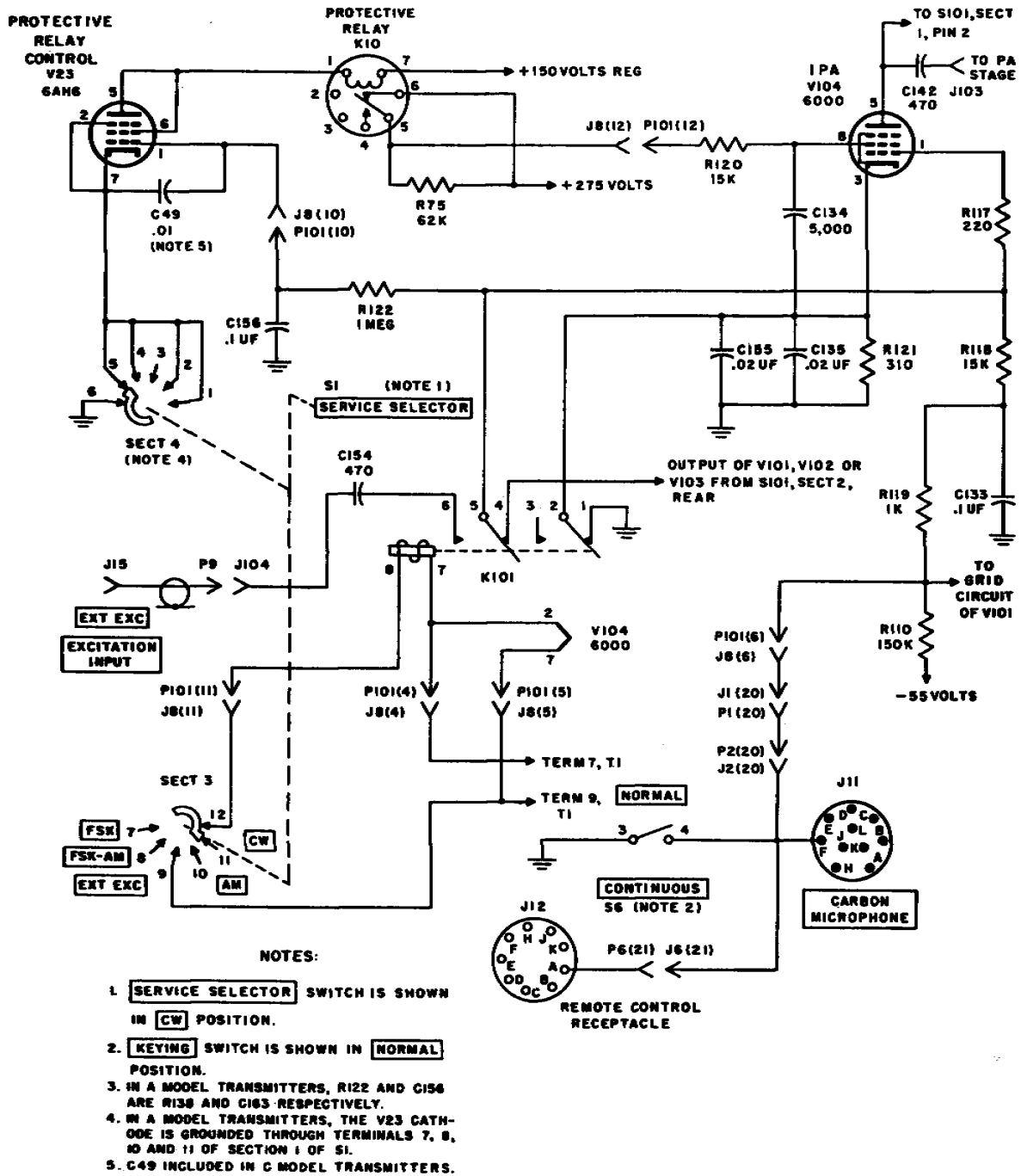

Figure 7. Intermediate power amplifier stage.



TM 809-35-5

Figure 8. Intermediate power amplifier stage protective relay circuit (lettered model transmitters only).

## 8. Power Amplifier and Clamper Stages

(figs. 9 and 10)

*a.* Power amplifier tube V1 (type 4-400A) receives the RF output of ipa V104 at connector P8 (and through parasitic suppressors R122 and R123 (fig. 10) in the A model transmitter) and is operated as a class C amplifier. Operating bias is developed when the grid excitation voltage causes grid current flow through RF choke L9 and resistors R1, R2, and R8. Clamper V2 (type 5933) prevents excessive plate current flow through the pa when its grid is not excited. As long as grid excitation is present, the clamper is cut off by the bias developed across R1, R2, and R8. When excitation is lost and there is no clamper bias, the clamper conducts heavily through its plate load resistor, R4, which is connected to the high-voltage supply in the power supply deck through spring contacts E3 and E4. Since R4 is also the screen dropping resistor for the power amplifier, loss of excitation drops the power amplifier screen voltage, thereby reducing the power amplifier plate current to a safe value. Capacitor C2 maintains the clamper grid at RF ground potential and also filters RF out of the pa grid excitation meter circuit. The dc level of this excitation can be read on meter M2 when EXCITATION METER SWITCH S3 is in the PA GRID X2 position. Resistor R8 is the meter shunt. Resistor R137 in the V2 grid circuit (A model transmitter only) prevents possible parasitic oscillations. FIL VOLTAGE meter M1 reads the power amplifier filament voltage, which is supplied from a secondary of filament transformer T1. Capacitors C3 and C4 place the filament at RF ground potential. Capacitor C5 places the pa screen grid at zero RF potential.

*b.* The output of V1 is applied to the antenna through a parasitic trap (L1 and R3), a tuned pi-network, a tuned L-type coil and capacitor network, and an antenna changeover relay. The pi-network is used because of its effectiveness in attenuating undesired harmonics. Along with an L-network, the pi-network is also effective in matching the high output impedance of the power amplifier to a wide range of lower antenna load impedances. The pi-network includes POWER AMPLIFIER TUNING variable vacuum-type capacitor C6, inductor L2 (tapped by P A BAND SWITCH S2,

section 2), and POWER AMPLIFIER LOADING variable vacuum-type capacitor C9. The POWER AMPLIFIER LOADING tuning capacitor also functions as the input impedance arm of the L-network. The other arm of the L-network contains that portion of inductor L4 tapped by P A BAND SWITCH S2, section 1. The two networks are coupled by parallel capacitors C7, C41, and C42. When S2 is set for the desired band, C6 is used to tune the pi-network to resonance. Capacitor C9 is used to vary the loading so that the pa tube will work into its recommended impedance of 3,000 ohms. The low impedance from the antenna is reflected through the used portion of L4 and effectively increased to match the pa tube load impedance. When the pi-network is properly adjusted, the output impedance of V1 will differ radically from the optimum value of 3,000 ohms for all harmonics of the frequency used; this adjustment helps decrease harmonic radiation to a negligible value. P A BAND SWITCH S2 also operates microswitch S4 in the primary circuit of the high-voltage supply. Microswitch S4 is opened momentarily during band switching to prevent excessive plate current flow through the power amplifier while the stage is improperly loaded and to prevent arcing of the contacts of switch S2. The RF output from the L-network is fed through spring contacts E5 and E6 to RF OUTPUT jack J9 through antenna changeover relay K1B in the basic model (K1 in the A model, K11 in the B and C models). Until the relay is energized, the RF output line is grounded through R66 and the relay contacts. The function of R66 is performed by R136 in the A model transmitter. Resistor R66 is 47 ohms to approximate the load impedance (50 to 52 ohms) the antenna presents to the pa plate circuit. Under key-up conditions, the antenna is disconnected, but R66 is connected into the circuit to load the pa circuit in the same manner. The RF energy in the tank circuits is dissipated across the resistance of R66 to prevent damped waves from distorting the trailing edge of the keyed pulse. (Changing the load in this manner does not damage the power amplifier tube, because in the key-up condition no excitation is present and clamper V2 operates to minimize the power amplifier plate current.) Disconnecting the RF output line from J9 during

AGO 2742A

key-up periods permits the transmitter antenna to be used as a receiving antenna for a suitable receiver connected to RECEIVER jack J10. RF choke L10 (which presents high reactance to RF voltages and, therefore, has no effect on the transmitter RF output) provides a low dc resistance to ground. If dc blocking capacitor C7, C41, or C42 were to become shorted, heavy current would be drawn through V1 from the high-voltage power supply. This would cause overload relay K4 to operate and remove the high voltage

preventing high voltage from appearing at antenna terminal J9.

c. The power amplifier plate is shunt fed through 1 millihenry RF choke L3 in series with P A PLATE meter M3 and the secondary of modulation transformer T5. The high-voltage line is connected from the power supply deck through the modulator deck to the RF deck by spring contacts E1, E2, E3, E4, E7, E8, E9, and E10. Capacitor C10, with L3, filters RF out of the meter circuit and power supply.

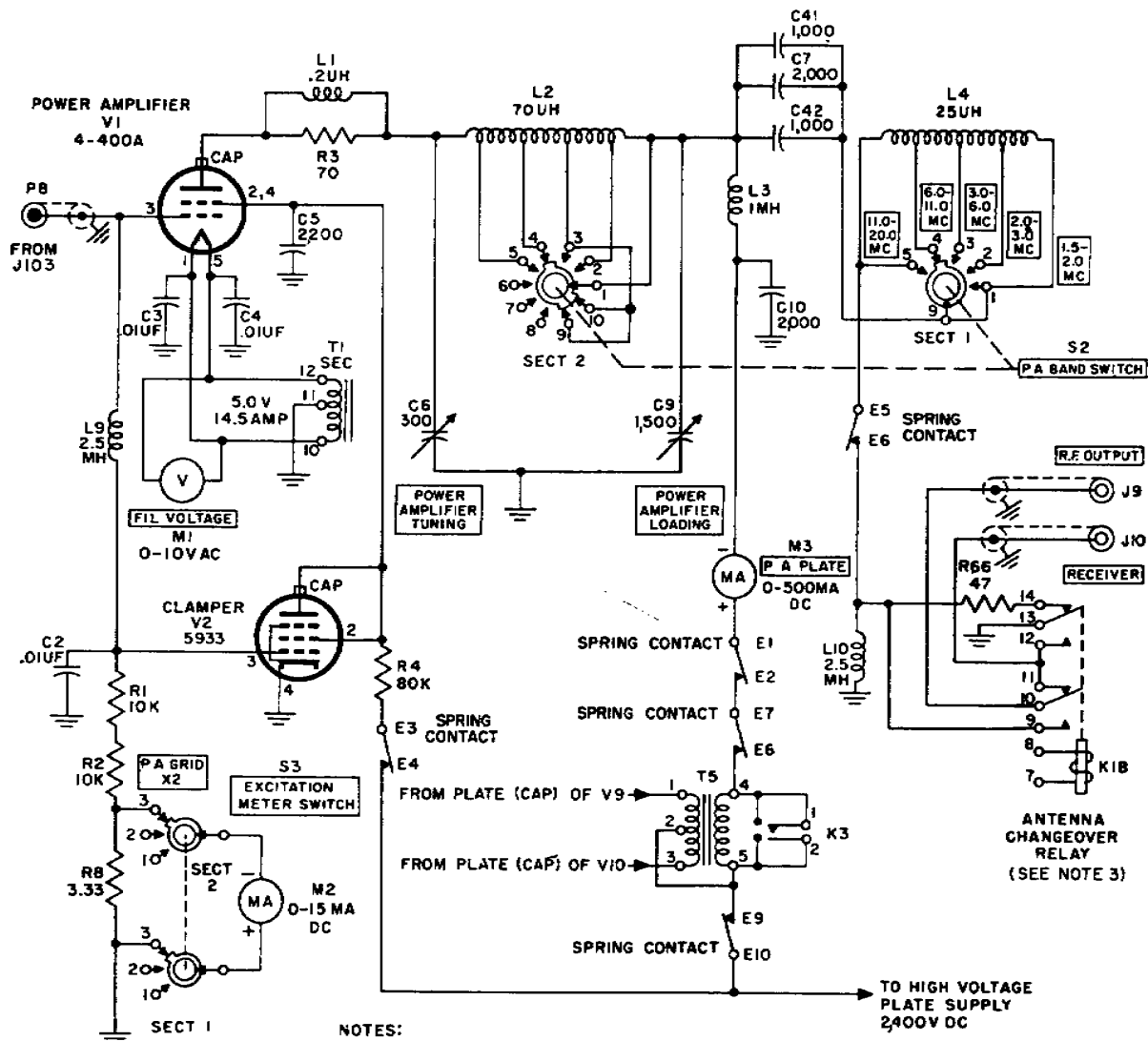

NOTES:

1. UNLESS OTHERWISE SHOWN; RESISTORS ARE IN OHMS, CAPACITORS ARE IN UUF, INDUCTORS ARE IN MH.
2. PA BAND SWITCH IS SHOWN IN THE 6.0-11.0 MC POSITION.
3. IN B AND C MODEL TRANSMITTERS, K11, WITH DIFFERENT TERMINAL NUMBERS, IS USED. REFER TO MAIN SCHEMATIC DRAWING.

TM 809-35-6

Figure 9. Power amplifier and CLAMPER stages, basic, B, and C models.

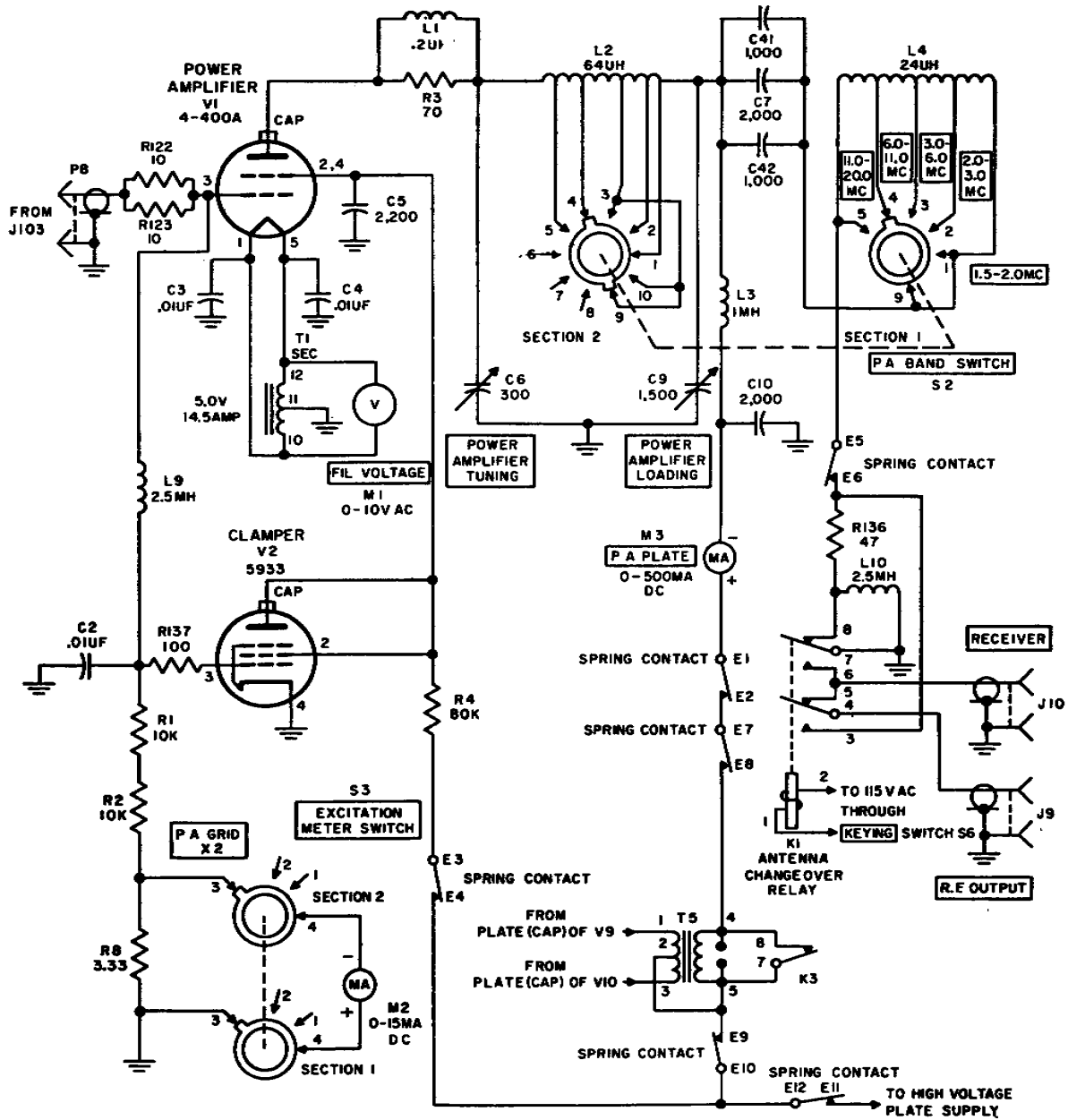

- NOTES:
1. UNLESS OTHERWISE SHOWN: RESISTORS ARE IN OHMS AND CAPACITORS ARE IN UUF.
  2. [P A BAND SWITCH] IS SHOWN IN THE [6.0-11.0MC] POSITION.

TM 809-C4-4

Figure 10. Power amplifier and clamper stages, A modes.

AFO 2742A

## 9. First, Second, and Third AF Amplifier Stages (figs. 11 and 12)

a. First AF amplifier V12A and second AF amplifier V12B are preamplifiers for a remote 600-ohm line input and a carbon microphone input, respectively. The telephone input is impressed across 600 OHM LINE GAIN potentiometer R17. The center arm is connected to the grid of V12A through shielded cable, connector P5, and receptacle J5. To reduce hum pickup, the cable shield is grounded at the speech-amplifier end only. The carbon microphone is supplied with do operating potential from the bias supply. This potential varies at an AF rate as the voice input varies the resistance of the carbon granules. The AF signal is RC coupled through dc blocking capacitor C20 and impressed across CARBON MIKE GAIN potentiometer R16. The arm of R16 is connected to the grid of V12B through shielded cable, P4, and J4.

b. Preamplifiers V12A and V12B are similar in design, differing only in the values of their cathode bias resistors. Preamplifier V12A is biased by cathode resistor R26 (200 ohms), while V12B is biased by cathode resistor R28 (1,000 ohms). In the A model transmitter, V12A is biased by a 360-ohm resistor and bypass capacitor C162 is added to the cathode circuit. The cathode of V12B uses an 820-ohm resistor bypassed by C156. The bias differences make the gain of V12A greater than the gain of V12B. The two stages are designed in this manner to equalize the 600-ohm line and carbon microphone signals fed to third AF amplifier tube V13A, because of a difference in their input levels. The V12A and V12B tube circuits are otherwise identical. Resistors R27 and R29 are plate load resistors. The decoupling networks are formed by R41 and C27 (for the plate of V12A) and by R42 and C28 (for the plate of V12B). Capacitor C22A or C22B (C22 or C159 in the A model transmitter) couples the output

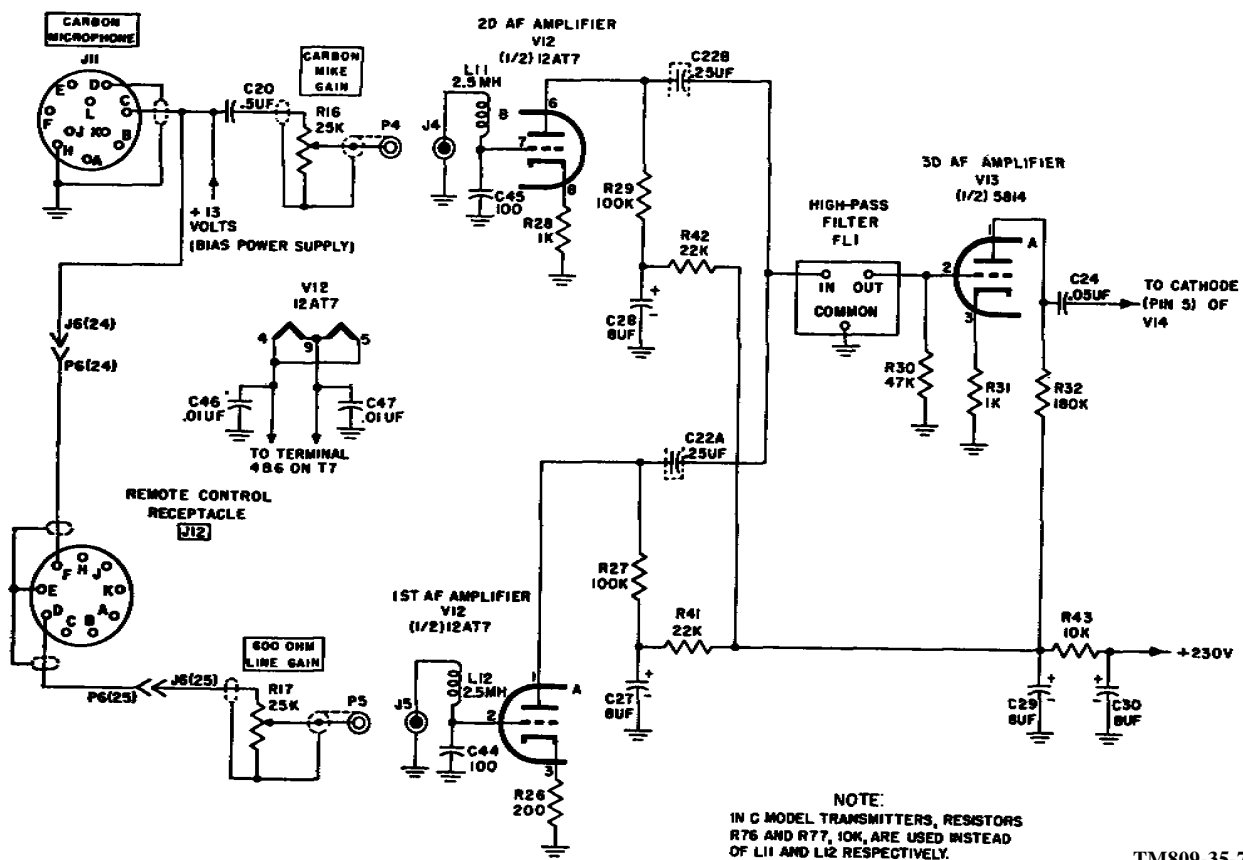

TM809-35-7

Figure 11. First, second, and third AF amplifier stages, basic, B, and C model transmitters.

of V12A or V12B to the grid of V13A through high-pass filter FL1. Filter FL1 determines the low-frequency response of the speech amplifier.

c. The signal that appears across grid load resistor R30 is amplified by third AF amplifier tube V13A and fed to a speech clipper stage through C24. Resistor R31 is the cathode bias resistor, R32 is the plate load resistor, and resistor R43, with capacitors C29 and C30, forms the decoupling network.

## 10. Clipper Stage

(fig. 13)

a. Clipper tube V14 clips high-amplitude voice input signals to insure a relatively constant speech-amplifier output level and prevent over modulation. The clipping action is controlled by potentiometer R44, which, with resistor R45, forms a voltage divider across the +250-volt supply. The output of third AF amplifier V13A is coupled through capacitor C24 and appears across cathode resistor R33. If no clipping is desired, R44 is set (extreme counterclockwise) so that the potential at its arm is maximum (theoretical value, approximately 140 volts). The no-signal current (dc) flow through the two halves of V14, their cathode

resistors R33 and R35, and common plate resistor R34, then establishes a potential of approximately +7 volts both at the clipper cathodes (pins 5 and 1) and the clipper plates (pins 2 and 7). This potential can be calculated by regarding the diode circuit as a series resistance of 90 kilohms (R33 and R35 in parallel), the resistance of each conducting diode section being negligible.

b. Under the above conditions, a positive half-cycle of the input signal, which appears across R33, will tend to cut off the first half of V14. The voltage at the plate (pin 2), however, will increase because of less drop across R34; this keeps current flowing through R33 and R35 in parallel until actual cutoff is reached. When the first half of V14 is cut off, it becomes an open circuit, and the voltage at the plates and cathodes of the clipper is determined by the drop across R35 and the second half of V14 alone. The maximum value that this voltage can attain is approximately +13 volts (180 kilohms in series with R34 across +140 volts). Thus, a positive half-cycle of the input, which is +6 volts or less at its peak, will be faithfully reproduced across resistor R35. (A signal peak

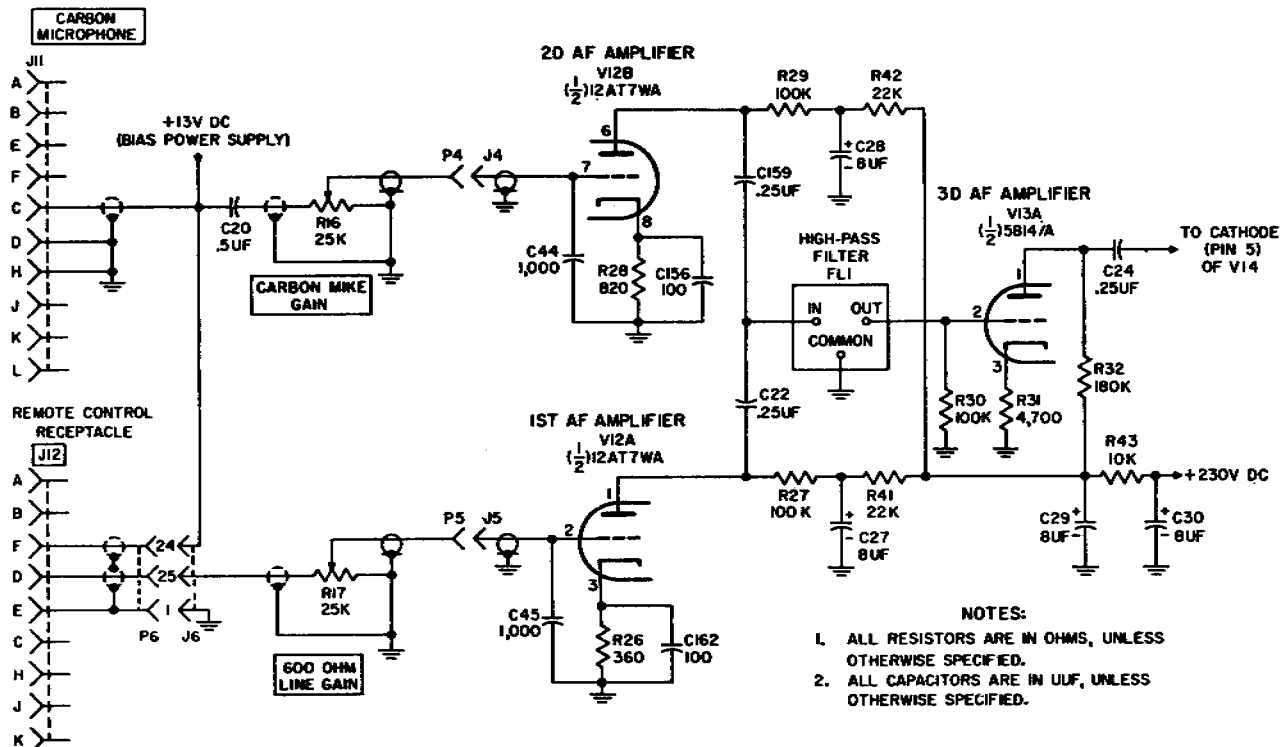

TM809-35-8

Figure 12. First, second, and third AF amplifier stages, A model transmitter.

AGO 2742A

greater than this would be clipped, but signals greater than 6 volts, peak, are not normally received from third AF amplifier V13A.) On negative half cycles of the input signal, the saturation characteristics of the diode limit the maximum current flow through the first half of V14. The saturation current is such that the plate (pin 2) voltage and therefore the cathode (pin 1) voltage cannot fall below approximately +1 volt, regardless of the negative input signal amplitude. This permits a negative input peak of -6 volts (greater than normal) before clipping starts.

c. Clipping is produced by setting potentiometer R44 for a smaller voltage at its arm. If the supply is set at +70 volts, for example, the static dc potential at the plates and cathodes of V14 is approximately +3 volts. The maximum voltage at the plates and cathodes, reached when a positive input cuts off the first half of the clipper, is approximately +6.5 volts. Thus, only positive half cycles +3.5 volts or less at their peaks will be faithfully reproduced across R35. Saturation of the first half of V14 on negative half cycle inputs clips all negative peaks above -3.5 volts. Clipping is increased by adjusting R44 for a still smaller supply voltage.

d. Clipping introduces some distortion, particularly of the higher audio frequencies. The effects of this distortion are greatly reduced by low-pass filter FL2, which is inserted between the clipper output and fourth

AF amplifier V13B to determine the high-frequency response of the speech amplifier. Capacitor C25 is a coupling capacitor. Resistor R60 is a termination resistor for filter FL2.

## 11. Fourth AF Amplifier and AF Driver Stages (fig. 14)

a. Fourth AF amplifier tube V13B provides sufficient voltage amplification of the signal received from the clipper stage to drive speech amplifier output driver tube V15. The circuit is an RC coupled amplifier. Resistors R36, R37, and R38 are the grid leak, cathode bias, and plate load resistors, respectively. Resistor R46 and capacitor C30 form a decoupling network. Plate voltage variations are coupled to the grid of AF driver V15 through capacitor C26.

b. The signal that appears across grid load resistor R39 is amplified by V15 and developed across the primary of speech-amplifier output transformer T6. The plate of V15 is coupled back to the cathode of V13B through resistor R61 and capacitor C40 to provide degenerative feedback to improve the linearity of the output. The secondary of T6 is center-tapped to provide a push-pull input for modulators V9 and V10 and is returned to the modulator bias supply. Resistor R40 is the AF driver cathode bias resistor, and C21 is its bypass.

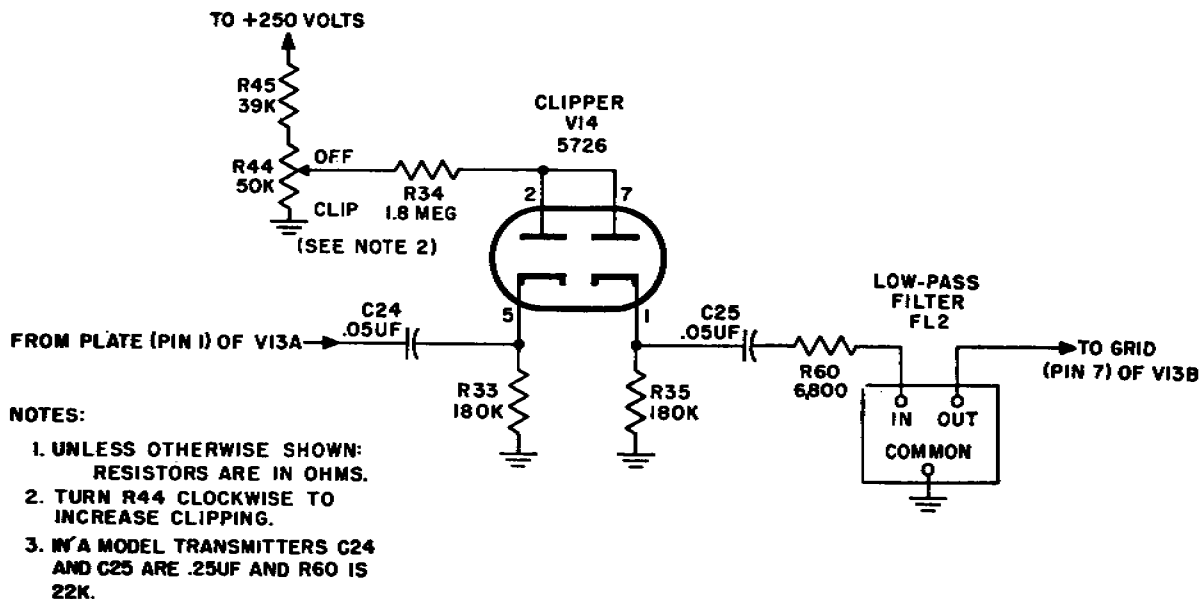

TM809-35-9

Figure 13. Clipper stage, functional diagram.

AGO 2742A



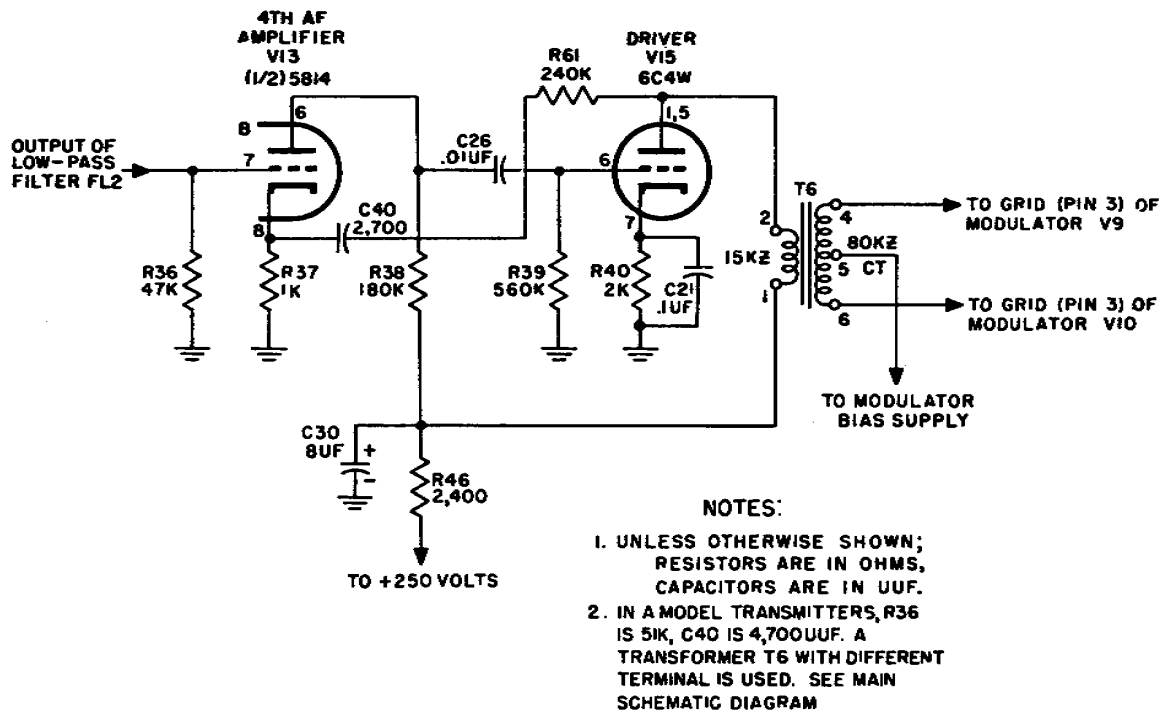

TM809-35-10

Figure 14. Fourth AF amplifier and AF driver stages.

## 12. Modulator Stage

(figs. 15 and 16)

a. Push-pull modulator tubes V9 and V10 plate-modulate the power amplifier when the transmitter is used in either FSK-AM or AM operation. The stage is made operable by energizing CW-phone relay K3 when in the above services (par. 18h). With K3 deenergized, both modulator tubes are biased beyond cutoff by a large negative voltage obtained from the bias power supply. In the A model transmitter (fig. 16), the -385 volts is applied to the V9 and V10 grids through R135 and the center-tapped secondary of T6. In the other models, cutoff bias is applied through K3 and the center-tapped secondary of T6. An additional disabling function of K3 is that it shorts the secondary of modulation transformer T5. When K3 is energized, operating bias for the modulators is obtained from the arm of MODULATOR BIAS potentiometer R25 and the short circuit is removed from the secondary of T5.

b. The input signal received from the AF driver stage in the speech amplifier is increased in power by V9 and V10. The push-pull outputs of V9 and V10 are developed across the center-tapped primary of T5, the

secondary of which is part of the power amplifier plate circuit. The transformer secondary is protected against excessive voltages by a spark gap provided across terminals 4 and 5. The modulator screen grids, RF bypassed by capacitors C12 and C13, are regulated at +600 volts. The modulator filaments are supplied by modulator filament transformer T2. The secondary of T2 is center-tapped to provide a plate current return through meter shunt resistor R9. The plate current may be read on meter M2 when EXCITATION METER SWITCH S3 is in the MOD PLATE X20 position. Resistor R10 provides the plate current return if the connectors to the meter circuit are opened.

c. In SERVICE SELECTOR switch position other than AM or FSK-AM, the circuit to K3 and the circuit to modulator tube filament transformer T2 are opened.

## 13. Sidetone Oscillator and Cathode Follower Stages

(figs. 17-19)

a. The speech-amplifier chassis contains a sidetone oscillator tube (V17) which allows the

AGO 2742A

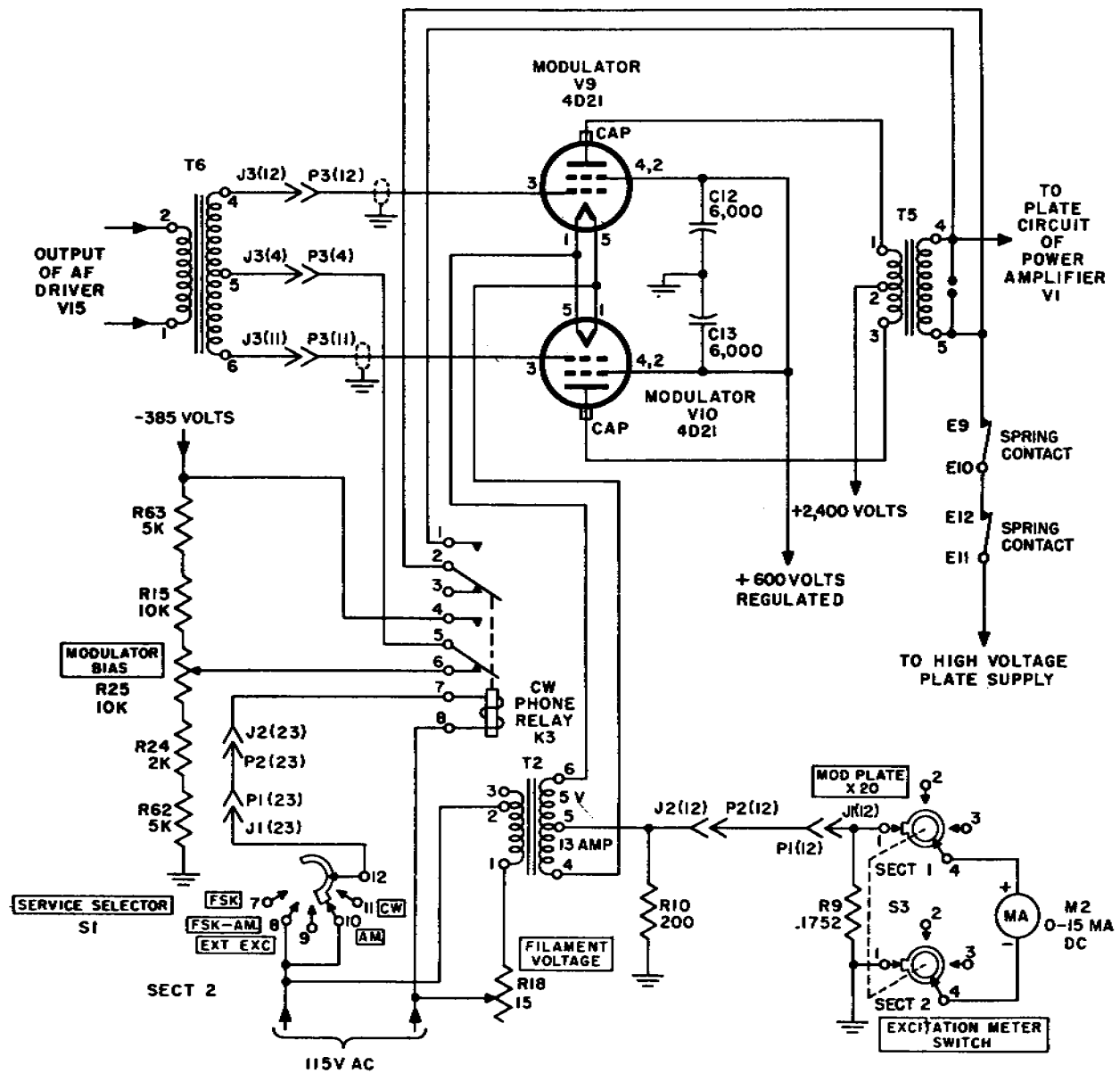

**NOTES:**

1. UNLESS OTHERWISE SHOWN; RESISTORS ARE IN OHMS, CAPACITORS ARE IN UUF.
2. **SERVICE SELECTOR** SWITCH IS VIEWED FROM THE REAR AND IS IN THE **AM** POSITION.
3. **EXCITATION METER SWITCH** IS VIEWED FROM THE REAR AND IS IN THE **MOD PLATE X 20** POSITION.

TM809-27

Figure 15. Modulator stage, basic, B, and C model transmitters.

AGO 2742A

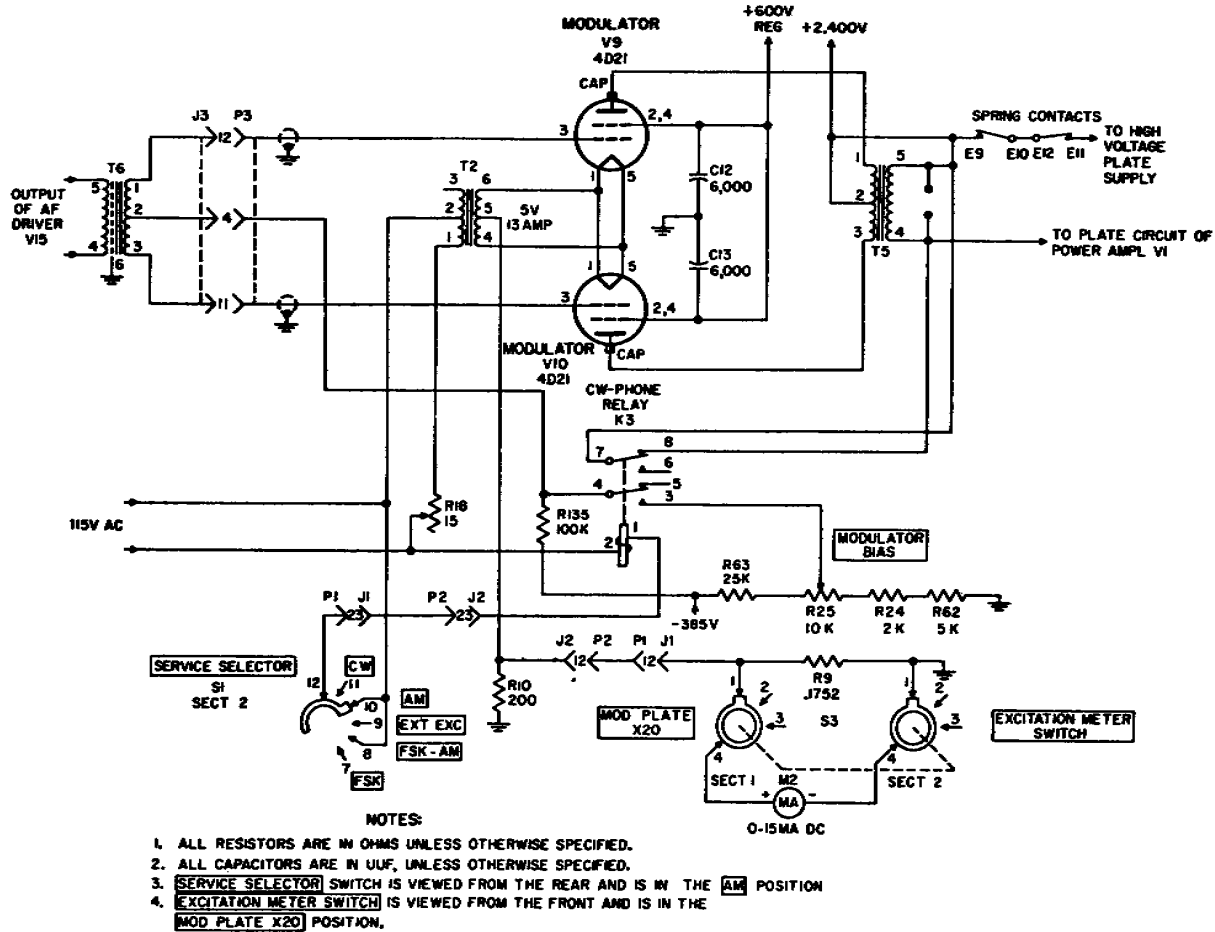

TM809-35-40

Figure 16. Modulator stage, A model transmitter.

operator to monitor his own CW keying. The oscillator is in operation only in the CW position because in all other positions the cathodes of V17 are left floating. During CW operation of the basic model, V17 is keyed (simultaneously with the transmitter) by energizing push-to-talk and key relay K2. During CW operation of the lettered models, V17 is keyed (simultaneously with the transmitter) by completing the circuit from terminal A of remote control receptacle J12 to ground. This grounds the control grid blocking circuit through resistor R50 (R50 and R126 in the A model) and allows the stage to operate. Sidetone oscillator V17 is a multivibrator-type oscillator which, when keyed, generates a 1,000-cycle tone.

b. In the basic model, V17 oscillations are started by a slight unbalance in the circuit that causes one half of the tube to be cut off while the other half is conducting.

Assuming that the first half of the tube (pins 6, 7, and 8) is cut off, its plate (pin 6) is at B+ potential (250 volts) and capacitor C33 is charged to that value. As C33 begins to discharge through grid resistor R50, the negative voltage developed across R50 reduces the current flow in the conducting half (pins 1, 2, and 3). This increases the plate (pin 1) voltage and causes capacitor C34, which had been nearly at ground potential, to charge through resistor R53. When the amplitude of the positive voltage developed across R53 is sufficient to overcome the cathode bias provided by resistor R52, the first half of V17 begins to conduct. (The time required before this conduction starts depends primarily on the C33-R50 time constant. The values of C33 and R50 determine the rate at which the current flow decreases in the conducting half and the time at

AGO 2742A

which the charging potential applied to C34 becomes sufficiently high.) When the first half of V17 conducts, C33 discharges still more rapidly through R50, driving the second half to cut off. This, in turn, increases conduction in the first half. The two halves of V17 remain in this reversed condition until the slow discharge of C34 through R53 initiates the next half cycle. The 1,000-cycle output is taken from across resistor R50 and coupled to the grid of cathode follower V16 through capacitor C32. Resistors R51 and R49 are plate resistors, and resistor R54, with capacitor C35, forms a decoupling network. While in the basic model either half of V17 may be cut off to start oscillation, in lettered model transmitters, one-half (pins 1, 2 and 3) is held at cutoff by bias applied to grid 2 through resistors R50 and R68 (R50, R126, and R127 in A model transmitters). Grid pin 2 is biased with a little less than -55 volts and is insensitive to the change in plate voltage when capacitor C34 becomes charged. Thus, under the cutoff condition, capacitor C34 is charged to almost 250 volts. Capacitor C33 is charged to the same voltage plus the bias voltage applied through resistor R50. When the bias is removed, capacitor C33 discharges through resistor R50 to the value of plate voltage on pin 6 minus the cathode bias. Both grids are now at approximately the same potential, that of the cathode,

and the unbalance will start the oscillations. When the key is released, grid 1 is again biased beyond cutoff and the oscillations are stopped.

c. Cathode follower tube V16 matches the high-impedance output of V17 to the low-impedance headset used for monitoring. Resistor R48 is the grid load resistor. Resistor R47, the cathode load resistor, also functions as the sidetone gain control. The output of V16 is coupled through capacitor C31 to pin H of remote control receptacle J12.

#### 14. Bias Power Supply

(figs. 20-22)

a. In the basic model transmitter, the bias supply provides both the cutoff and operating bias voltages for the modulator stage; the blocking bias voltage for the second buffer and first multiplier V101 and intermediate amplifier V104; and the energizing power for push-to-talk and key relay K2 and for slow-release relay K1A. It also supplies a low dc voltage necessary to obtain operating current for the carbon microphone. In lettered model transmitters, the bias supply provides both the cutoff and operating bias voltages for the modulator stage; the blocking bias voltage for second buffer and first multiplier V101, intermediate amplifier V104, protective relay control V23, and sidetone oscillator

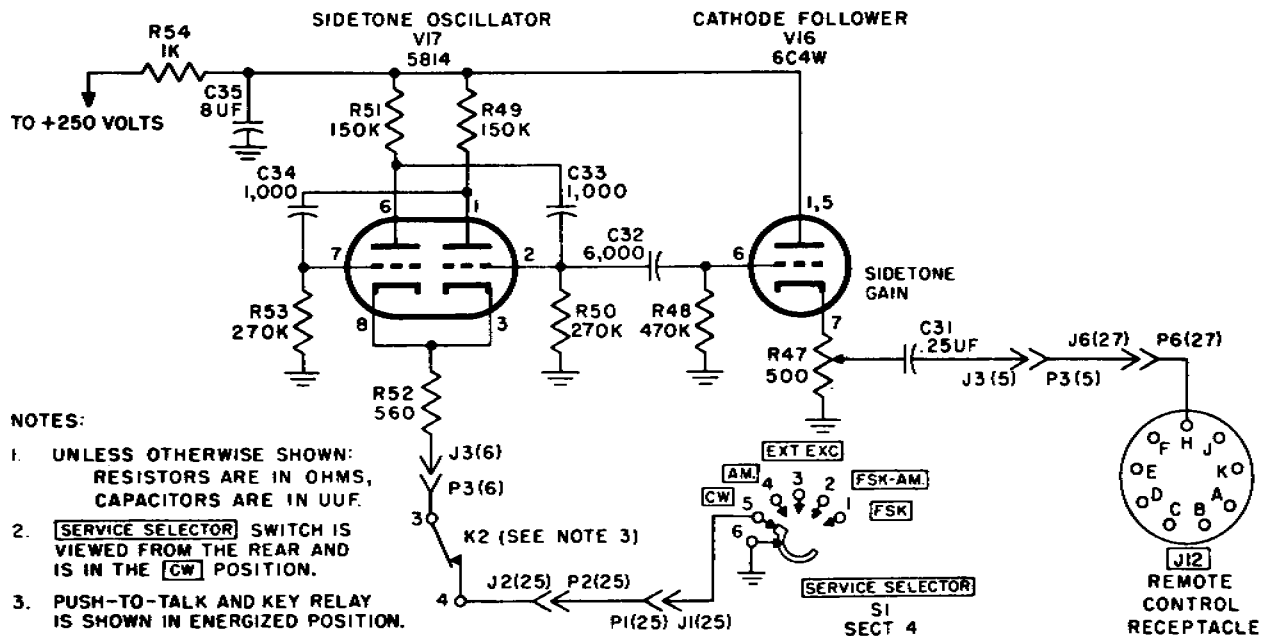

TM809-31

Figure 17. Sidetone and cathode follower circuits, basic model transmitters.

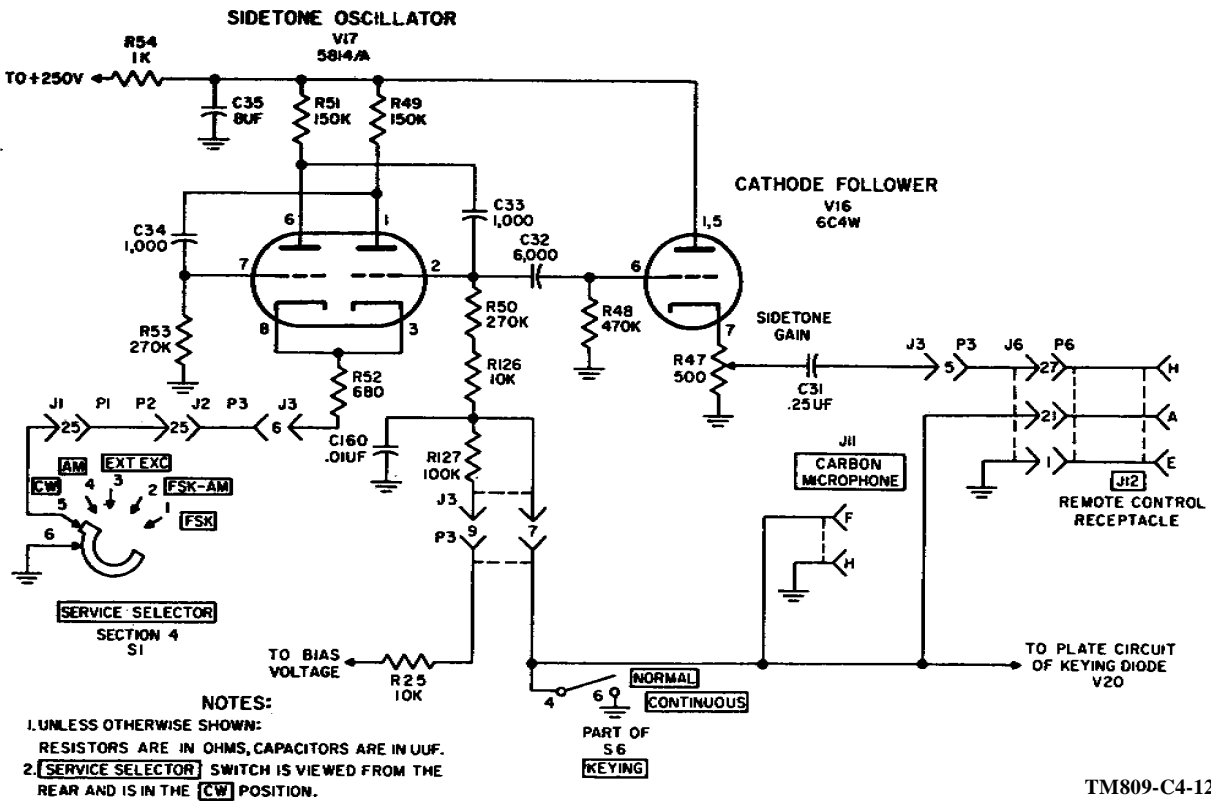

Figure 18. Sidetone and cathode follower stages, A model transmitters.

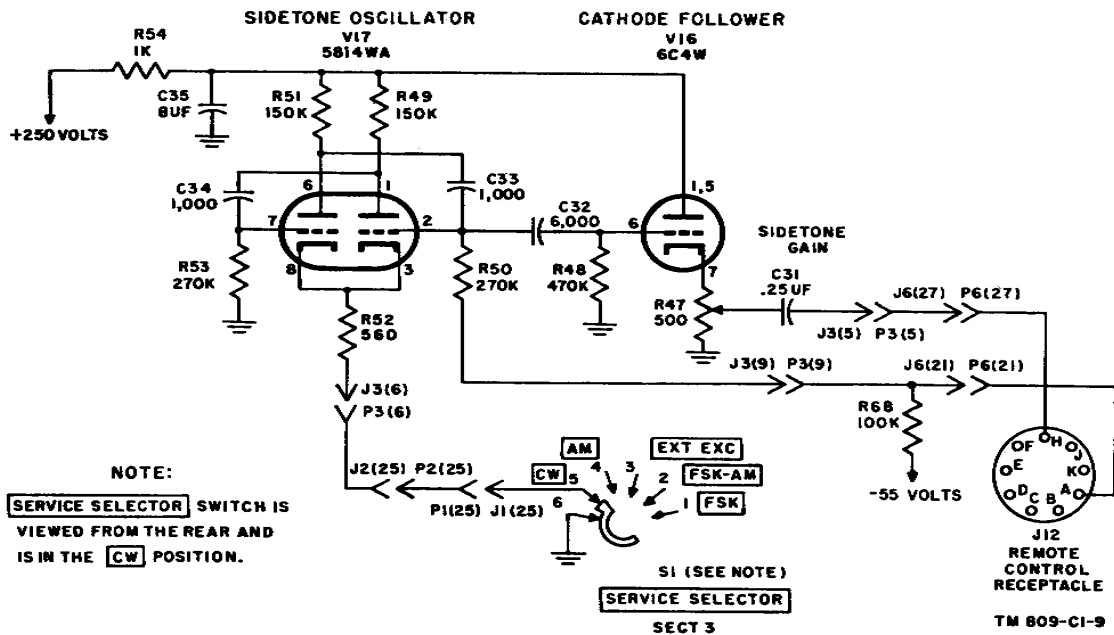

Figure 19. Sidetone and cathode follower circuits, B and C model transmitters.

V17; and the control voltage for the keying relay circuit consisting of keying diode V21, keying relay control V22, and slow release relay K9. (In the A model transmitter (fig. 21), the keying relay circuit consists of keying diode V20, keying relay control V21, and slow release relay K9.) It also supplies a low dc voltage necessary to obtain operating current for the carbon microphone.

*b.* When 115-volt ac power is applied to the primary of T4, its secondary supply filament and plate voltage to bias rectifier tube V11 as well as filament voltage to the exciter rectifier tube or tubes (lettered models). The full-wave rectified output of V11 is applied to a choke input pi-section filter which consists of chokes L6 and L7 and capacitors C16 and C19. The filtered output is impressed across a series-parallel voltage-dividing network which consists of R23 and R22, paralleled by R63, R15, R25, R24, and R62 in series with R19. In A model transmitters, R63 is increased in value and R15 is not used. All output voltages are tapped from this divider network.

*c.* In the basic, B, and C models, disabling grid bias for modulators V9 and V10, tapped from the most negative point on the divider, is applied through CW-phone relay K3 and the center-tapped secondary of speech-amplifier output transformer T6. When K3 is energized for FSK-AM and AM operation (par. 12 *a*), a reduced operating bias for the modulators is supplied from the arm of MODULATOR BIAS potentiometer R25 through contacts 6 and 5 of K3. In the A model transmitter, cutoff grid bias for modulators V9 and V10 is applied through resistor R135 and the center-tapped secondary of speech-amplifier output transformer T6. When K3 is energized for AM operation, a reduced operating bias for the modulators is supplied from the arm of MODULATOR BIAS potentiometer R25 through contacts 3 and 4 of K3 to T6.

*d.* Blocking bias for the blocked-grid keying of V101 and V104 is tapped from the junction of R24 and R62. In the basic model transmitter, resistor R110 limits the current drain on the supply when the blocking bias is removed. It does this by preventing R62 from being shorted to ground by contacts 7 and 8 of K2 or

operation of the EXCITER PLATE POWER switch. Power for energizing push-to-talk and key relay K2 and slow-release relay K1A is tapped from the junction of R23 and R22. In the B and C model transmitters (fig. 22), resistors R68 and R110 limit the current drain on the supply when the blocking bias line to the cutoff stages is grounded by any of the keying methods (par. 18g). Bias is applied to the plates of keying diode V21 through resistor R68, which also limits the current drawn through the voltage divider when bias is removed. The charge on capacitor C48, which cuts off keying relay control tube V22, is obtained across R69 through potentiometer R74. Resistors R69, R74, and R68 form a voltage divider across the -50-volt source. Cutoff bias on grid 2 of sidetone oscillator V17 is obtained from the junction of resistors R68 and potentiometer R74. Resistor R122 and capacitor C156 form a decoupling circuit and apply bias to protective relay control tube V23. In the A model transmitter, blocking bias for the blocked-grid keying of V101 and V104 is tapped from the junction of R63 and R25 through R110. Bias is applied to the plates of keying diode V20 through resistor R129 which limits the current drawn through the voltage divider when the keying circuit is grounded. The charge on capacitor C161, which cuts off keying relay control V21, is obtained across R130 through potentiometer R128. Resistors R129, R128, and R130 form a voltage divider across approximately 50 volts of the power supply. Cutoff bias on pin 2 of sidetone oscillator V17 is obtained from the junction of resistors R24 and potentiometer R25. Resistor R127 limits the current drawn on the supply by preventing the junction of R24 and R25 from being shorted to ground by keying action.

## 15. Exciter Power Supply of Basic, B, and C Model Transmitters

(figs. 23 and 24)

*a.* The exciter power supply provides dc operating voltages for the plate and screen circuits of all speech-amplifier and oscillator-multiplier tubes. In the B and C models, plate and screen voltage is also supplied to the keying relay control and protective relay control tubes. These stages are not used in the basic model transmitter. In the basic model transmitter, V4 is the

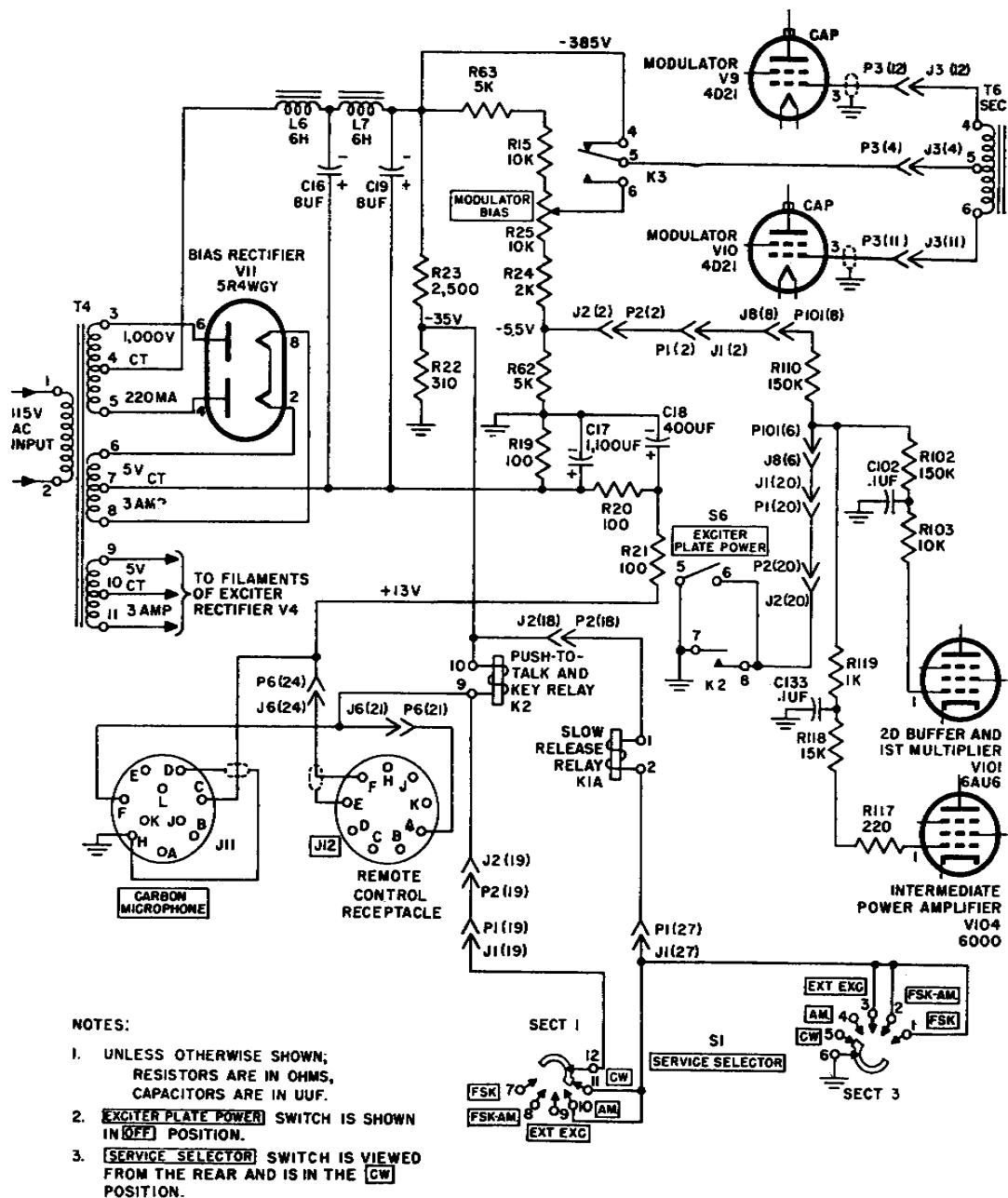

TM809-32

Figure 20. Bias power supply and distribution, basic model transmitters.

exciter rectifier; in the B and C models, V4 and V20 are used. Filament voltage for the exciter rectifier tubes is supplied from a secondary of T4 and is present as soon as primary power is applied. Plate voltage is supplied by exciter plate transformers T3. In the basic model trans-

mitter, the 115-volt ac input to T3 is either applied by relay K6 during AM. operation or permanently by exciter plate power switch S6, depending on the type of operation used. In lettered model transmitters, the 115-volt ac input to T3 is permanently applied when circuit

AGO 2742A

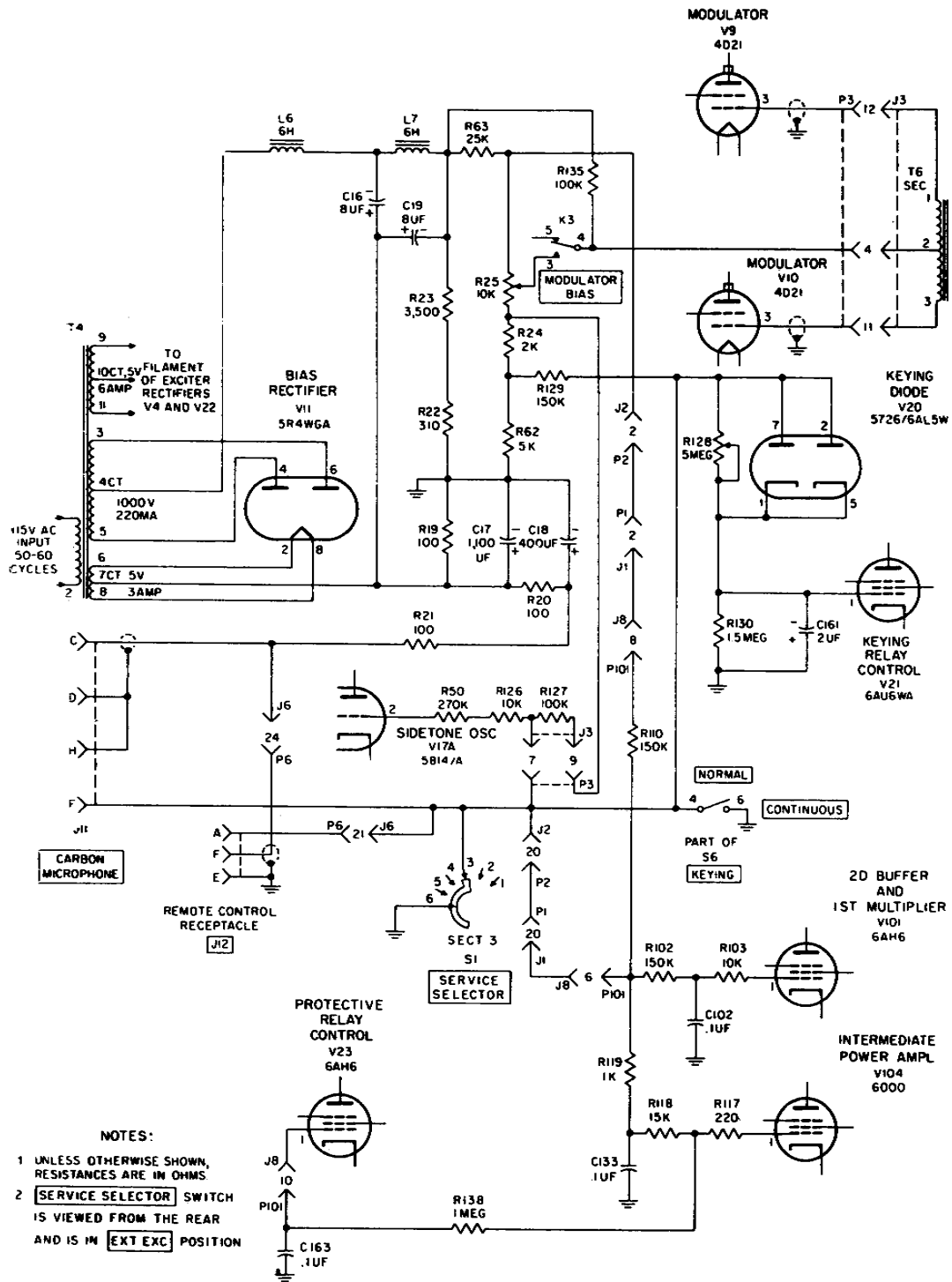
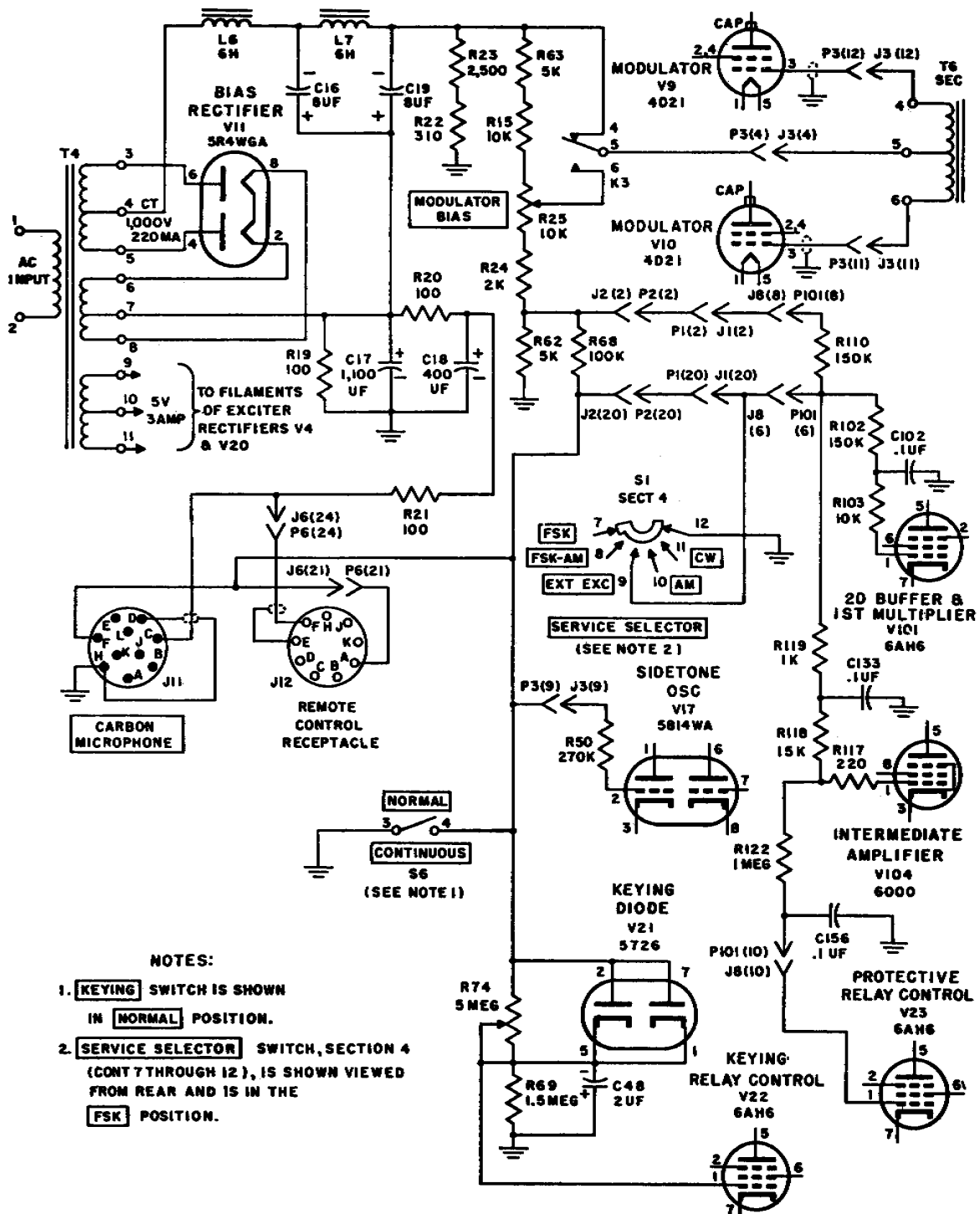

Figure 21. Bias power supply and distribution, A model transmitters.





TM809-C1-10

Figure 22. Bias power supply and distribution, B and C model transmitters.

AGO 2742A

breaker CB1 is set in the UP position. The full-wave rectified output of V4 is applied to a capacitor-input filter that consists of capacitors C14 and C15, choke L5, and resistor R13. Resistor R13 is not used in the B and C model transmitters. Resistor R14 is a bleeder resistor not used in the B and C model transmitters. The rectified and filtered output of the power supply is distributed to individual stages by paralleled voltage dividers as described in *b* through *e* below and in figures 23 and 24. To avoid duplication, detail material within the individual stages is omitted in figure 24 on B and C model transmitters. Refer to figure 23 or to the main schematic diagram for references such as TO PLATES OF V12 THRU V17.

*b.* Speech-amplifier plate voltages are obtained from taps on the voltage divider which consists of resistors R12, R45, and R44. Resistor R12 drops the supply voltage to +250 volts at the junction of R12 and R45. Plate current flow in V12A, V12B, V13A, V13B, and V15 through resistor R46 reduces the voltage at the junction of R43 and R46 to +230 volts. This voltage is applied to the plate of V13B through plate load resistor R38 and to the plate of V15 through the primary of T6. Preamplifiers V12A and V12B and third AF amplifier V13A are supplied through a common decoupling resistor, R43. The voltage at the junction of R43 and R42 is applied to the plate of V13A through plate load resistor R32. The plate voltages for V12A and V12B are reduced still further by dropping resistors R41 and R42, respectively. Resistors R27 and R29 are the respective plate load resistors. Capacitors C27 through C30 are decoupling capacitors. The plates of sidetone oscillator V17 and cathode follower V16 are supplied from +250 volts through decoupling resistor R54. Resistors R49 and R51 are the plate load resistors for V17, and C35 is a decoupling capacitor. Plate voltage for clipper V14 is obtained from the arm of potentiometer R44; its supply potential is variable from 0 to +140 volts. Resistor R34 is the clipper plate resistor.

*c.* Plate and screen voltages for the multiplier stages are obtained from taps on a second voltage divider which consists of resistors R64, R6, and R65. The plate of ipa tube V104 is supplied from the junction of R6 and R64 through meter shunt resistor R7 and the tank circuit

selected by section 1 rear of BAND SELECTOR switch S101. All other multiplier voltages are supplied from the junction of R6 and R65. Screen voltage for V104 is supplied through dropping resistor R120 (and, in the B and C models, through normally closed contacts 5 and 6 of K10 (par. 7a)). The plate and screen of V101 are supplied through decoupling resistor R107; plate voltage is supplied through R106 or Z101 depending on the position of S101, section 4 rear, and screen voltage is supplied through dropping resistor R105. The plate and screen of V102 are supplied through decoupling resistor R112; plate voltage is supplied through Z103 and screen voltage through resistor R111. The plate and screen of V103 are similarly supplied through decoupling resistor R116, tank circuit Z105, and screen dropping resistor R115. Capacitors C104, C117, C127, and C134 are RF bypasses. Capacitors C105, C106, C120, C129, and C139 are decoupling capacitors.

*d.* Plate and screen voltages for master oscillator V801 and first buffer V802 are tapped from the voltage divider which consists of resistor R5 and voltage regulator V3. Voltage regulator V3 regulates the supply to V801 and V802 at +150 volts. In the basic model transmitter, both stages are supplied through the AM or CW position of SERVICE SELECTOR switch S1, section 4, and RF choke L802. In the B and C model transmitters, they are supplied through the AM, CW, FSK, or FSK-AM position of S1, section 1, and RF choke L802. Resistors R803 and R806 are plate load resistors, and R802 and R805 are screen dropping resistors. Capacitors C806 and C808 are screen RF bypasses. Capacitors C810 and C152 are decoupling capacitors.

*e.* In the B and C model transmitters, an additional voltage divider consisting of resistors R70 and R71 is added. From the junction of these resistors, a circuit is completed to the plate of keying relay control V22 through plate load resistor R67 and the coil of slow release relay K9. Resistor R72 is the screen voltage dropping resistor for V22. In addition, the protective relay control tube, V23, is powered by the exciter power supply in B and C model transmitters. The plate and screen are tied together and receive a regulated +150 volts through the coil of protective relay K10 (par. 7).

AGO 2742A

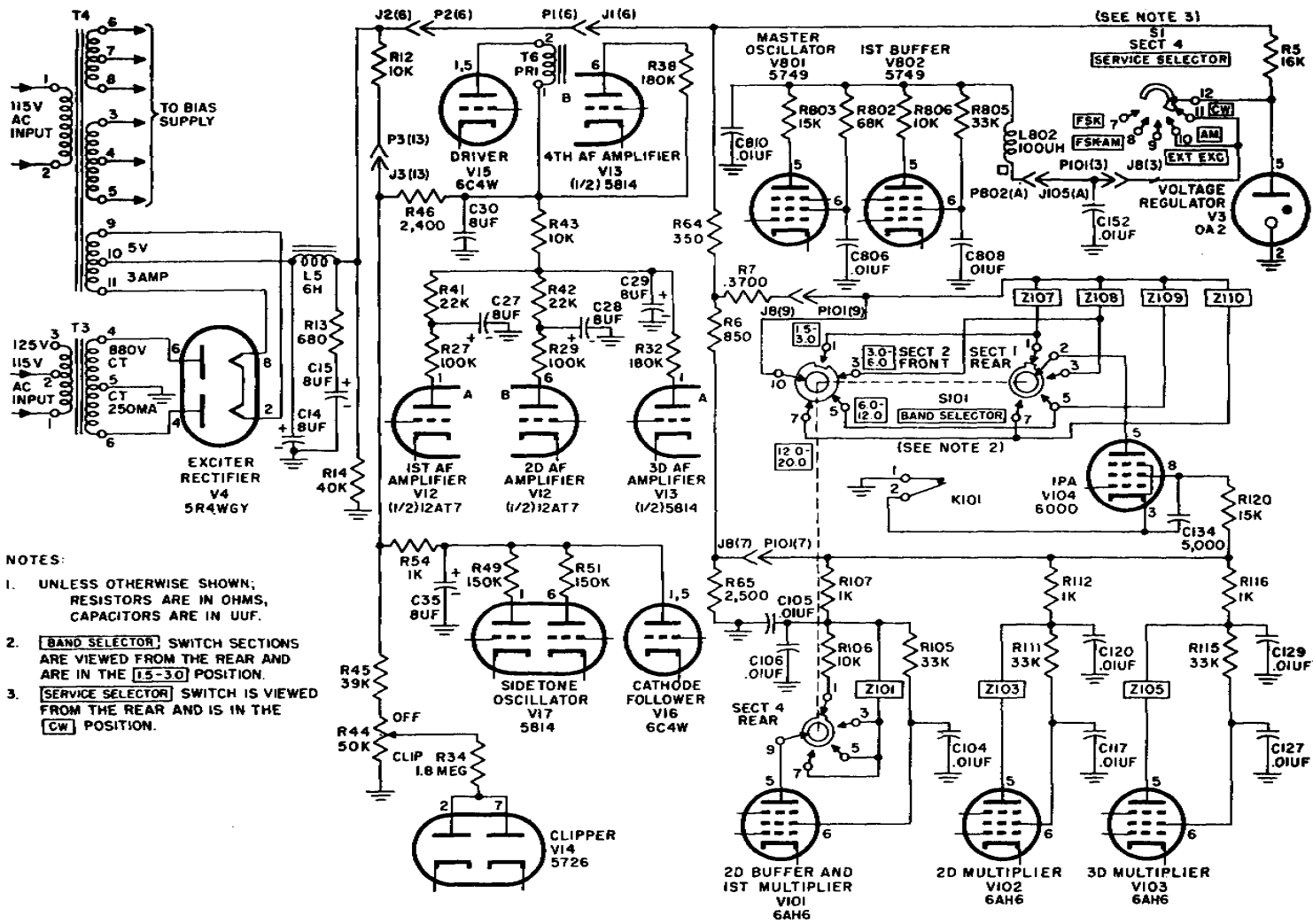

TM809-33

Figure 23. Exciter power supply and distribution, basic model transmitters.

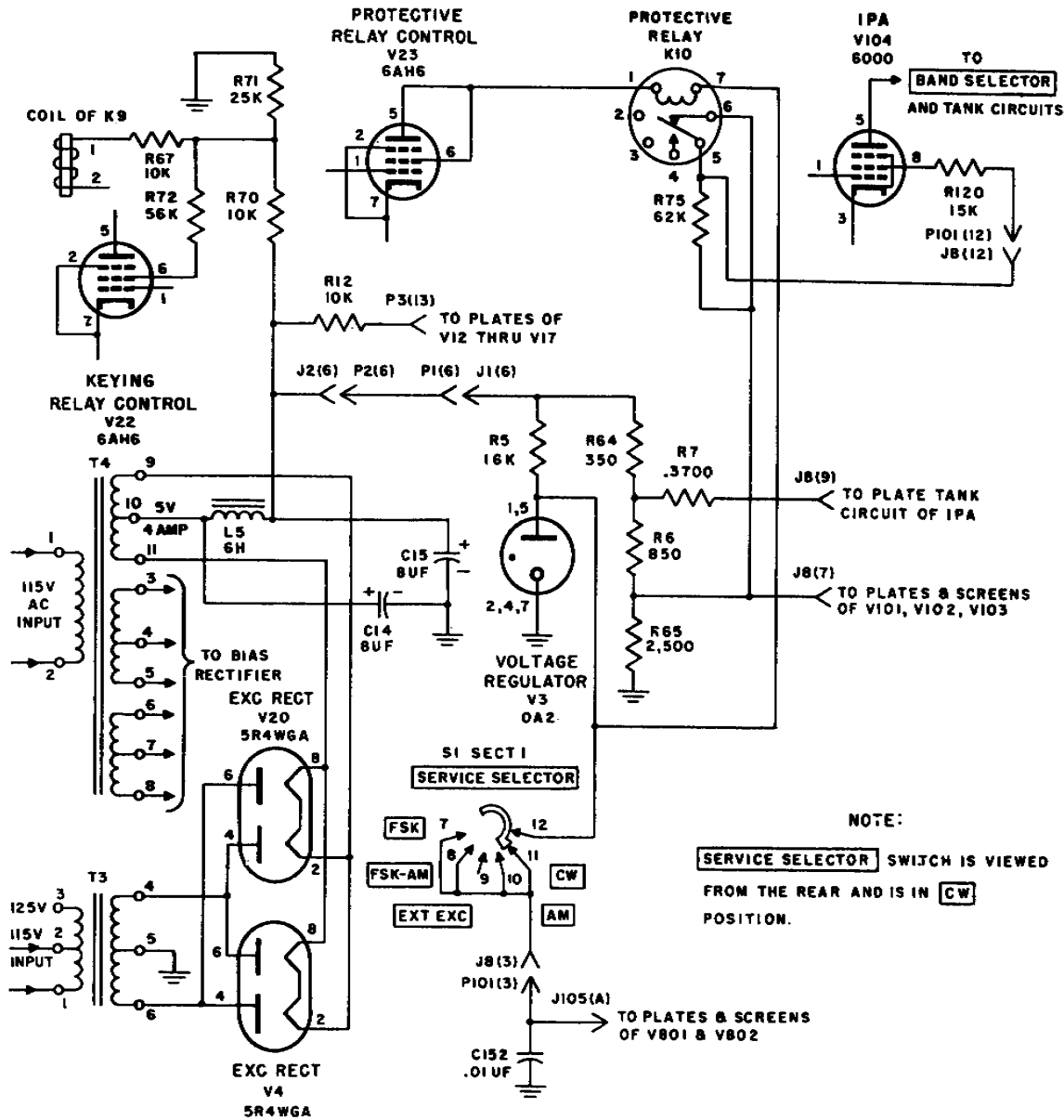

TM809-C1-11

Figure 24. Exciter power supply and distribution, B and C model transmitters.

## 16. Exciter Power Supply of A Model Transmitters

(fig. 25)

The exciter power supply provides dc operating voltages for the plates and screens of all tubes except final amplifier V1, clamper V2, keying diode V20, and modulators V9 and V10. Filament power for rectifier tubes V4 and V22 is supplied by T4 (terminals 9, 10, 11) and is present when the FILAMENT POWER

circuit breaker is closed. Primary power is also applied to T3, the exciter plate transformer, when the FILAMENT POWER circuit breaker is closed. The capacitor-input filter consists of C14, L5, and C15. There are four voltage-divider systems in parallel with bleeder resistor R14 across the output.

a. The first voltage divider, consisting of resistors R133 and R134, provides plate and screen voltages for keying relay control V21 through

AGO 2742A

resistors R132 and R131, respectively. The plate current is used to energize slow-release relay K9.

*b.* The second voltage divider, consisting of resistors R12, R45, and R44, provides voltages for the plates and screens of tubes V12 through V17 in the speech-amplifier chassis. The four audio amplifiers and the driver are fed through resistors R12 and R46. In addition to resistors R12 and R46, the current for V12 and V13A must flow through resistor R43. Resistor R54 and capacitor C35 form the decoupling network for sidetone oscillator V17 and cathode follower V16. Plate voltage for the clipper is adjustable and is set by resistor R44.

*c.* The third voltage divider, consisting of resistors R64, R6, R124, and R65, furnishes the plate and screen voltages for V101, V102, V103, and V104. Plate power for intermediate power amplifier V104 is tapped at the junction of resistors R64 and R6. The screen voltage for V104 is tapped at the junction of resistors R124 and R65. A protective circuit energizes protective relay K10 to limit ipa plate current to a safe value if excitation is removed. This opens contacts 5 and 6 of relay K10, removing the direct connection between resistor R120 and the power supply. Screen voltage for V104 is then obtained through the additional resistance of resistor R75.

*d.* The fourth voltage divider is made up of resistor R5 in series with voltage regulator tube V3. Regulated voltage (+150 volts) is applied to the plate and screen circuits of the master oscillator (V801) and first buffer (V802) through the SERVICE SELECTOR switch (section 4) in the AM or CW position. Plate current for protective relay control tube V23, which energizes relay K10, is furnished through the relay coil of K10 from voltage regulator V3.

## 17. High-Voltage Power Supply

(figs. 26 and 27)

*a.* The high-voltage supply in the power supply deck furnishes voltages for the plates and screens of power amplifier tube V1, clamper tube V2, and modulator tubes V9 and V10. The supply is protected against heavy current drains by an overload relay.

*b.* Filament voltage for high-voltage rectifier tubes

V18 and V19 is supplied by high-voltage filament transformer T8 and is available as soon as primary power is applied. The 115 volts ac input to high-voltage plate transformer T9 is available for application after a time delay (par. 18*c*); the input voltage may then be turned on only when the microphone switch is pressed (as in AM. operation) or applied permanently as in the other four types of operation. Red PLATE POWER indicator I4 lights to indicate the presence of the ac input. TUNE-OPERATE switch S12 (TUNE-NORMAL switch in A and certain C model transmitters), when placed in the TUNE position, inserts dropping resistor R11 in series with the double primary windings of T9. (In B and C model transmitters, T9 transformers with a single primary winding (fig. 27) are used.) Reducing the high voltage during tune-up procedures protects the RF power amplifier tube from excessive plate current flow while it is not properly loaded.

*c.* The full-wave rectified output of V18 and V19 is applied to a choke-input filter which consists of choke L8 and capacitors C38 and C39. A spark gap is placed across L8 to protect it against excessive voltages. Resistor R58 is a bleeder resistor across the power supply. The filtered output is applied to the load through the coil of overload relay K4 and its paralleled adjustment network (*f* below). The load is connected between the B+ line and ground, while K4 is connected between ground and the B- line.

*d.* High voltage is taken from the power supply deck through spring contacts E11 and E12, which serve as a high-voltage interlock. Voltage is applied to the plate and screen of clamper V2 and to the screen of power amplifier V1 through spring contacts E3 and E4 in the RF deck and through resistor R4. The plate of V1 is supplied in series with the secondary of modulation transformer T5, and high voltage for it and for the modulator tubes is applied through spring contacts E9 and E10 in the modulator deck. Terminal 4 of T5 is connected to the power amplifier plate through spring contacts E7 and E8 in the modulator deck, spring contacts E1 and E2 in the RF deck, P A PLATE meter M3, RF choke L3, the used portion of tuning inductance L2, and parasitic trap R3 and L1. Capacitor C10 is an RF bypass capacitor. Capacitor C9,

AGO 2742A

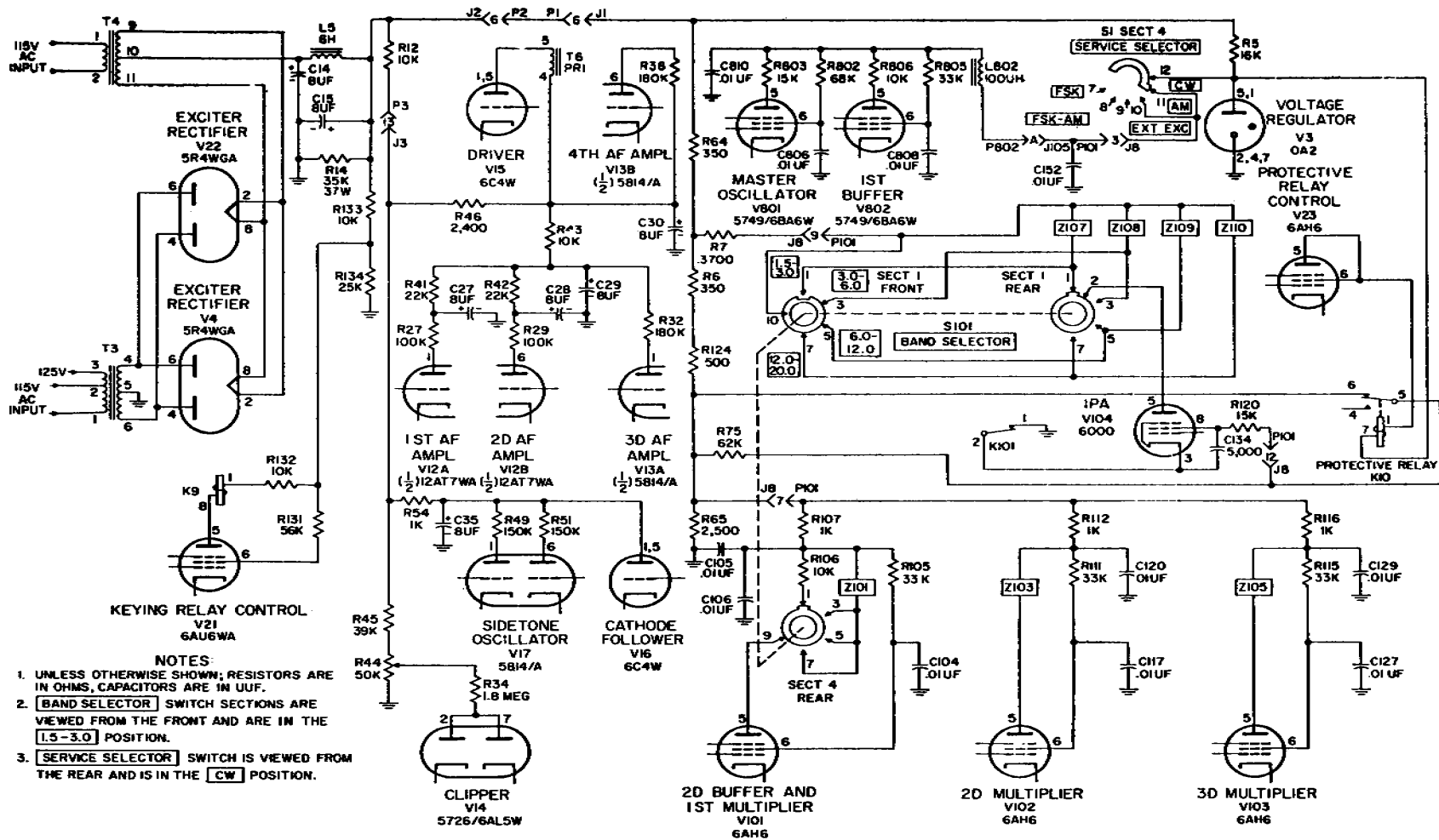

TM809-C4-26

Figure 25. Exciter power supply and distribution, A model transmitters.

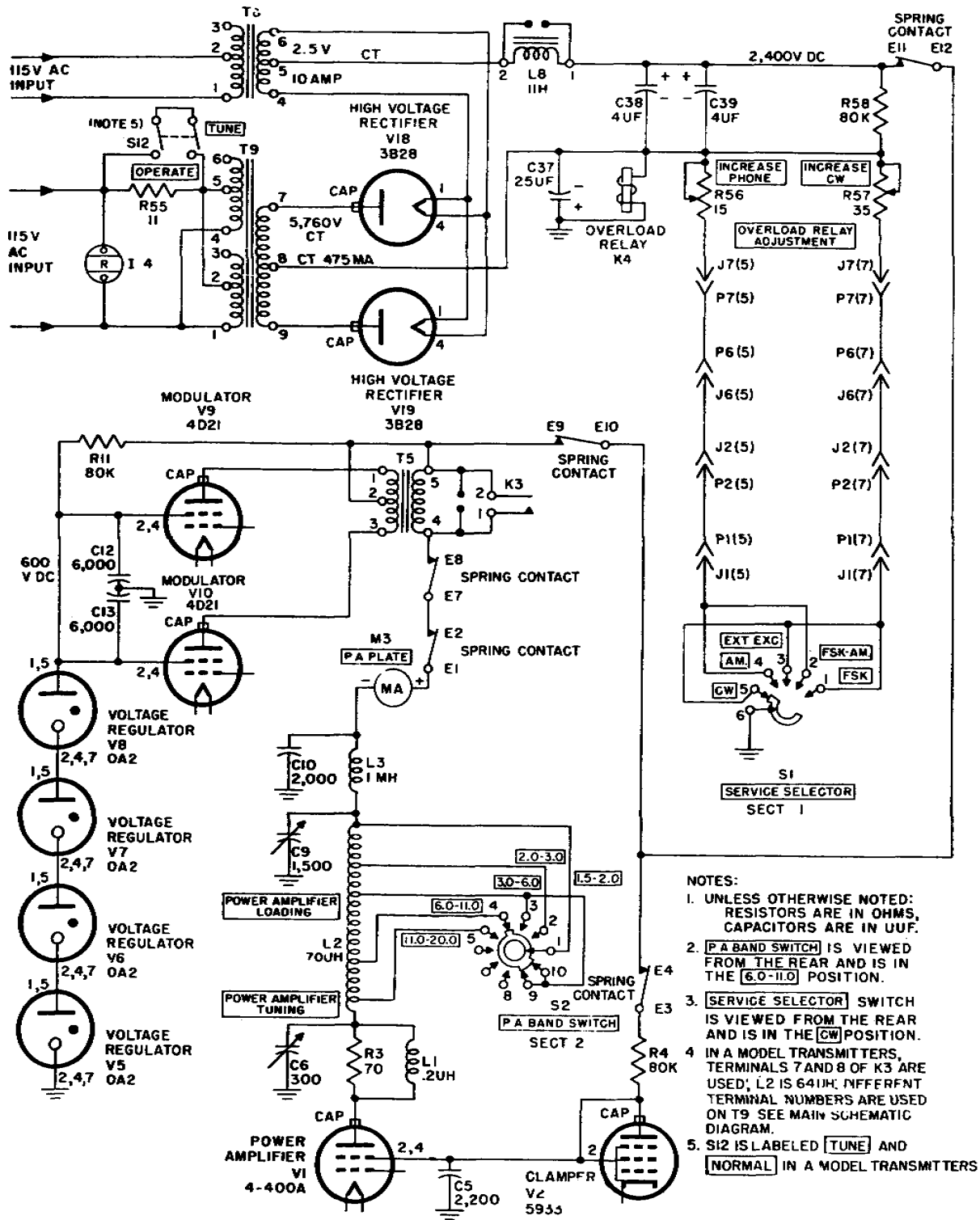

TM809-35-12

Figure 26. High-voltage power supply and distribution, basic and A model transmitters.

AGO 2742A

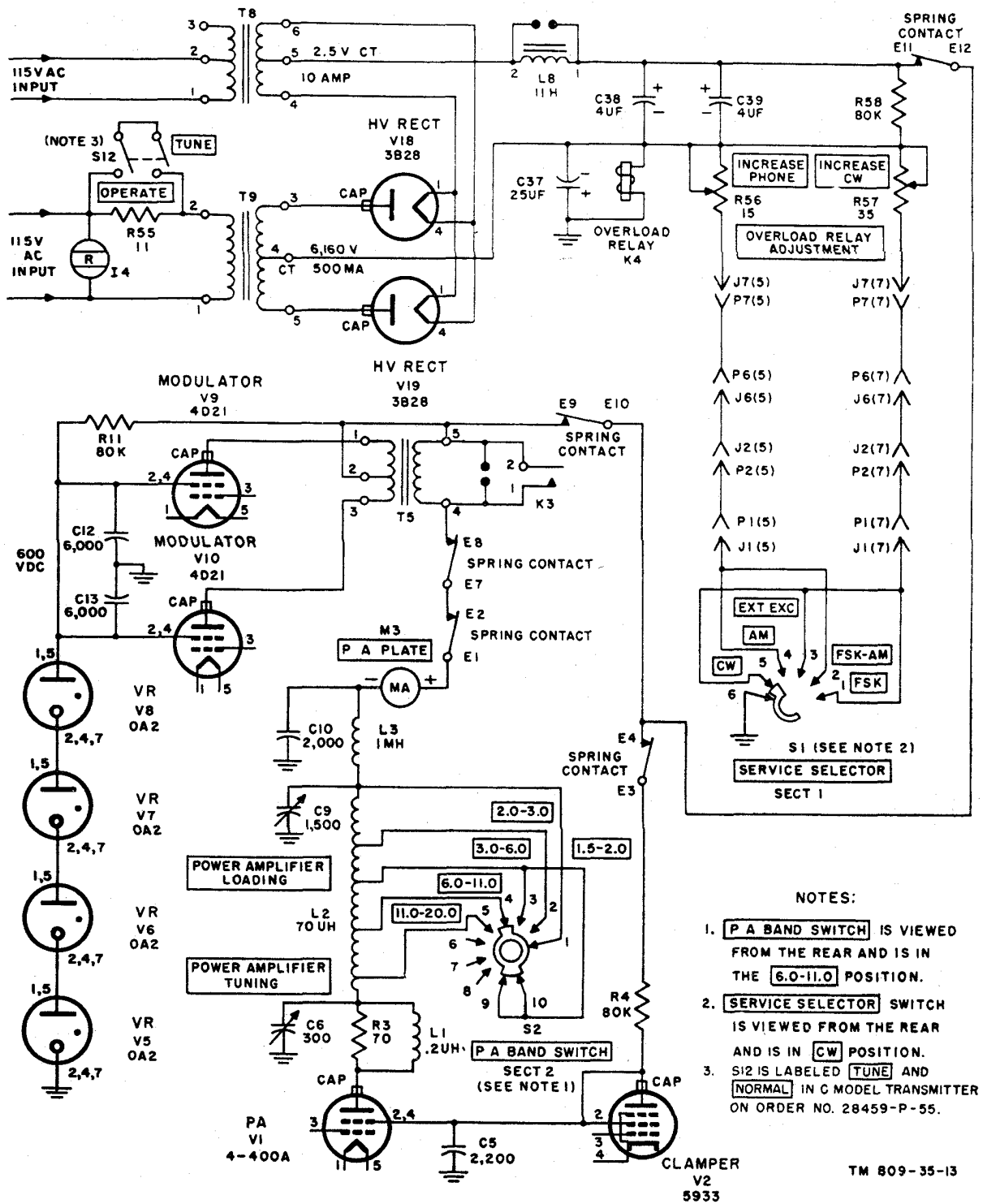

Figure 27. High-voltage power supply and distribution, B and C model transmitters.



L2, and C6 are in the power amplifier tuned pi-network. Capacitor C5 is a screen RF bypass capacitor.

e. The plates of modulators V9 and V10 are supplied through the center-tapped primary of T5. The modulator screens are held at +600 volts by voltage regulators V5 through V8, which form a voltage divider with resistor R11. Capacitors C12 and C13 are screen RF bypasses.

f. The permissible current drain on the high-voltage power supply is set by OVERLOAD RELAY ADJUST-

MENT R56 ( INCREASE PHONE) or R57 (INCREASE CW), as selected by section 1 of SERVICE SELECTOR switch S1. Resistor R56 is switched into the circuit in the AM. and FSK-AM. positions of S1; R57 is used in all other positions of S1. With excessive current flow, the amount of flow through the parallel coil of K4 will rise; when K4 is energized, it operates to break the ac input to T9 and shut off the high voltage. Capacitor C37 prevents TALKING BACK in the overload relay during voice modulation.

### Section III CONTROL AND PROTECTION CIRCUITS

#### 18. Primary Power Distribution and Control Circuits

(figs. 28-30)

Control circuits are provided to enable the operator to apply power to the various stages in a definite sequence and to select the desired mode of operation. Ac line voltage (115 volts) is present at ac input receptacle J14, provided that the power cable is connected to an ac power source.

a. *FILAMENT POWER Circuit Breaker CB1.* When FILAMENT POWER circuit breaker CB1 is thrown to ON, green indicator lamp I 3 lights. Power is immediately available for blower motor B2 and bias transformer T4 through 3 AMP fuse F2 (shunted by BLOWN FUSE INDICATOR I 2) and through switch thermostat S13. The thermostat will operate to open the primary circuit if the ambient temperature exceeds 250° F. The thermostat can be reset only through manual operation of THERMAL RESET switch S13. In the basic model transmitter the bias supply, besides furnishing bias voltages (par. 14), provides dc control voltages for push-to-talk and key relay K2 and slow release relay K1A. In lettered-model transmitters, the bias supply, besides furnishing bias voltages, provides dc control voltages for the keying diode (V20 in the A model; V21 in the B and C models) which in turn controls the keying relay control tube. Closing the FILAMENT POWER circuit breaker also applies power, through 6 AMP fuse F1 (shunted by BLOWN FUSE INDICATOR I 1), to filament transformers T7, T2, T1, and T8 (and, in lettered model transmitters, transformer T10). These primaries are in series with FILAMENT

VOLTAGE control R18. This control provides a manual means of adjusting the filament voltage (from T1 secondary) of the pa tube to its recommended value of 5 to 5.2 volts regardless of line variations; the control adjusts other filaments similarly. In lettered-model transmitters only (figs. 29 and 30), power is also directly applied to exciter plate power transformer T3, and exciter plate power is available when the FILAMENT POWER circuit breaker is operated. In the basic model, the EXCITER PLATE POWER switch (*b* below) must be operated to energize T3. Transformers T7 and T2 supply filaments in the speech amplifier and modulator, respectively; taps on their primaries allow compensation for transmitter wiring voltage drops. Transformer T1 supplies the filaments of the master oscillator (in the basic model transmitter), multiplier, clamper, and power amplifier; it also supplies a control voltage for energizing external excitation relay K101. Transformer T10 (in lettered models only) is a resonant-type regulating transformer which supplies filament voltage to the master oscillator and first buffer tubes V801 and V802. A tap is provided on the resonant winding for 50- or 60-cycle-per-second (cps) operation. For operation on 60 cps, terminals 8 and 9 are tied together; for operation on 50 cps, terminals 9 and 10 are tied together. A dual primary winding is provided and the two windings (1-2 and 3-4) are connected in parallel. Blower motor B1 in the RF deck parallels the primary winding of T1. Transformer T8 supplies the filaments of the high-voltage rectifiers; its primary is connected as an autotransformer, with the voltage developed across termi-

AGO 2742A

nals 3 and 1 used to energize time-delay relay K7 and associated high-voltage circuits (*e* below). This connection allows transformer T8 to act as a protective device for the equipment in that it prevents the application of plate voltage to the high-voltage rectifiers if the primary of T8 fails or if voltage to the primary of T8 is absent.

*b. Switch S6.* Switch S6 is the EXCITER PLATE POWER switch in the basic model transmitter and the KEYING switch in lettered model transmitters. Switch S6 is closed when it is necessary to operate the stages in the exciter strip (V801,V802, V101, V102, V103, and V104) continuously with or without the application of high voltage. This is necessary in FSK, FSK-AM, and EXT EXC operation, because each of these modes uses an uninterrupted RF carrier or a carrier which is keyed externally. The switch normally is left open (EXCITER PLATE POWER switch in OFF position; KEYING switch in NORMAL position) for CW and AM operation. When S6 is closed, contacts 6 and 5 (contacts 6 and 4 in A model transmitters (fig. 29); contacts 3 and 4 in B and C model transmitters (fig. 30)) remove the blocking bias from the grids of V101 and V104. In the basic model transmitter only (fig. 28), contacts 4 and of S6 close the ac input circuit to exciter plate transformer T3, thereby energizing the plate and screen supply for the exciter. Transformer T3 is energized also through contacts 1 and 2 of plate relay K6, which close simultaneously with the application of high voltage as described in *d* below. In all lettered-model transmitters, the exciter power supply is turned on by operation of FILAMENT POWER circuit breaker CB1 (*a* above). With the blocking bias removed by closing S6, the exciter section can be operated *without* applying high voltage to the transmitter. This condition of operation is useful for servicing; it also permits zero-beating the carrier with the receiver or frequency meter for calibration of the transmitter. Contacts 1 and 2 of S6 (contacts 1 and 3 in A model transmitter) insure that the antenna changeover relay (par. 8*b*) will be energized whenever the exciter is made operative in the manner described above this safety feature insures that the antenna is connected when the transmitter is operative.

*c. Time-Delay Circuit.*

- (1) In A model transmitters, terminal numbers of K6, K7, and K8 are different from those in the other models in accordance with the chart

below. The discussion in below uses terminal numbers of the basic model transmitter relays.

Relay	Basic B, and C model terminal numbers	A model terminal numbers
K8	2	4
	1	5
	3	3
	4	7
	5	6
	6	2
	7	1
K7	2	1
	3	6
	7	8,9
	5	3,4
K6	5	2
	6	1
	4	3
	3	4
	1	6
	2	5

- (2) High voltage is applied to the transmitter by a circuit which includes time delay relay K7 (plug-in type) and time-delay slave relay K8. The voltage that appears across terminals 1 and 3 of T8 when the FILAMENT POWER circuit breaker is closed is applied to K7 through normally closed contacts 1 and 2 of K8. After a delay of approximately 25 seconds, K7 is energized, closing contacts 5 and 7. This connects one side of the line to terminal 5 of PLATE: RELAY K6 to energize it, and also energize the coil of K8. With K8 energized, its contacts 1 and 2 open to deenergize K7; contacts 2 and 3 (paralleled by contacts 5 and 4, respectively) close, however, to hold K8 energized and to maintain the connection between one side of the line and terminal 5 of plate relay K6. Even though the deenergizing of K7 causes its contacts 5 and 7 to open, K8 will remain closed. The thermal element of K7 is allowed to cool after it has been

initially heated, to insure a full time delay should power be removed from the equipment and then immediately reapplied.

*d. Plate Relay Circuit.* The manner in which plate relay K6 is energized depends on the type of operation desired. For CW operation, K6 must be energized continuously so that high voltage is always applied to the RF power amplifier tube. If the power amplifier plate voltage were also keyed, key clicks and high-voltage arcing would result. For FSK, FSK-AM, and EXT EXC operation, K6 also must be energized continuously to prevent the externally excited carrier from being interrupted by the removal of plate voltage of the power amplifier tube. Plate relay K6 is energized for the above four types of operation by closing PLATE RELAY switch S10 or by closing a remote control box switch paralleled with S10 through pins C and B of remote control receptacle J12. The circuit from terminal 6 of K6 (terminal 1 of K6 in A model transmitters) to the ac line is completed through microswitch S4 and normally closed contacts 3 and 4 (contacts 5 and 4 in A model transmitters) of overload reset relay K5. Microswitch S4 is normally closed and opened by the P A BAND SWITCH during band switching to prevent arcing across the contacts of POWER AMPLIFIER TUNING switch S2. For AM operation, high voltage can be removed during periods of no transmission to conserve power. PLATE RELAY switch S10 therefore is left open and a parallel circuit is completed. In basic model transmitters, K6 is energized through contacts 6 and 5 of push-to-talk and key relay K2 in series with contacts 6 and 4 (AM position) of section 2 of SERVICE SELECTOR switch S1. In lettered-model transmitters, K6 is energized through contacts of slow release relay K9 (7 and 6 in A model; 6 and 5 in B and C models) and contacts 6 and 4 (AM position of section 2 of SERVICE SELECTOR switch S1. When K6 is energized, contacts connect one side of the ac line to the primary of high-voltage plate transformer T9 through interlocks S11, S5, S7, and S8. In the basic model only, contacts 2 and 1 of K6 complete a circuit for energizing exciter plate transformer-T3, which also may be energized by closing the EXCITER PLATE POWER switch, as described in *b* above.

*e. High-Voltage Circuit.* High-voltage plate transformer T9 receives an ac input as soon as plate relay K6 is energized. The circuit is completed through PLATE POWER circuit breaker CB2, which normally is left in the closed position. Receptacle J13 is provided at the rear of the transmitter to allow the ac input for T9 to be adjusted by a variable autotransformer (not supplied); pins 2 and 3 of J13 normally are jumpered. Indicator lamp I 4 is the plate-power indicator. TUNE-OPERATE switch (TUNENORMAL switch in A and all C models except those procured on Order No. 43056-Phila-56) S12 inserts dropping resistor R55 in series with the primary of T9 when it is placed in the TUNE position.

*f. Antenna Changeover Relay.*

(1) *Basic model transmitter* (fig. 28). Antenna changeover relay K1B connects the RF output of the transmitter to the transmitting antenna during operation. The output is connected from the pa stage through normal open contacts 9 and 10 of K1B. Contact 10 is connected to the internal side of the RF OUTPUT jack, and the antenna is connected to the external side by a coaxial connector. Antenna relay K1B is energized by 115 volts ac during key-down periods of transmission. Until K1B is energized, the RF output line is grounded through R66 and contacts 14 and 13. Antenna relay K1B is energized through contacts 1 and 2 of push-to-talk and key relay (for AM or CW operation) or through contacts 1 and 2 of the EXCITER PLATE POWER switch (for FSK, FSK-AM, or EXT EXC operation). Contacts 3 and 4 of slow release relay K1A, which are also in series with the coil of K1B, are discussed in *g*(1) below.

(2) *Lettered-model transmitters* (figs. 29 and 30). The function of antenna changeover relay K11 (K1 in A model transmitters) is to connect the RF output of the transmitter to the transmitting antenna during operation. The output is connected from the pa stage through normally open contacts 3 and 4. Contact 4 is connected to the in-

ternal side of the RF OUTPUT jack and the antenna is connected to the external side by a coaxial connector. The antenna relay is energized by 115volt ac during key-down periods of transmission. Until the relay is energized, the RF output line from the pa stage is grounded through R66 (R136 in A model transmitter) and contacts 7 and 8. Relay K11 in the B and C models is energized through contacts 3 and 4 of slow-release relay K9 (for AM or CW operation) or through contacts 1 and 2 of the KEYING switch (CONTINUOUS position) for FSK-AM, FSK, or EXT EXC operation. In A model transmitters, antenna changeover relay K1 is energized through contacts 2 and 3 of slow-release relay K9 (for AM or CW operation) or through contacts 1 and 3 of the KEYING switch for FSK-AM, FSK, or EXT EXC operation.

g. *Keying and Slow Release Circuits.*

- (1) *General.* Keying the transmitter involves grounding the blocked grids of second buffer and first amplifier tube V101 and ipa tube V104. In letteredmodel transmitters, and grid circuit of side-tone oscillator V17 is also blockedgrid keyed. Keying is accomplished by depressing the push-to-talk switch on the carbon microphone (AM operation) or by closing the hand key (CW operation), or by closing switch S6 (EXCITER PLATE POWER switch in UP position in basic model; KEYING switch to CONTINUOUS in letteredmodel transmitters ) during EXT EXC, FSK, or FSK-AM. operation. A slow release circuit is incorporated to keep the power amplifier tube loaded, by maintaining the antenna changeover relay in the energized condition, until all radiation has ceased after the hand key or microphone button is released. In the basic model transmitter, slow release relay K1A (fig. 28) and push to-talk and key relay K2 are used. In the lettered-model transmitters, slow release relay K9 and a slow release circuit are used.

(2) *Basic model transmitter (fig. 28).*

- (a) *Slow-release relay K1A.* For AM or CW operation, K1A is energized by -35 volts through section 1 of the SERVICE SELECTOR switch and the microphone button or key. The relay is designed so that the contacts will remain closed for a short period of time (approx.  $1 \pm .2$  sec.) after its power has been removed. This time, however, is not short enough during keying; K1A could not operate antenna changeover relay K1B fast enough to follow the keying action. Therefore, although contacts 3 and 4 of K1A are in series with K1B, K1B is energized through contacts 1 and 2 of push-to-talk and key relay K2; K2 is specifically designed for operation at the required keying speeds. Contacts 4 and 3 of K1A then hold K1B energized for .8 second (minimum) after releasing the button or key which deenergizes the push-to-talk and key relay. Contacts 6 and 5 can be used to complete a disabling relay circuit in a nearby receiver to keep this receiver disabled until all radiation ceases; contact 6 is connected to pin J of remote control receptacle J12. For FSK, FSK-AM, and EXT EXC operation, K1A is energized continuously through section 3 of the SERVICE SELECTOR switch.

- (b) *Push-to-talk and key relay K2.* Push to-talk and key relay K2 is energized by -35 volts from the bias supply and is operated in AM and CW operation only. Relay K2 is energized by grounding its less negative side (terminal 9) through pins F and H of CARBON MICROPHONE jack J11 by pressing the carbon microphone push-to-talk button (for AM operation) or through the closing of a handkey (for CW operation). The microphone may be connected at the remote control box

which is cabled to remote control receptacle J12. Relay K2 then is energized by pressing the microphone button to place pin A of J12 at ground potential. Contacts 1 and 2 key the antenna changeover relay (a) above). Contacts 3 and 4 key the sidetone oscillator (through the CW position of S1, section 4). Contacts 5 and 6 operate the plate relay for AM. operation (through the AM. position of S1, section 2). Contacts 8 and 7 short out the blocking bias applied to the grids of V101 and V104.

- (3) *A Model Transmitters* (fig. 29). During key-up periods capacitor C161 (across cathode and grid of keying relay control tube V21) is charged to a potential equal to the voltage across R130 as determined by the setting of R128. Resistors R129 and R128, in series with resistor R130, form a voltage divider across the -55-volt source. If R128 is set so that 1.5 megohms of its total resistance is in the circuit (neglecting R129), the -55 volts will be divided in half at the junction of R130 and R128 and -27.5 volts will appear across C161. Because the control grid of keying relay control tube V21 is connected to the negative side of C161, this tube is cut off (nonconducting); the coil of plate relay K9 is not energized; and contacts 2-3, 4-5, and 6-7 of K9 remain open. The instant the key is closed, a circuit from the junction of resistors R129, R128, and both plates of keying diode V20 is completed to ground. This allows capacitor C161 to discharge through keying diode V20, effectively shorting resistor R128, and placing the control grid of keying relay control tube V21 at ground potential. Under these conditions, V21 conducts, causing current flow in the coil of relay K9 and closing all contacts of K9. When the keying circuit is opened, -27.5 volts is again applied to the negative side of C161 and the control grid of V21 at a rate determined by the time

constant of R128 and C161. The voltage at the control grid of V21 varies directly with the voltage across C161. When the control grid of V21 reaches a potential of approximately -8 volts, the tube is cut off, current ceases to flow in its plate circuit and relay K9 is deenergized. Capacitor C161 continues to charge until it reaches its maximum steady-state value. Slow release relay K9 therefore remains energized after the keying circuit has been opened, for periods of time varying from zero to several seconds, depending on the setting of R128. Resistor R129 is a current-limiting resistor which isolates the bias voltage supply from variations caused by CW keying. Contacts 6 and 7 operate plate relay K6 for AM operation through SERVICE SELECTOR switch S1, section 2. Contacts 4 and 5 can be used to complete a disabling relay circuit in a nearby receiver to keep the receiver disabled until all radiation ceases; contact 5 is connected to pin J of remote control receptacle J12. Contacts 2 and 3 of relay K9 operate antenna changeover relay K1. Contacts 1 and 3 of the KEYING switch parallel contacts 2 and 3 of slow release relay K9 when S6 is in the CONTINUOUS position. This prevents loss of ac power to the coil of K1 in the event of failure of K9 or V21.

- (4) *B and C Model Transmitters* (fig. 30). During key-up periods, capacitor C48 (across cathode and grid of keying relay control V22) is charged to a potential equal to the voltage across R69 as determined by the setting of R74. Resistors R68 and R74, in series with resistor R69, form a voltage divider across the 50-volt source. If R74 is set so that 1.5 megohms of its total resistance is in the circuit (neglecting R68), the -50 volts will be divided in half at the junction of R69 and R74 and -25 volts will appear across C48. Because the control grid of keying re-

AGO 2742A

lay control tube V22 is connected to the negative side of C48, this tube is cut off (nonconducting); the coil of plate relay K9 is not energized; and contacts 3-4, 5-6, and 7-8 of K9 remain open. The instant the key is closed, a circuit from the junction of resistors R68, R74, and both plates of keying diode V21 is completed to ground. This allows capacitor C48 to discharge through keying diode V21, effectively shorting resistor R74 and placing the control grid of keying relay control tube V22 at ground potential. Under these conditions, V22 conducts, causing current flow in the coil of relay K9 and closing all contacts of K9. When the keying circuit is opened, -25 volts is again applied to the negative side of C48 and to the control grid of V22 at a rate determined by the time constant of R74 and C48. The voltage at the control grid of V22 varies directly with the voltage across C48. When the control grid of V22 reaches a potential of approximately -8 volts, the tube is cut off, current ceases to flow in its plate circuit, and relay K9 is deenergized. Capacitor C48 continues to charge until it reaches its maximum steady state value. Slow release relay K9 therefore remains energized after the keying circuit has been opened, for periods of time varying from zero to several seconds, depending on the setting of R74. Resistor R68 is a current limiting resistor which isolates the bias voltage supply from variations caused by CW keying. Contacts 5 and 6 operate plate relay K6 for AM operation through SERVICE SELECTOR switch S1, section 2. Contacts 7 and 8 can be used to complete a disabling relay circuit in a nearby receiver to keep the receiver disabled until all radiation ceases; contact 6 is connected to pin J of remote control receptacle J12. Contacts 3 and 4 of relay K9 operate antenna changeover relay K11. Terminals 1 and 2 of S6 parallel contacts 3 and 4 of slow release relay K9

when S6 is in the CONTINUOUS position. This prevents the loss of ac power to the coil of K11 in the event of failure of V22 or relay K9.

*h. CW-Phone Relay K3.* CW-phone relay K3 disables the modulator when it is in the deenergized (CW) condition. The relay is energized from the ac line when in the FSK-AM or AM position. When energized, contacts 1 and 2 (contacts 7 and 8 in A model transmitters) open to remove the short from the modulation transformer secondary, and contacts 5 and 6 (contacts 3 and 4 in A model transmitters) close, remove cutoff bias, and provide the modulator with operating bias.

*i. External Excitation Relay K101.* External excitation relay K101 is energized when the SERVICE SELECTOR switch is in the EXT EXC position by 26.5 volts ac from T1. In the unenergized condition (FSK, FSK-AM, AM, and CW), contacts 1 and 2 ground the cathode of ipa tube V104. The RF output from one of the multipliers is connected to the ipa grid through contacts 4 and 5. In the energized condition (EXT EXC), the direct ground at the V104 cathode is removed and R121 serves as the cathode resistor. Contacts 5 and 6 connect the external excitation signal from EXT EXC jack J104 to the input of V104.

*j. SERVICE SELECTOR Switch S1 in Basic Model Transmitter.* SERVICE SELECTOR switch S1 is a 5 position 4 deck rotary switch. Switch sections have been discussed individually throughout this chapter. The functions of the entire switch are grouped as follows:

- (1) *Section 1 (contacts 1-6).* In the FSK, EXT EXC, and CW positions of section 1 (contacts 1, 3, and 5), OVERLOAD RELAY ADJUSTMENT R57 ( INCREASE CW) is placed across overload relay K4 (par. 17f). In the FSK-AM and AM positions (contacts 2 and 4), R57 is replaced by OVERLOAD RELAY ADJUSTMENT R56 (INCREASE PHONE).
- (2) *Section 1 (contacts 7-12).* The AM and CW positions of section 1 (contacts 10 and 11) connect slow release relay K1A in parallel to K2 and allow

it to be energized by pressing the microphone button or closing the hand key. The other positions are not used.

- (3) *Section 2 (contacts 1-6)*. The AM position of section 2 (contact 4) allows plate relay K6 to be energized by pushing the microphone button; push-to talk and key relay K2 is energized, closing its contacts 5 and 6, which together with S1, bypass PLATE RELAY switch S10. In the CW position (contact 5), K2 no longer bypasses S10. Therefore, for CW operation, S10 must be closed to operate K6. This prevents K6 from following the keying action of K2.
  - (4) *Section 2 (contacts 7-12)* . In the FSK-AM, and AM positions of section 2 (contacts 8 and 10), CW-phone relay K3 is energized to make the modulator stage operable. Relay K3 is deenergized in all other positions.
  - (5) *Section 3 (contacts 1-6)*. The FSK, FSK-AM, and EXT EXC positions of section 4(contacts 1, 2, and 3) complete the circuit for energizing the slow release relay continuously (*g(2)(a)* above) .
  - (6) *Section 3 (contacts 7-12)*. In the EXT EXC position of section 3 (contact 9), external excitation relay K101 is energized ( *i* above). Relay K101 is deenergized in all other positions.
  - (7) *Section 4 (contacts 1-6)*. The CW position of section 4 (contact 5), in series with contacts 4 and 3 of the push-to-talk and key relay, completes the cathode circuit of the sidetone oscillator. The sidetone oscillator is inoperative in all other positions.
  - (8) *Section 4 (contacts 7-12)*. Section 4 feeds operating voltages for the master oscillator and first buffer through its AM and CW positions (contacts 10 and 11). These stages are inoperative in all other positions.
- k. *SERVICE SELECTOR Switch in A Model Transmitters* (fig. 29). The functions of switch S1 in Radio Transmitter T-368/URT are as follows:

- (1) *Section 1 (contacts 1-6)*. In the FSK, EXT EXC, and CW positions, OVERLOAD RELAY ADJUSTMENT R57 (INCREASE CW) is placed across overload relay K4 (par. 17f). In the FSK-AM and AM positions, OVERLOAD RELAY ADJUSTMENT R56 (INCREASE PHONE) is placed across overload relay K4.
- (2) *Section 1 (contacts 7-12)* . In the FSK, FSK-AM, AM, and CW positions, the cathode of protective relay control tube V23 is grounded. This allows V23 to conduct if excitation input is lost (par. 7a). This energizes a protective circuit for intermediate power amplifier V104. In the EXT EXC position, the protective circuit is inoperative.
- (3) *Section 2 (contacts 1-6)*. The FSK, FSK-AM, EXT EXC, and AM positions complete a path to energize plate relay K6 (when slow release relay K9 is energized) and bypass PLATE RELAY switch S10. In the CW position, S10 can only be bypassed by completing another bypass circuit through remote control receptacle J12. When no outside control is used, S10 must be used to energize K6 for CW operation.
- (4) *Section 2 (contacts 7-12)* . In the FSK A M, and AM positions, a path to energize CW-phone relay K3 is provided. Operation of K3 makes modulation possible. Relay K3 is deenergized in all other positions.
- (5) *Section 3 (contacts 1-6)*. Placing switch S1 in EXT EXC position (contacts 3 and 6) removes cutoff bias from V17, V101, and V104 and keys the transmitter continuously.
- (6) *Section 3 (contacts 7-12)* . In the EXT EXC position, external excitation relay K101 is energized. Relay K101 is deenergized in all other positions.
- (7) *Section 4 (contacts 1-6)*. In the CW position, the cathode of sidetone oscillator V17 is grounded to enable V17 to oscillate when grid bias is removed during key-down condition. In all other positions, the cathode circuit is open

and the sidetone oscillator will not operate.

- (8) *Section 4 (contacts 7-12)* . Plate and screen voltage circuits to the master oscillator and first buffer stages are completed in the AM and CW positions. The master oscillator and first buffer are inoperative in all other positions.

*1. SERVICE SELECTOR Switch S1 in B and C Model Transmitters ( fig. 30 ) .*

- (1) *Section 1 (contacts 1-6)*. In the FSK, EXT EXC, and CW positions of section 1 (contacts 1, 3, and 5), OVERLOAD RELAY ADJUSTMENT R57 (INCREASE CW) is placed in parallel to the coil of overload relay K4 (par. 17f). In the FSK-AM and AM positions (contacts 2 and 4), R57 is replaced by OVERLOAD RELAY ADJUSTMENT R56 (INCREASE PHONE) .
- (2) *Section 1 (contacts 7-12)*. Section 1 connects B+ voltage to the master oscillator and first buffer stages in the AM, CW, FSK, and FSK-AM positions (contacts 7, 8, 10 and 11). These stages are inoperative in the EXT EXC position.
- (3) *Section 2 (contacts 1-6)*. The AM position of section 2 (contact 4) allows plate relay K6 to be energized by pushing the microphone button; relay K9 is energized, closing its contacts 5 and 6, which, together with S1, bypass PLATE RELAY switch S10. Because the transmitter is keyed continuously in the FSK, FSK-AM, and EXT EXC positions, contacts 5 and 6 of relay K9 remain closed and PLATE RELAY switch S10 is bypassed. In the CW position (contact 5), contacts 5 and 6 of relay K9 no longer bypass S10, and S10 can only be bypassed by completing another bypass circuit through remote control receptacle J12. When no outside control is used, S10 must be used to energize K6 for CW operation. In C model transmitters, there is no connection at terminal 3. As in the CW

position, S10 is not bypassed in the EXT EXC position and plate relay K6 must be energized by closing S10 or completing a remote circuit through J12.

- (4) *Section 3 (contacts 7-12)*. In the FSK-AM and AM positions of section 2 (contacts 8 and 10), the cod; circuit nit of CW-phone relay K3 is energized to allow the modulator stage to operate (h above). Relay K3 is deenergized in all other positions.
- (5) *Section 3(contacts 1-6)*. The CW position of section 3 (contact 5) completes the cathode circuit of sidetone oscillator V17 to ground. The sidetone oscillator is inoperative in all other positions.
- (6) *Sections (contacts 7-12)*. In the EXT EXC position of section 3 (contact 9), external excitation relay K101 is energized ( i above). Relay K101 is deenergized in all other positions.
- (7) *Section 4 (contacts 1-6)*. The CW, AM, FSK and FSK-AM positions of section 4 (contacts 1, 2, 4, and 5) complete the cathode circuit of protective relay control V23 to ground. The protective relay control is inoperative in the EXT EXC position (contact 3) (par. 7a).
- (8) *Section 4 (contacts 7-12)*. The EXT EXC position of section 4 (contact 9) completes the keying line circuit to ground. The ground is removed in all other positions.

## **19. Overload Protection Circuits**

(figs. 28-30)

The high-voltage power supply is protected against overloads by relay K4. Relay K4 is energized when the current drain from the supply exceeds 425 milliamperes (ma) or 550 ma, depending on the type of operation used. When K4 is energized, contacts 4, 3, 1, and 2 (3, 4, 6, 7 in A model transmitters) complete a circuit for energizing overload reset relay K5, which is in series with OVERLOAD RESET switch S9. Contacts 3 and 4 of K5 (4 and 5 of K5 in A model transmitters) then open to break the K6 plate relay circuit and thus remove the ac input to high-voltage transformer T9.



to high-voltage transformer T9. Contacts 1 and 2 of K5 (6 and 7 of K5 in A model transmitters) are holding contacts which keep K5 energized even after no power supply current is available for energizing K4. Thus, once K4 is energized, high voltage can be restored only by momentarily opening OVERLOAD RESET switch S9 to deenergize K5. Relay K5 will remain deenergized

when S9 is released to its normal closed position only if the overload was temporary; otherwise, K4 will be energized again as soon as high voltage is applied and will in turn reenergize K5. Overloads are indicated by zero readings on the P A PLATE meter and PLATE POWER indicator I 4, which will go out whenever the ac input is removed from T9.

## Section IV. MECHANICAL ANALYSIS OF TRANSMITTER

### 20. Oscillator-Multiplier Tuning Drive Mechanism

(fig. 31)

The master oscillator, multiplier, and intermediate amplifier stages of the transmitter are tuned by the movement of powdered iron cores (permeability tuning) in inductor L801 and in the inductors in tank circuits Z101 through Z110. Movement of the cores is controlled by cams (except for the core in L801) that are turned through gearing by the TUNING CONTROL knob on the front panel. Band switching is accomplished by turning switch S101 through gearing from the BAND SELECTOR knob. The gearing is designed so that after alignment of individual circuit elements, direct and accurate frequency indications can be obtained from front panel counters.

*a.* The band switching mechanism includes the BAND SELECTOR knob, a detent, a 60-tooth band switch drive gear meshing with a 60-tooth bandswitch idler gear, a flexible coupling, and the wafers of S101. Frequencies in the selected band are indicated through windows in each of four counter shutters. The shutters are mounted on the shafts of four gears driven by a shutter rack gear. The rack gear is moved vertically by a slotted lever arm which engages the rack pin. The lever arm is operated by a cam on the band switch drive shaft. As the BAND SELECTOR is turned clockwise through each of its detent positions, the lever arm (spring-loaded) moves upward so that the cylindrical shutters are rotated downward. The four counter windows are so positioned on the shutters that only the counter which contains frequencies in the selected band will be exposed. The three counters not being used are masked by solid portions of their shutters.

*b.* The powdered iron cores of the inductors in the multiplier tank circuits are mounted on a rack which is raised and lowered by two cams and two cam followers. The camshaft is driven by a 184-tooth exciter camshaft gear through a flexible coupling. The camshaft gear is driven from the TUNING CONTROL knob through a 27-tooth exciter drive gear, a 108-tooth exciter drive idler gear, and a 46-tooth exciter drive idler gear pinion. The powdered iron cores can be individually raised or lowered from the top of the rack for alignment purposes. Master oscillator tuning inductor L801 is located inside the sealed master oscillator assembly. The core of L801 is tuned by the tuning control through a 114-tooth oscillator drive gear, a 114-tooth oscillator drive shaft gear, and additional parts inside the sealed assembly. The frequency counters are driven by the tuning control through a counter drive gear, a counter drive idler gear pinion, meshing counterdrive idler gears, and meshing bevel gears. All four counters are driven simultaneously through additional gearing as shown in the box insert of figure 31.

### 21. Power Amplifier Tuning Drive Mechanism

(fig. 32)

The tuning drive mechanism for the power amplifier consists of two separate sections, one for loading and one for tuning.

*a.* The loading mechanism is manually operated by the POWER AMPLIFIER LOADING control knob. The turning of the control adjusts loading capacitor C9 which is on the same shaft. A mechanical counter is controlled through bevel gears, and registers the position (setting) of the control. Positive stop action to prevent movement past a given number of turns is provided. A typical stop is shown in exploded view in the figure. As the level gear on the stop shaft rotates, the stop collar

AGO 2742A

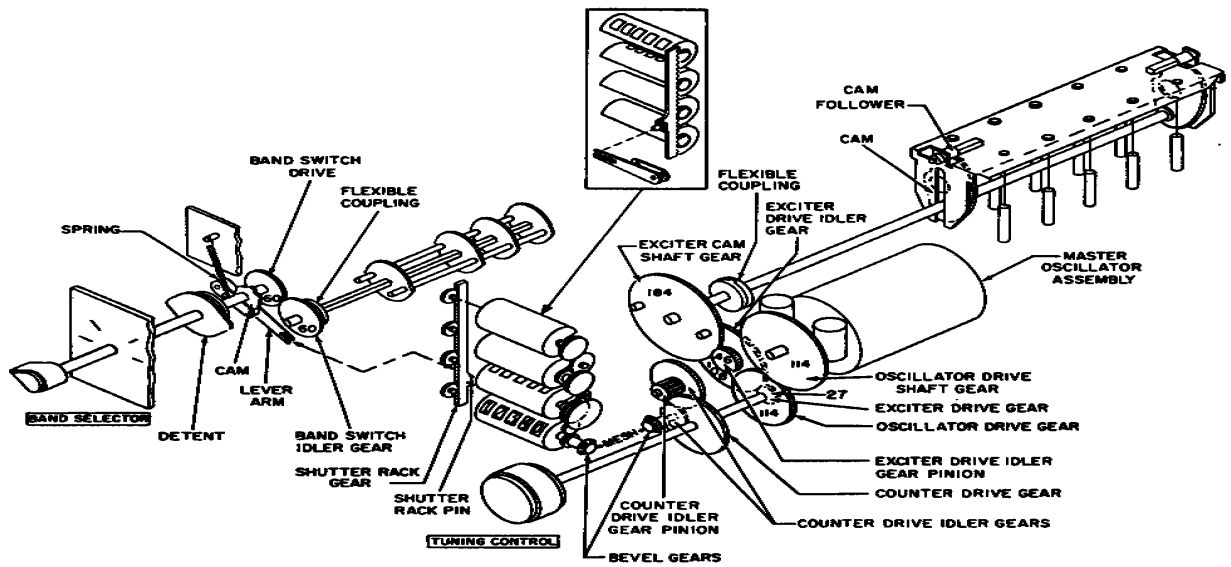

Figure 31 Oscillator-multiplier tuning drive mechanism, functional diagram.

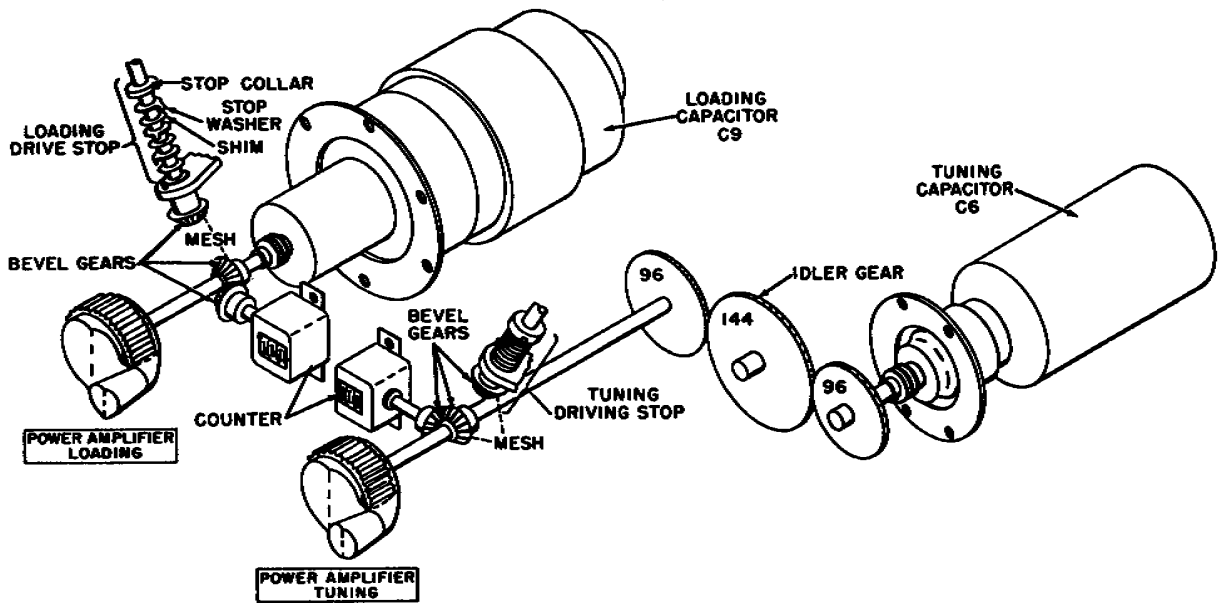

Figure 32. Power amplifier tuning drive mechanism, functional diagram.

TM 809-26

rotates the adjacent Stop washer The projection on the washer turns freely until it engages the washer below. This action is repeated until the bottom washer is stopped by a projection on the casting The control is now restrained from any further movement.

b. The tuning mechanism is manually operated by the POWER AMPLIFIER TUNING

control knob. This mechanism is identical with the loading mechanism described above except that the tuning capacitor (C6) is driven by a gear train instead of directly by the control shaft. The control shaft is connected to the capacitor through three gears having 96, 144, and 96 teeth, respectively. As before, a mechanical counter indicates the setting, and a stop prevents rotation beyond a designated number of turns.

## Section V. ANTENNA TUNING UNIT

### 22. General

(fig. 33)

The antenna tuning unit is used to match the impedance of the transmitting antenna to that of the transmitter RF output circuit. The tuning unit is so designed that the transmitter will operate satisfactorily with a 5-section rod antenna or with a long-wire auxiliary antenna over a frequency range of 2.0 to 20 mc.

### 23. Antenna Tuning Unit Theory

a. Figure 34 is a functional schematic diagram of the tuning unit with range switch SW9 (SW9.1 and SW9.2) set to 2-10 M-C and a whip antenna connected to the unit. Since the antenna is electrically much shorter than a quarter wave length, it presents a highly capacitive load to

b.

the transmitter. This capacitive antenna is tuned to resonance by providing added inductance of low-frequency loading coil L6 through the variable tap controlled by the FREQUENCY (10 MC-INCREASE-2 MC) crank handle control. When the inductive reactance of L6 is made equal to the capacitive reactance of the whip antenna, the load presented to the transmitter is purely resistive. Coupling coil L5 acts as an impedance matching transformer so that the resistance of the antenna, as reflected back to the pa tank circuit, presents the optimum plate load resistance as viewed from the pa tube plate. Rotating the COUPLING INCREASE control handle varies the movable tap of L5 and changes the impedance ratio.

b. Figure 35 is a functional schematic diagram of the tuning unit with range switch SW9

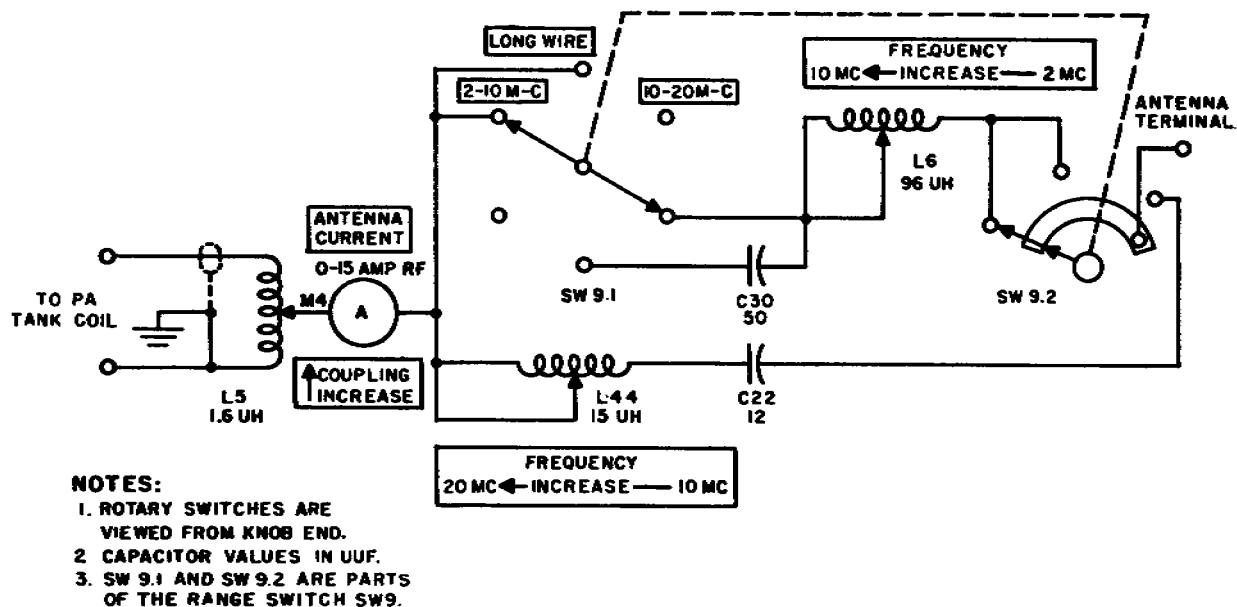

TM 809-98

Figure 33. Antenna Tuning Unit BC-939-B, schematic diagram

set to 10-26; mc and a whip antenna connected to the unit. From 10 to 12.5 mc, the reactance of the antenna is capacitive; from 12.5 to 20 mc the reactance is inductive. At approximately 12.5 mc the antenna is purely resistive. The antenna is tuned to resonance by varying the movable tap of high-frequency loading coil L44 by the FREQUENCY (20 MC-INCREASE-10 MC) crank handle control. Vacuum-type capacitor C22 provides the added capacitance necessary when operating from 12.5 to 20 mc. Its effect is neutralized when operating from 10 to 12.5 mc by including more turns of coil L44 in the circuit.

c. Figure 36 is a functional schematic diagram of the tuning unit with switch SW9 set to LONG WIRE and a long-wire antenna connected to the unit. The antenna may be either capacitive or inductive depending on the length of the wire and frequency used. The net reactance is made equal to zero by varying the movable tap of low-frequency loading coil L6. Vacuum-type capacitor C30 provides the necessary capital capacitance when the reactance of the antenna is inductive because

of antenna wire length and operating frequency. ANTENNA CURRENT meter M4 indicates RF current flowing in the series circuit of the antenna and antenna loading circuit. RF current is maximum when the antenna is tuned to resonance with the transmitter frequency by the antenna loading circuits in the tuning unit.

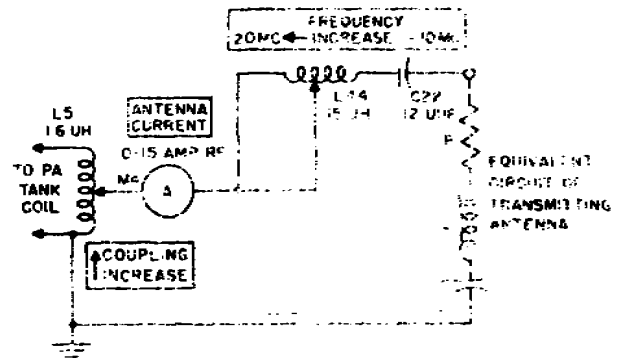

Figure 35. Antenna tuning unit with range switch in 10-20 M-C position.

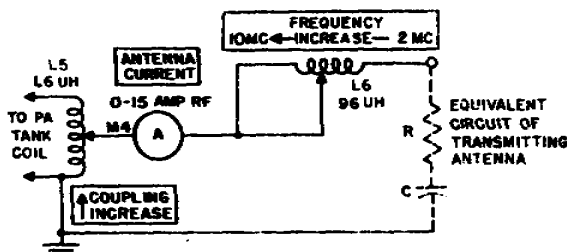

Figure 34. Antenna tuning unit with range switch in 2-10, M-C position.

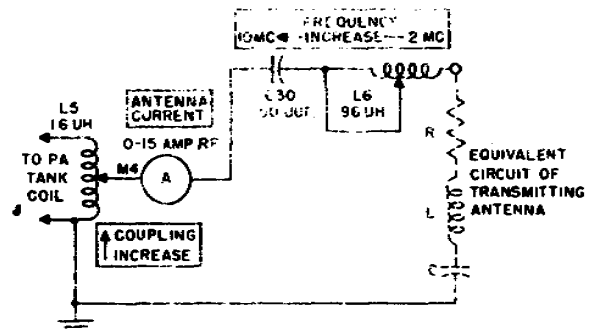

Figure 36. Antenna tuning unit with range switch in LONG WIRE position.

## CHAPTER 2

### TROUBLESHOOTING

---

**Warning:** Radio Transmitter T-368(\*)/URT develops extremely high voltages which are dangerous to life if contacted. The protective electrical interlock switches should not be relied upon. Be sure that the back cover and the three decks are closed before applying plate power. A red pilot lamp labeled PLATE POWER, on the front panel of the transmitter, indicates when the high voltage supply is turned on. Since this lamp may burn out, do not rely upon it to show that no high voltage is present. When the transmitter is in operation, extremely high rf voltages are present around the tuning unit. Make sure that the voltage is off and use the shorting stick (Test, Prod, stock No. 3F3705-12.19) before changing parts and making repairs.

#### 24. General Instructions

Troubleshooting at field and depot maintenance level includes all the techniques outlined for organizational maintenance and any special or additional techniques required to isolate a defective part. The field and depot maintenance procedures are not complete in themselves but supplement the procedures described in TM 11-809-20. The systematic troubleshooting procedure, which begins with the operational and sectionalization checks that can be performed at the organizational level, must be completed by means of sectionalizing, localizing, and isolating techniques.

#### 25. Troubleshooting Procedures

*a. General.* The first step in servicing a defective transmitter is to sectionalize the fault. Sectionalization means tracing the fault to a major component or circuit responsible for the abnormal operation of the transmitter. The second step is to localize the fault. Localization means tracing the fault to the defective part responsible for the abnormal condition. Some faults, such as burned-out resistors, arcing, and shorted transformers, often can be located by sight, smell, and hearing. The majority of faults, however, must be localized by checking voltages and resistances or by signal substitution.

*b. Component Sectionalization and Localization.* Listed below is a group of tests arranged to simplify and reduce unnecessary work and to aid in tracing a trouble

to a specific component. The simpler tests are used first; those that follow are more complex. For example, the trouble is traced to a section of the transmitter (a deck, or a subassembly on a deck), and the faulty component in that section is located; then the trouble is remedied. The service procedure is summarized as follows:

- (1) *Visual inspection.* The purpose of visual inspection is to enable the repairman to locate faults without testing or measuring circuits. All meter readings or other visual signs should be observed. This inspection is valuable in avoiding additional damage that might occur through improper servicing methods and in forestalling future failures.
- (2) *Resistance measurements.* The use of resistance measurements to locate trouble will prevent further damage to the equipment if possible short circuits are present. To assist in the localization of such faults, troubleshooting data include the normal resistance values as measured at the tube sockets and at key terminal points. The normal resistance values at any point can be determined by referring to the resistance values shown in diagrams or by the use of the resistor color code (fig. 37). Before making any resistance measurements turn off the power.

- (3) *Voltage measurements.* Voltage measurements are an almost indispensable aid to the repairman, because most troubles either result from abnormal voltage or produce abnormal voltages. Normal voltages at tube sockets and key terminal points are shown on figures listed in paragraph 26. Compare readings taken with normal readings shown.
- (4) *Operational test.* The operational test is performed by connecting the transmitter for normal operation and following the procedures of the equipment performance checklist given in TM 11-809-20. It is important because it frequently indicates the general location of trouble. In many instances, the information gained will determine the exact nature of the fault. To utilize this information fully, interpret all symptoms in relation to one another.
- (5) *Troubleshooting chart.* The trouble symptoms listed in the troubleshooting chart (par. 31) will aid greatly in localizing trouble.
- (6) *Signal substitution.* Signal substitution (par. 34) is effective in localizing trouble by use of proper signal generators.
- (7) *Stage-gain chart.* The stage-gain chart (par. 35) helps to localize obscure troubles in the speech amplifier section of the transmitter.
- (8) *Intermittents.* In all these tests, the possibility of intermittent conditions should not be overlooked. If present, this type of trouble often may be made to appear by tapping or jarring the equipment. It is possible that some external connection may cause the trouble. Gently move the wiring to check for loose connections, and tap the components with an insulated tool such as a fiber rod. This may show where a faulty connection or component is located.

## 26. Troubleshooting Data

Always check the circuit labels, because the schematic diagram in the manual may not include circuit changes made during equipment production. Take advantage of the material supplied in this manual, and in TM 11-809-20 where the equipment performance checklist and tube location diagrams are given. Consult the troubleshooting data in the chart below.

Description	Fig. No.
RF deck:	
Top views	39-41, 4 of TM 11-809-20
Bottom views	42-45
Blower duct, cover removed	46, 47
Oscillator and multiplier subassembly.	48
Multiplier subassembly views	49-52
Modulator deck:	
Top views	60-63
Bottom views	64-68
Speech amplifier	69-71
Power supply deck:	
Top view	83
Bottom view	84
Relay assembly, cover removed	85
Housing, interior view, decks removed	87, 88
Voltage and resistance measurements:	
Oscillator subassembly tubes	53
Multiplier subassembly tubes	54
Other RF deck tubes	55
J1 and J8, basic model	56
J1 and J8, lettered models	57
RF deck terminal bracket	58
Multiplier subassembly terminal boards.	59
Speech amplifier tubes, basic, B and C models.	72
Speech amplifier tubes, A model	73
Speech amplifier terminal boards basic, B. and C models.	74
Speech amplifier terminal boards, A model.	75
Modulator deck:	
Basic model	76
A model	77
B and C models	78
J2 and J6, basic model	79
J2 and J6, lettered models	80
Terminal board TB4	81
CARBON MICROPHONE jack J11	82
Power supply deck	86
J12	89

## RESISTOR COLOR CODE (MIL-STD RESISTORS)

### AXIAL-LEAD RESISTORS (INSULATED)

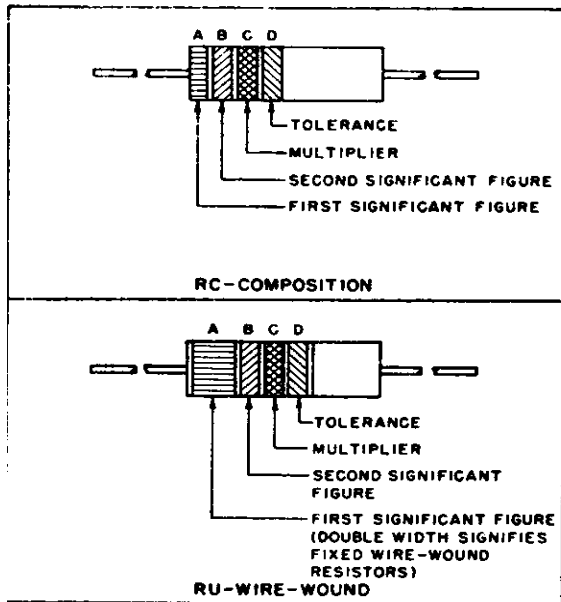

### RADIAL-LEAD RESISTORS (UNINSULATED)

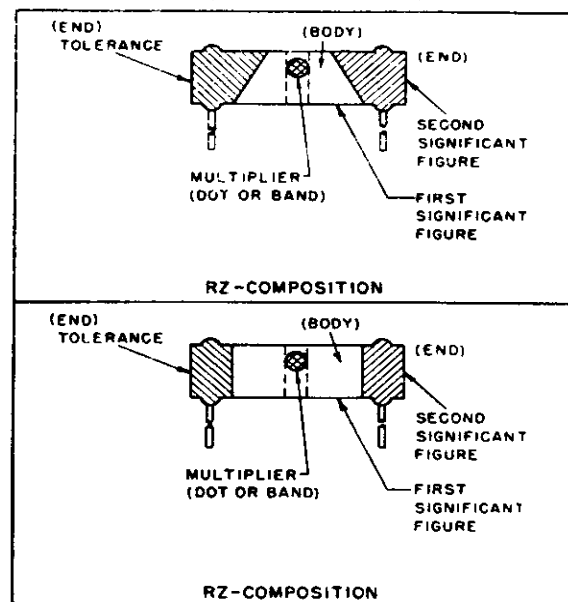

## RESISTOR COLOR CODE

BAND A OR BODY*		BAND B OR END*		BAND C OR DOT OR BAND*		BAND D OR END*	
COLOR	FIRST SIGNIFICANT FIGURE	COLOR	SECOND SIGNIFICANT FIGURE	COLOR	MULTIPLIER	COLOR	RESISTANCE TOLERANCE (PERCENT)
BLACK	0	BLACK	0	BLACK	1	BODY	$\pm 20$
BROWN	1	BROWN	1	BROWN	10	SILVER	$\pm 10$
RED	2	RED	2	RED	100	GOLD	$\pm 5$
ORANGE	3	ORANGE	3	ORANGE	1,000		
YELLOW	4	YELLOW	4	YELLOW	10,000		
GREEN	5	GREEN	5	GREEN	100,000		
BLUE	6	BLUE	6	BLUE	1,000,000		
PURPLE (VIOLET)	7	PURPLE (VIOLET)	7				
GRAY	8	GRAY	8	GOLD	0.1		
WHITE	9	WHITE	9	SILVER	0.01		

\*FOR WIRE-WOUND-TYPE RESISTORS, BAND A SHALL BE DOUBLE-WIDTH. WHEN BODY COLOR IS THE SAME AS THE DOT (OR BAND) OR END COLOR, THE COLORS ARE DIFFERENTIATED BY SHADE, GLOSS, OR OTHER MEANS.

**EXAMPLES (BAND MARKING)**

10 OHMS  $\pm 20$  PERCENT: BROWN BAND A; BLACK BAND B; BLACK BAND C; NO BAND D.  
 4.7 OHMS  $\pm 5$  PERCENT: YELLOW BAND A; PURPLE BAND B; GOLD BAND C; GOLD BAND D.

**EXAMPLES (BODY MARKING):**

10 OHMS  $\pm 20$  PERCENT: BROWN BODY; BLACK END; BLACK DOT OR BAND; BODY COLOR ON TOLERANCE END.  
 3,000 OHMS  $\pm 10$  PERCENT: ORANGE BODY; BLACK END, RED DOT OR BAND; SILVER END

Figure 37. MIL STD resistor color codes.

## CAPACITOR COLOR CODE MARKING (MIL-STD CAPACITORS)

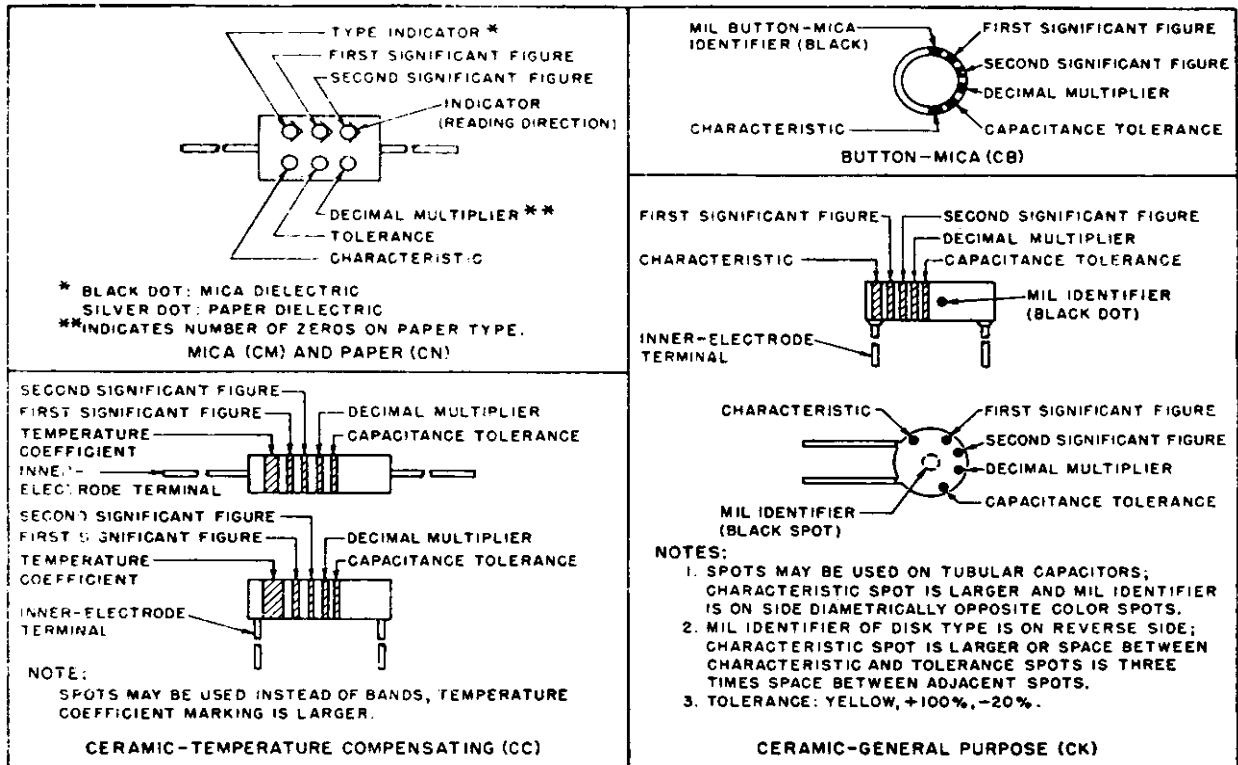

### CAPACITOR COLOR CODE

COLOR	SIG FIG.	MULTIPLIER		CHARACTERISTIC <sup>1</sup>				TOLERANCE <sup>2</sup>					TEMPERATURE COEFFICIENT (UUF/UF/°C)
		DECIMAL	NUMBER OF ZEROS	CM	CN	CB	CK	CM	CN	CB	CC		
											OVER 10UUF	10UUF OR LESS	
BLACK	0	1	NONE		A			20	20	20	20	2	ZERO
BROWN	1	10	1	B	E	B	W				1		-30
RED	2	100	2	C	H		X	2		2	2		-80
ORANGE	3	1,000	3	D	J	D			30				-150
YELLOW	4	10,000	4	E	P								-220
GREEN	5		5	F	R						5	0.5	-330
BLUE	6		6		S								-470
PURPLE (VIOLET)	7		7		T	W							-750
GRAY	8		8			X						0.25	+30
WHITE	9		9								10	1	-330(±500) <sup>3</sup>
GOLD		0.1						5		5			+100
SILVER		0.01						10	10	10			

1. LETTERS ARE IN TYPE DESIGNATIONS GIVEN IN MIL-C SPECIFICATIONS.
2. IN PERCENT, EXCEPT IN UUF FOR CC-TYPE CAPACITORS OF 10 UUF OR LESS.
3. INTENDED FOR USE IN CIRCUITS NOT REQUIRING COMPENSATION.

STD-C1

Figure 38. MIL STD capacitor color codes.



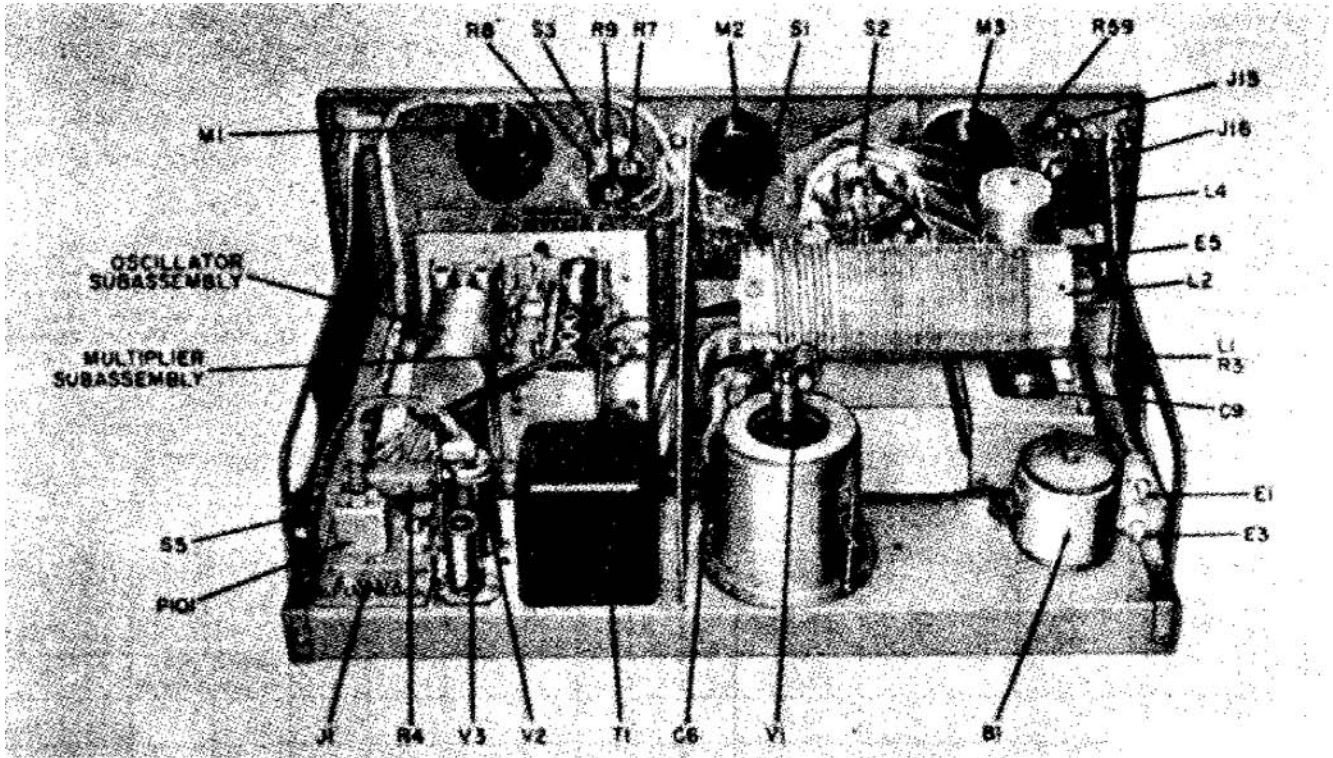

Figure 39. RF deck of basic model transmitter, top view.

TM 809-36

AGO 2742A

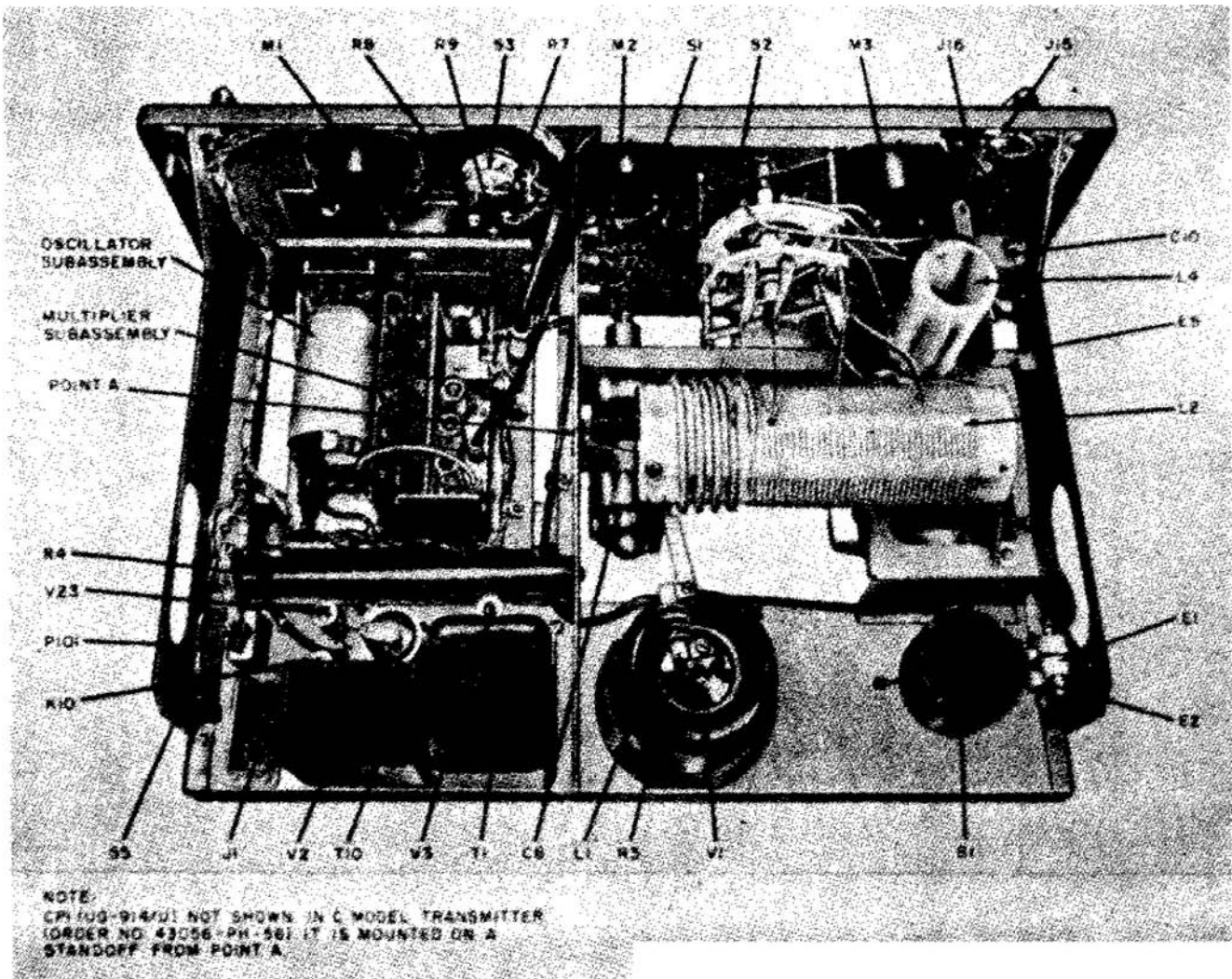

Figure 40. RF deck of B model transmitters and C model transmitters procured on Order No. 43056-Phila-56, top view.

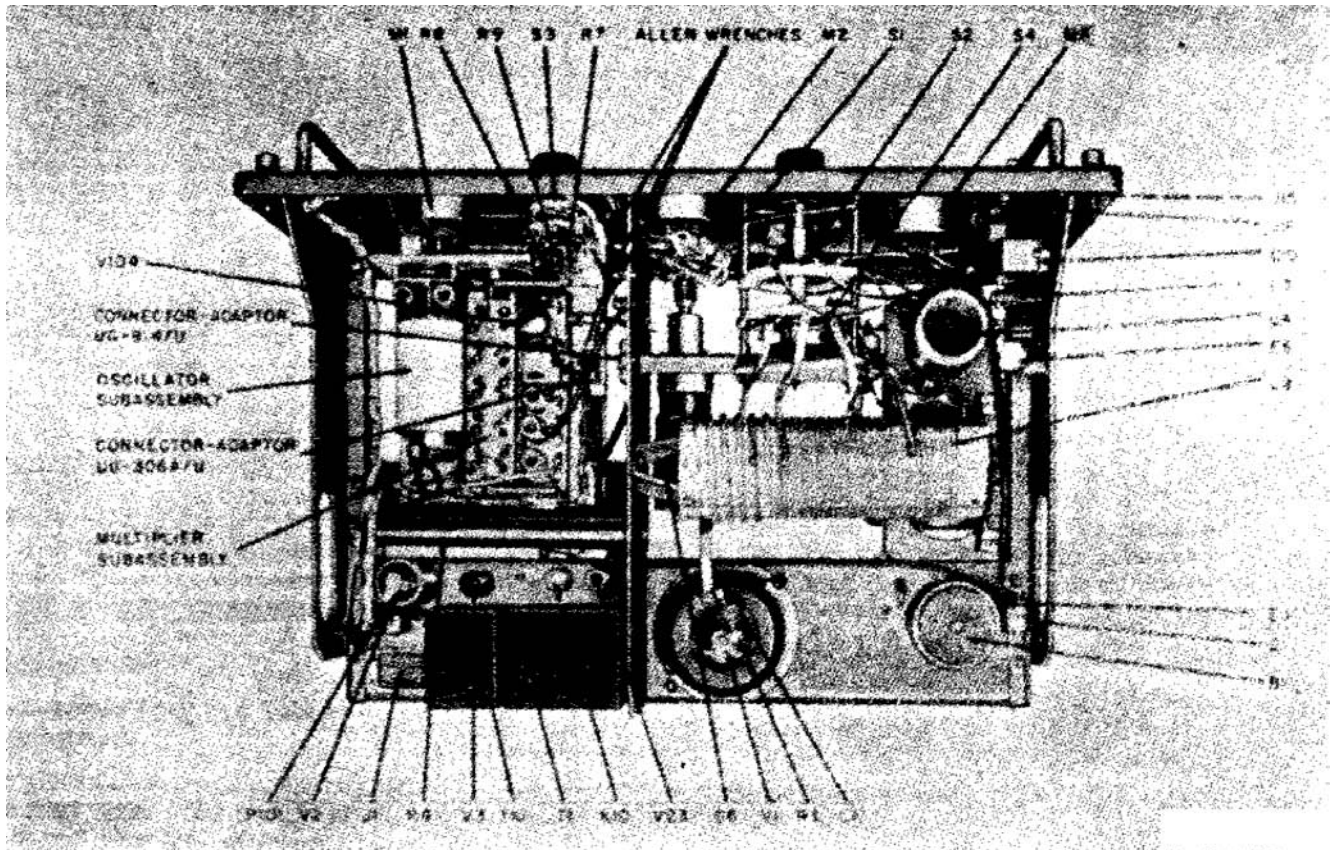

Figure 41. RF deck of C model transmitters procured in Order No 28459-Phila-55, top view.

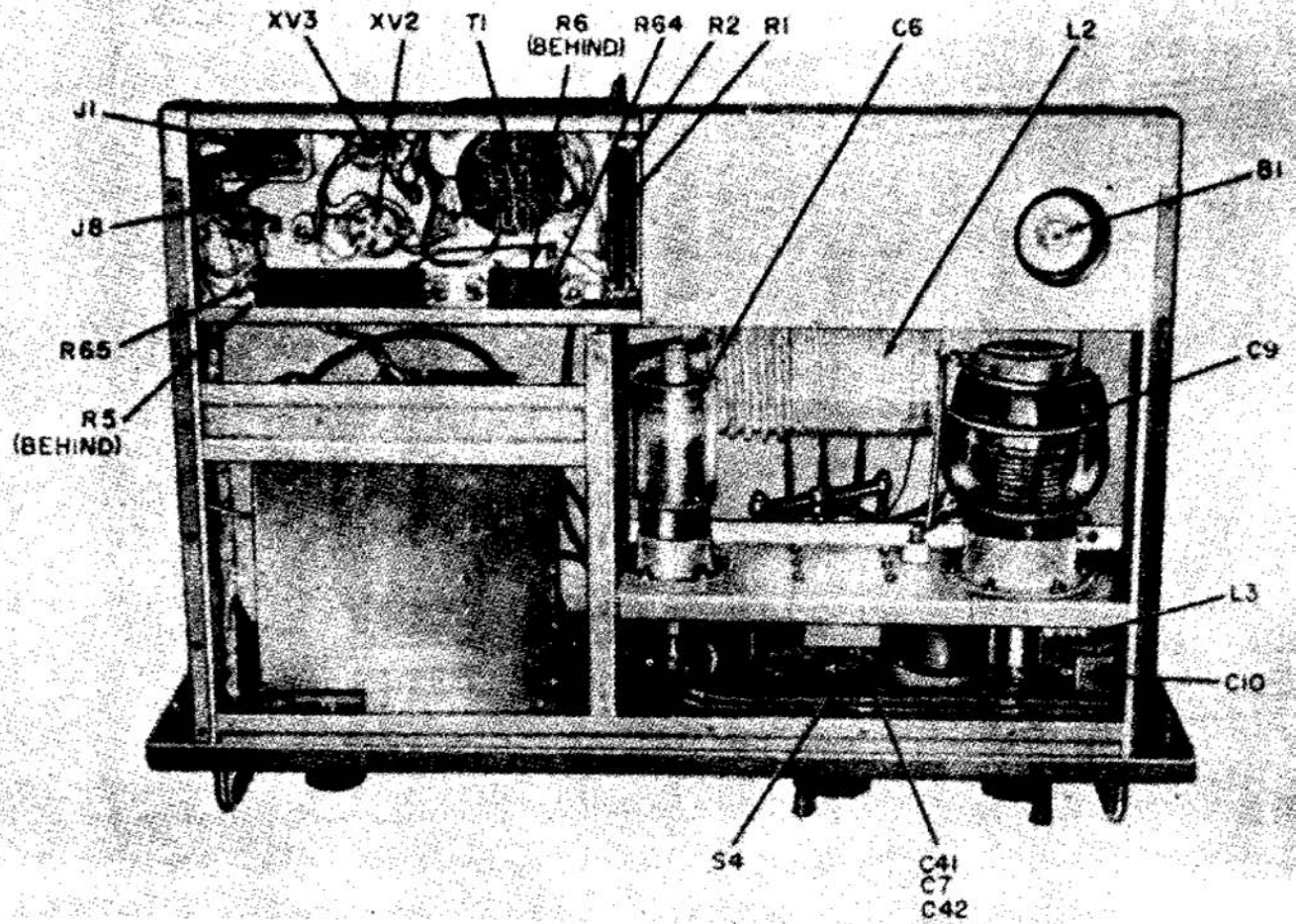
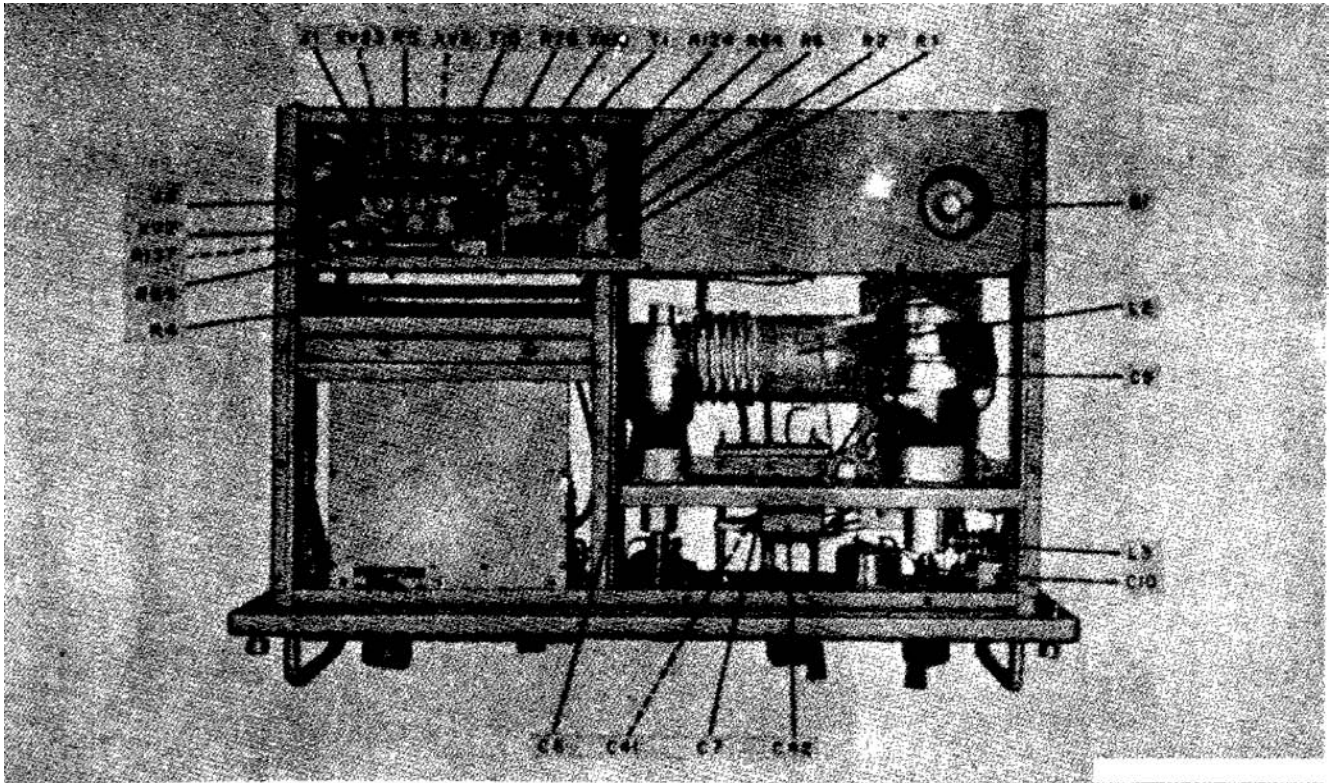

Figure 42. RF deck of basic model transmitter, bottom view.





TM809-C4-29

Figure 43. RF deck of A model transmitters, bottom view.

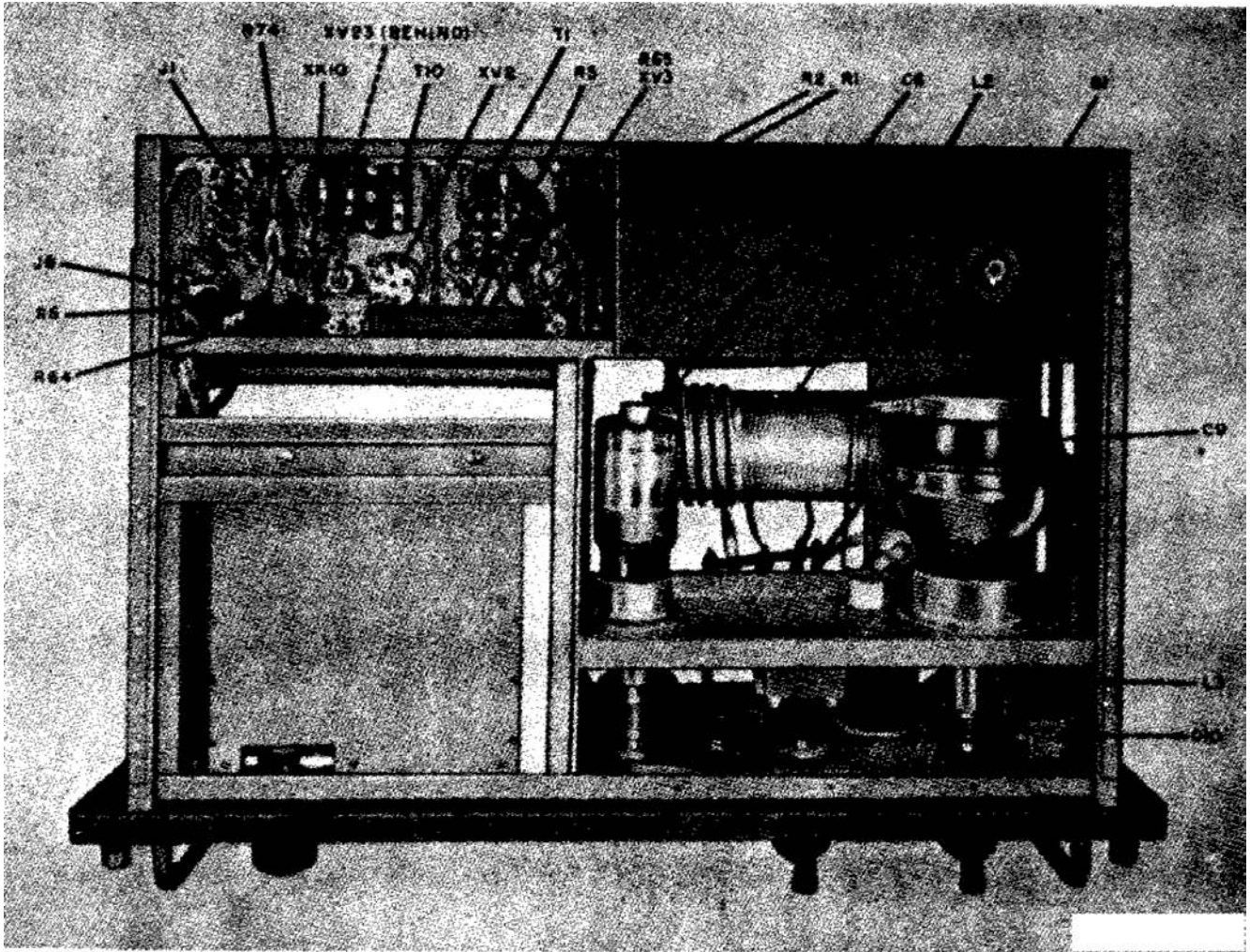

Figure 44. RF deck of B model transmitters and C model transmitters procured on Order No. 43056-Phila-56, bottom view.

AGO 2742A

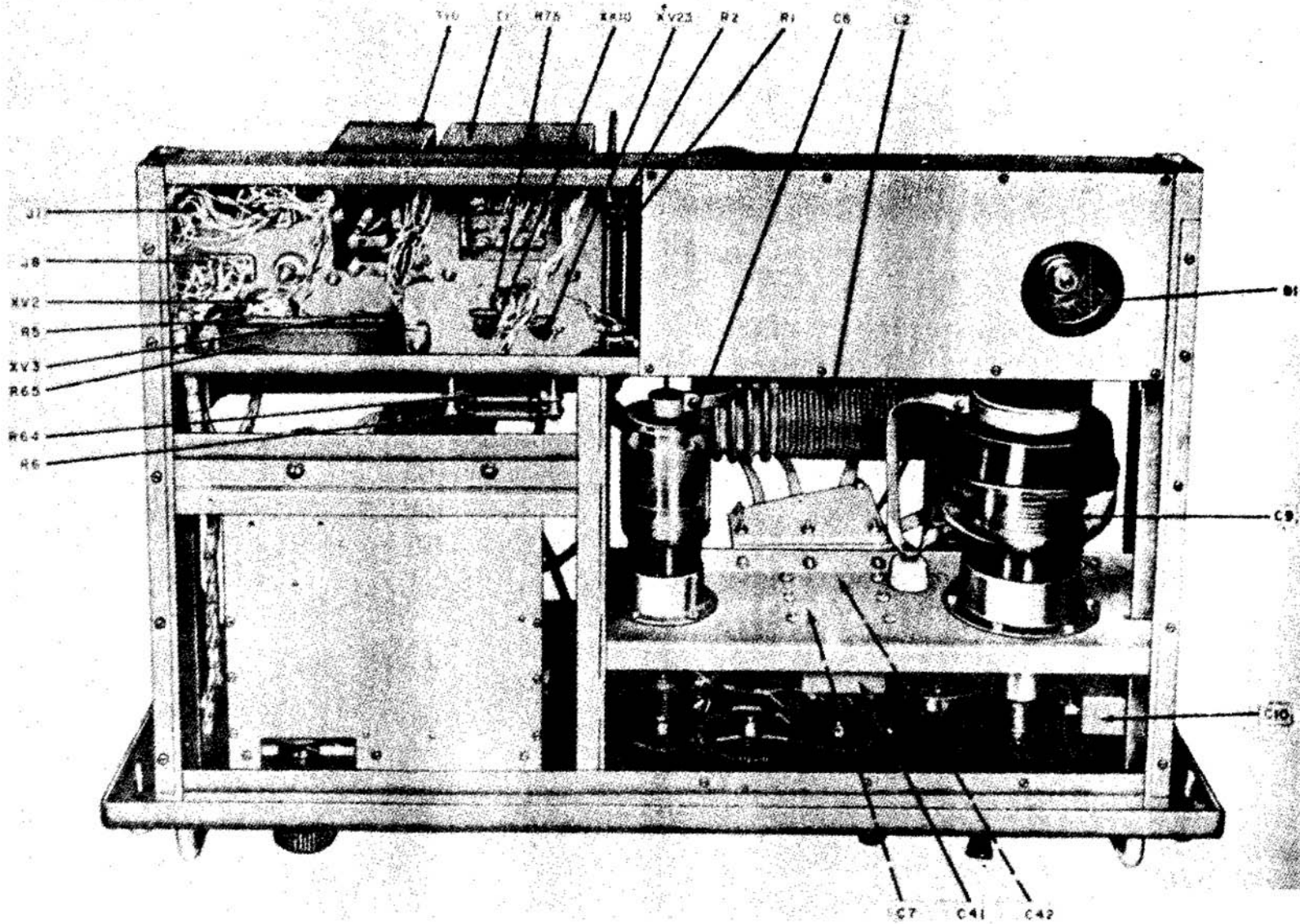
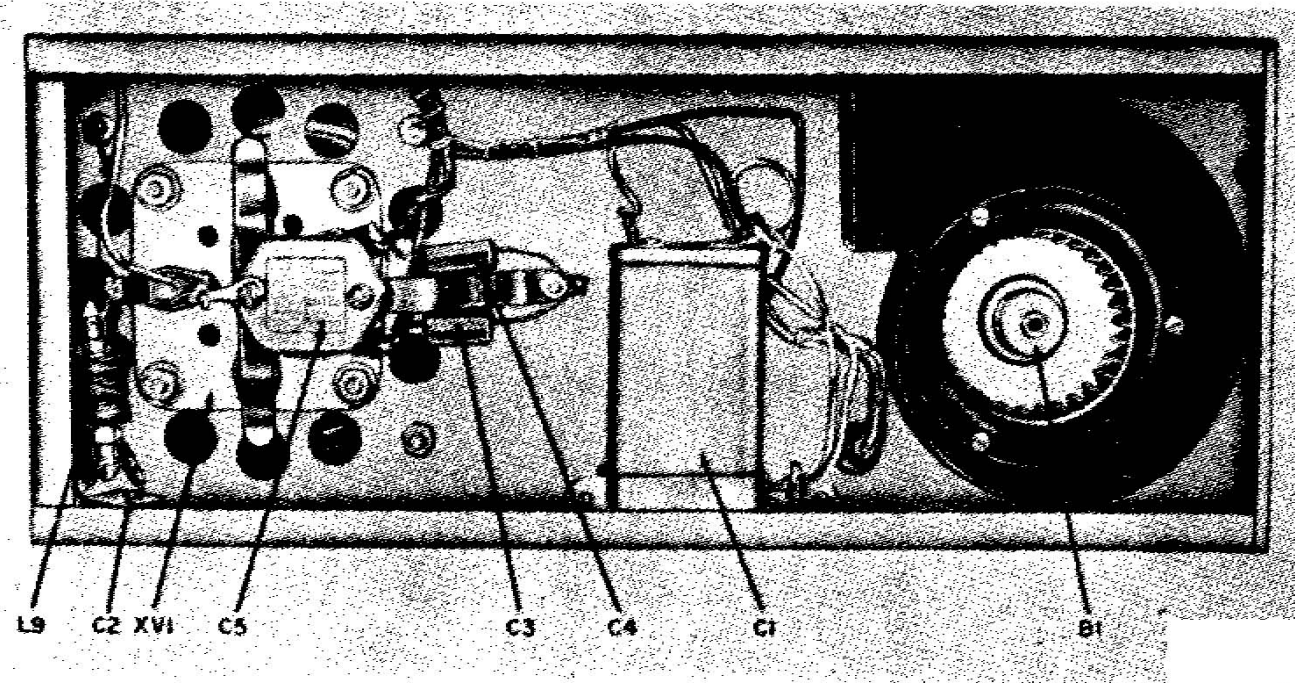

Figure 45. RF deck of C model transmitters, bottom view.

TM809-C2-16



TM 809-17

Figure 46. RF deck, blower duct (cover removed), all model transmitters except A.



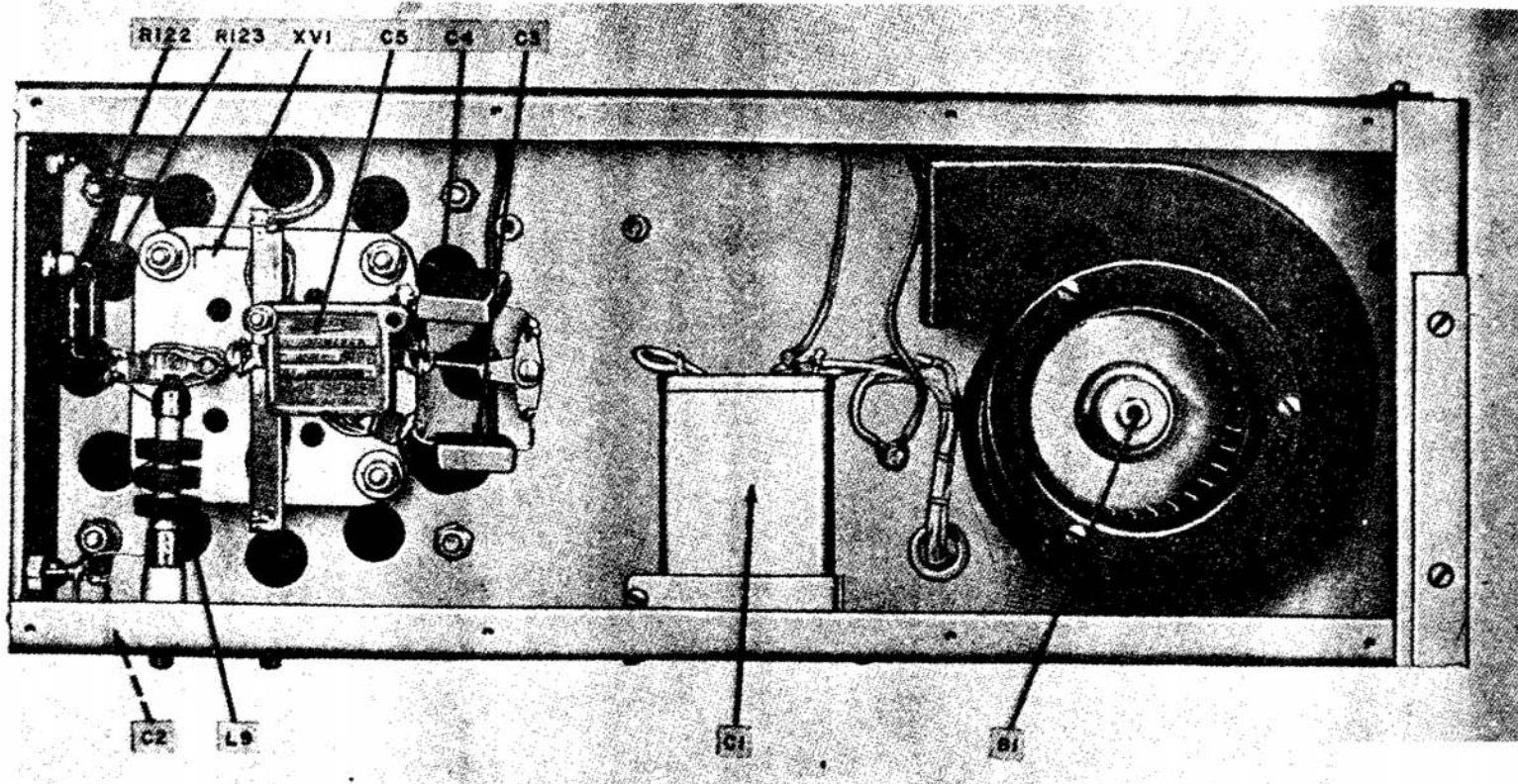
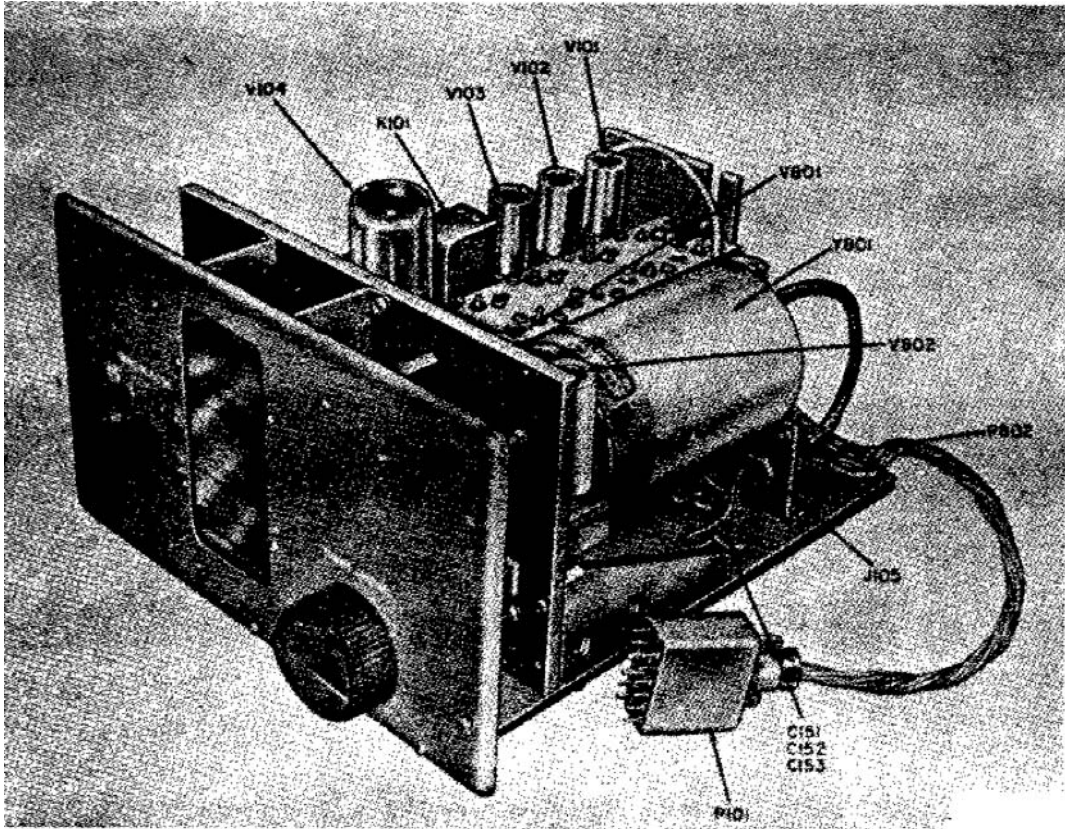

Figure 47. RF deck, blower duct (cover removed), A model transmitters.

TM809-C4-17



TM809-38

Figure 48. Oscillator and multiplier subassembly, top view.

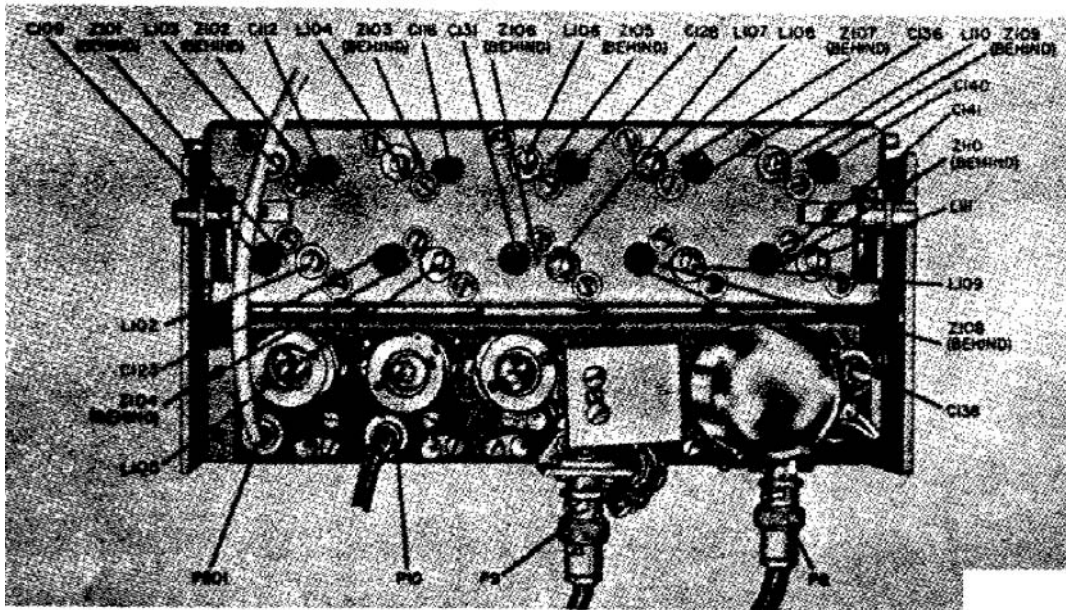

TM809-65

Figure 49. Multiplier subassembly, top view.

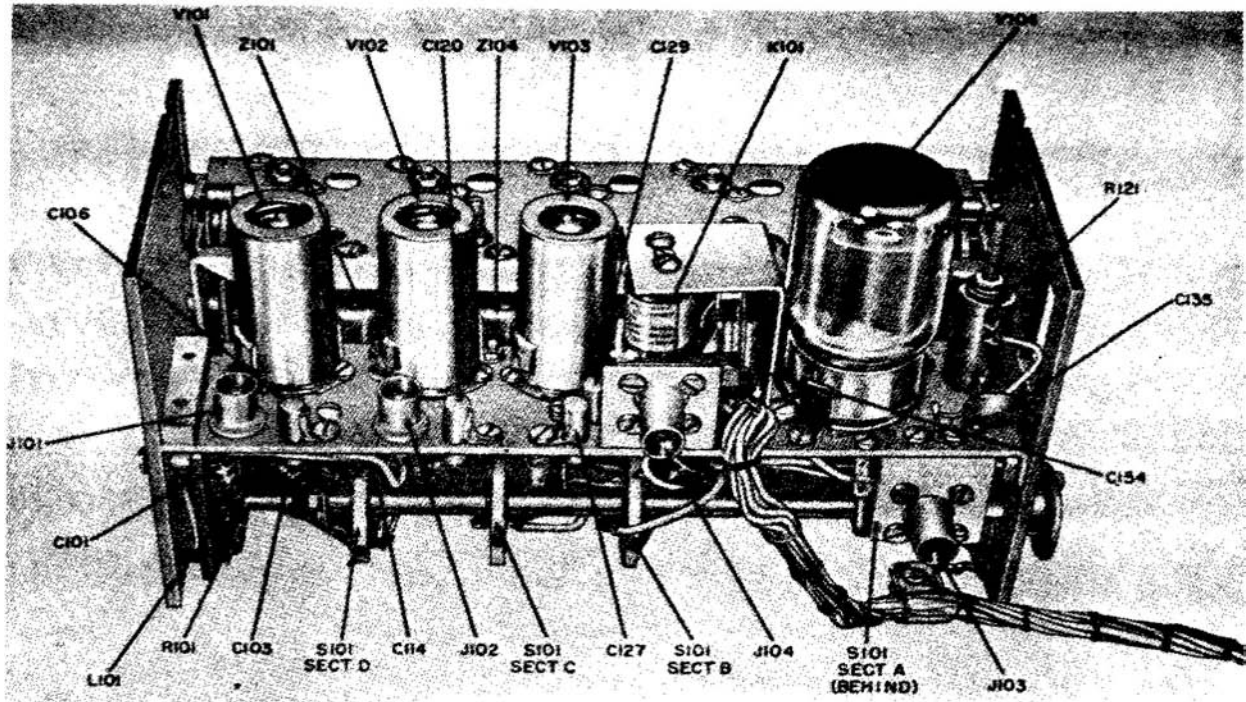

TM 809-39

Figure 50. Multiplier subassembly, side view.

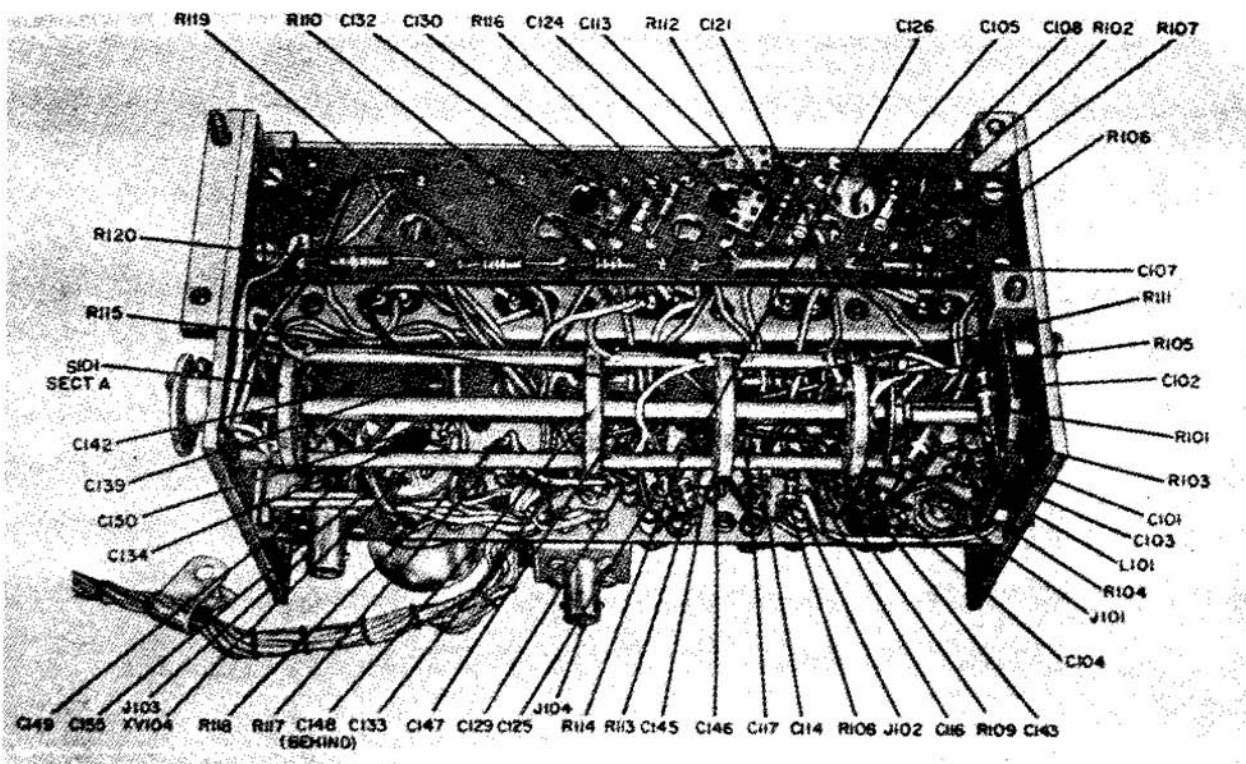

TM 809-40

Figure 51. Multiplier subassembly in basic model, bottom view.

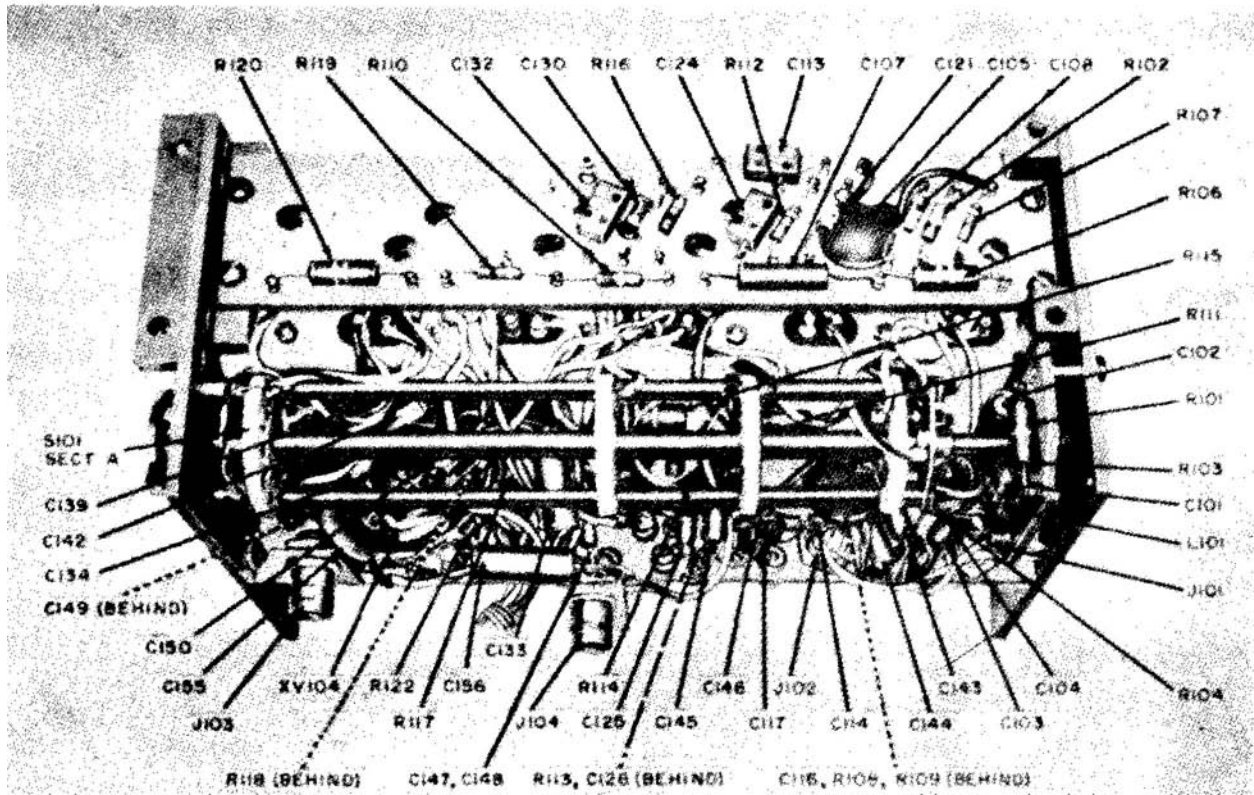

TM 809-C1-3

Figure 52. Bottom view of multiplier subassembly in lettered-model transmitters.

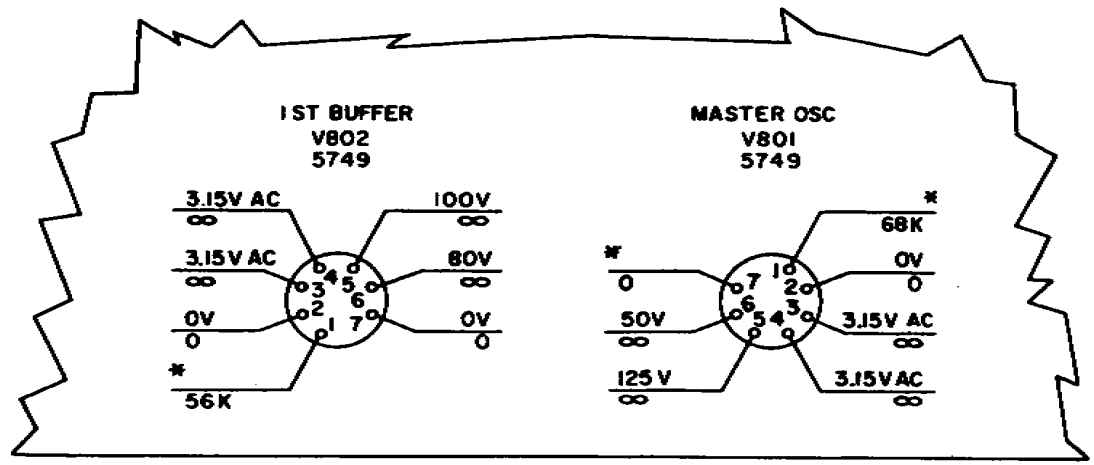

- NOTES:
1. 115V AC INPUT TO POWER SOCKET [J14].
  2. [SERVICE SELECTOR] SWITCH AT [CW] OR [AM].
  3. VOLTAGE AND RESISTANCES MEASURED TO GROUND WITH 20,000 OHMS-PER-VOLT METER.
  4. RESISTANCES MEASURED WITH P802 DISCONNECTED.
  5. \* INDICATES PINS AT WHICH VOLTAGE MEASUREMENTS WOULD BE MISLEADING BECAUSE OF CIRCUIT UNBALANCE.
  6. VOLTAGE READINGS ABOVE LINE, RESISTANCE READINGS BELOW LINE.

TM 809-48

Figure 53. Oscillator subassembly, V801 and V802, voltage and resistance data.



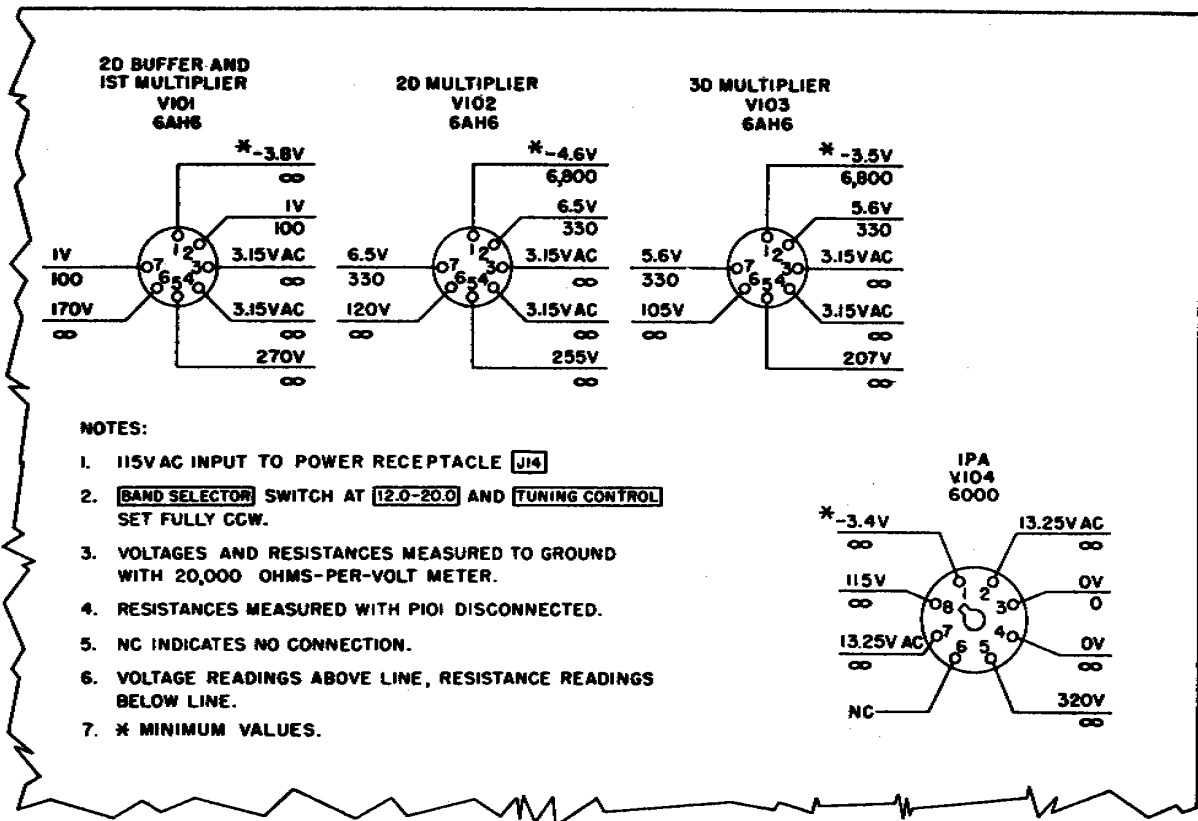

TM 809-50

Figure 54. Multiplier subassembly, V101 through V104, voltage and resistance data.

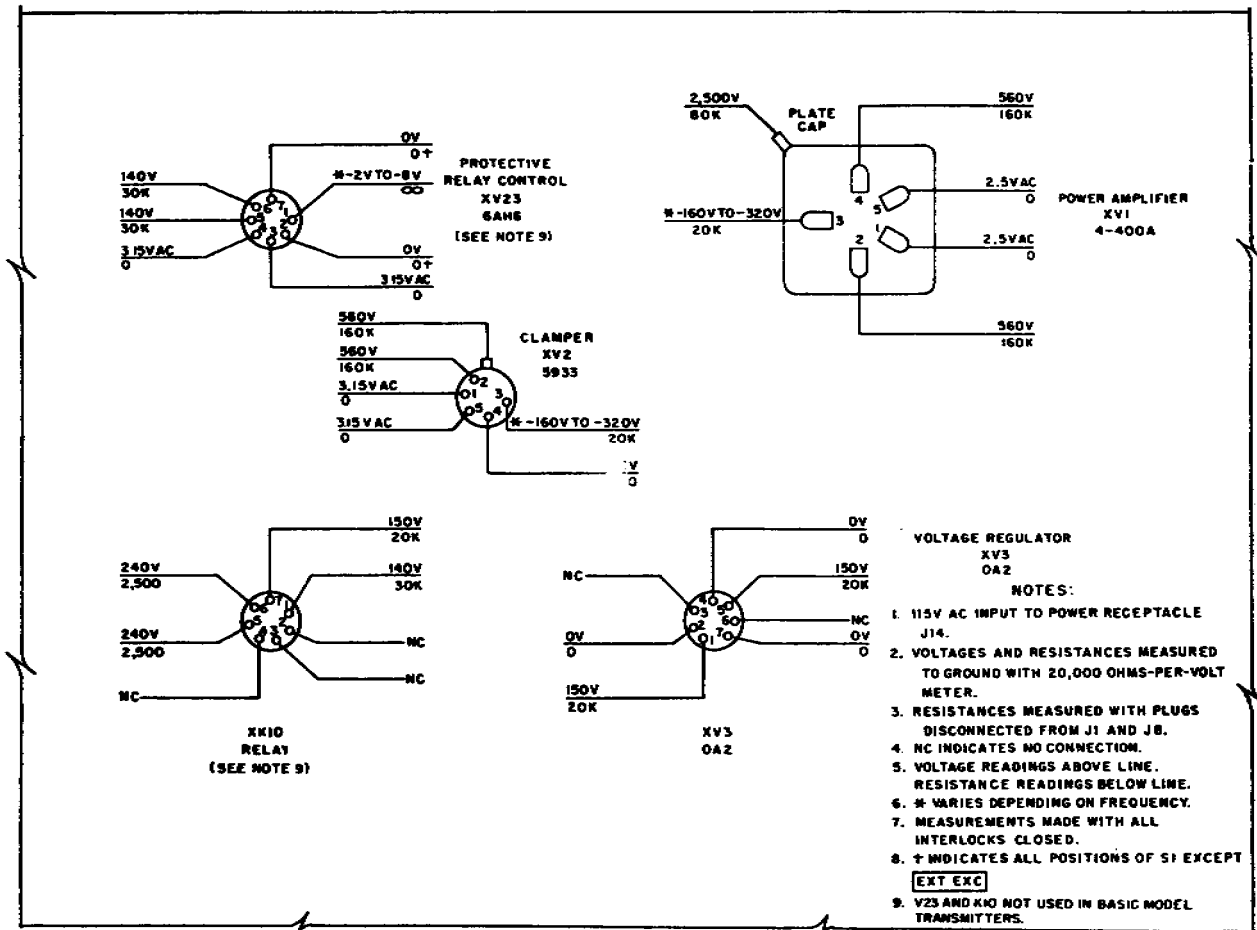

TM809-35-17

Figure 55. RF deck voltage and resistance data at V1, V2, V3, V23, and K10 sockets.

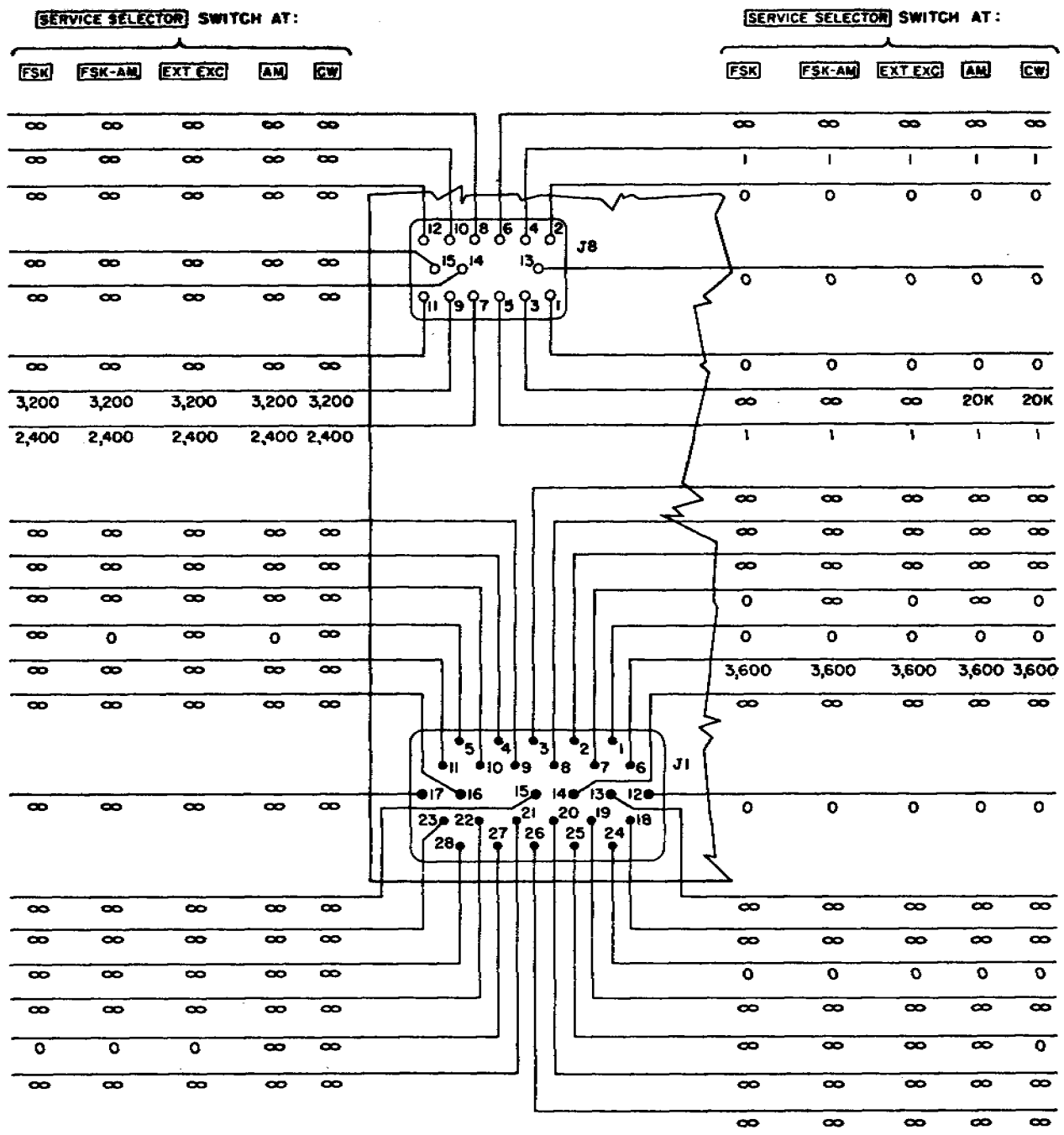

- NOTES:**
1. RESISTANCES MEASURED TO GROUND WITH 20,000 OHMS-PER-VOLT METER.
  2. MEASUREMENTS MADE AT J1 WITH PI DISCONNECTED, AND WITH OSCILLATOR AND MULTIPLIER SUBASSEMBLIES PLUGGED INTO J8. MEASUREMENTS MADE AT J8 WITH PI DISCONNECTED FROM J1.
  3. RESISTANCE READINGS BELOW LINE.

Figure 56. RF deck, J1 and J8 resistance data, basic model transmitters. TM 809-53  
AGO 2742A

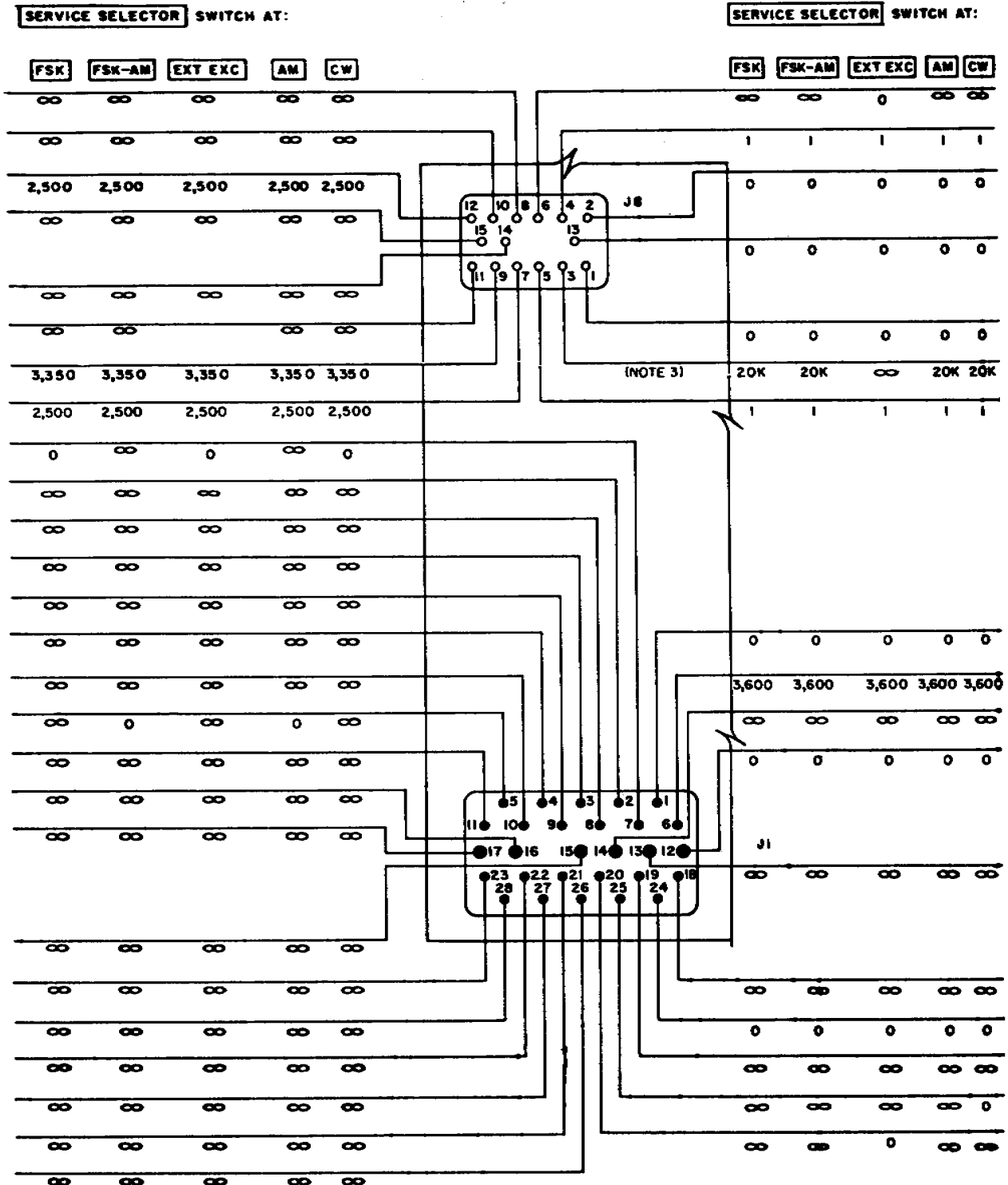

**NOTES:**  
 1. RESISTANCES MEASURED TO GROUND WITH 20,000 OHMS-PER-VOLT METER.  
 2. MEASUREMENTS MADE AT J1 WITH PI DISCONNECTED AND WITH OSCILLATOR AND MULTIPLIER SUBASSEMBLIES PLUGGED INTO J8. MEASUREMENTS MADE AT J8 WITH PI DISCONNECTED FROM J1.  
 3. IN A MODEL TRANSMITTERS, PIN 3 OF J8 IS ∞ IN [FSK] AND [FSK-AM] POSITIONS.

TM 809-35-18

Figure 57. RF deck J1 and J8 resistance data, lettered model transmitters.



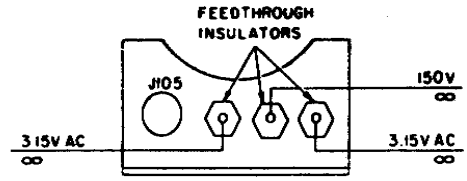

- NOTES:
1. 115V AC INPUT TO POWER SOCKET **J14**
  2. **SERVICE SELECTOR** SWITCH AT **AM** OR **CW**
  3. VOLTAGES AND RESISTANCES MEASURED TO GROUND WITH 20,000 OHMS-PER-VOLT METER
  4. RESISTANCES MEASURED WITH P101 DISCONNECTED FROM J8.
  5. VOLTAGE READINGS ABOVE LINE, RESISTANCE READINGS BELOW LINE.
- TM 809-54

Figure 58. RF deck- terminal bracket, voltage and resistance data.

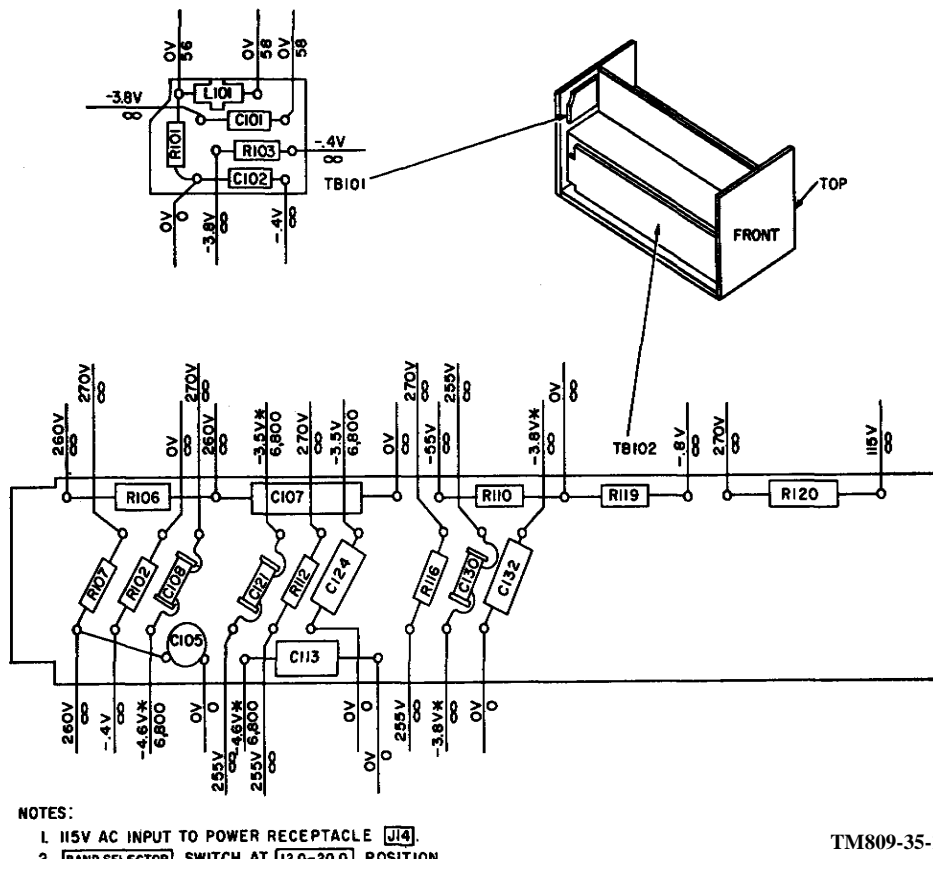

- NOTES:
1. 115V AC INPUT TO POWER RECEPTACLE **J14**.
  2. **SERVICE SELECTOR** SWITCH AT **(AM-CW)** POSITION.
- TM809-35-19

Figure 59. Multiplier subassembly terminal boards, voltage and resistance data.

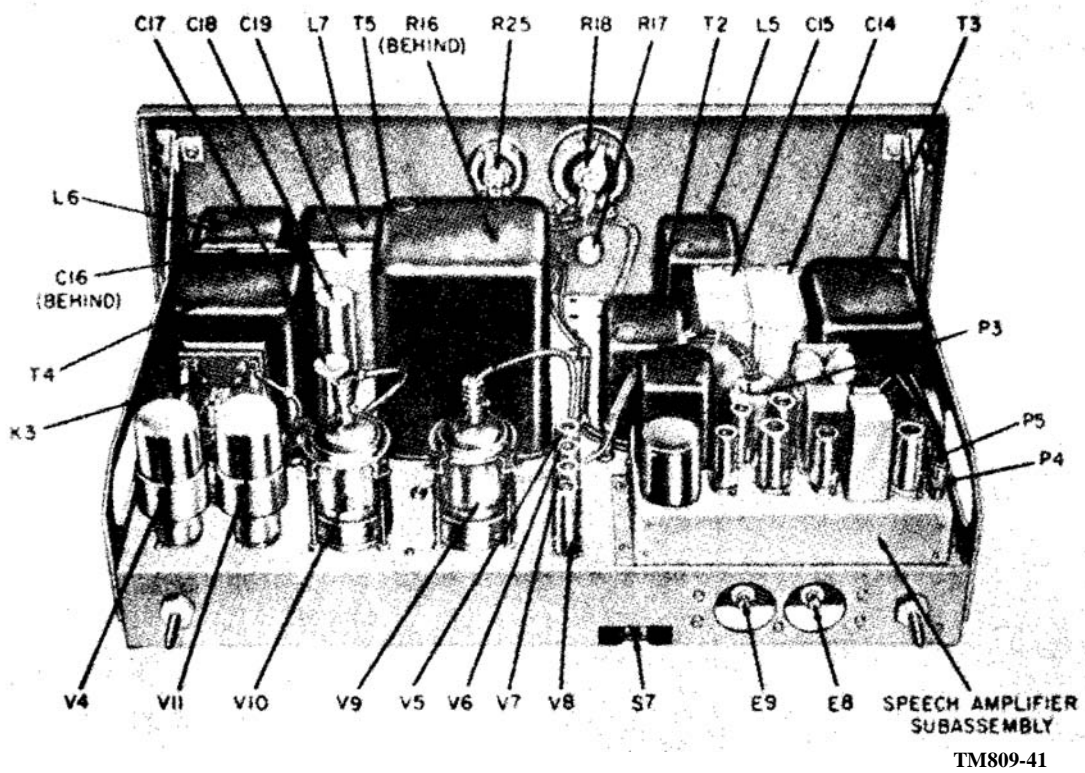
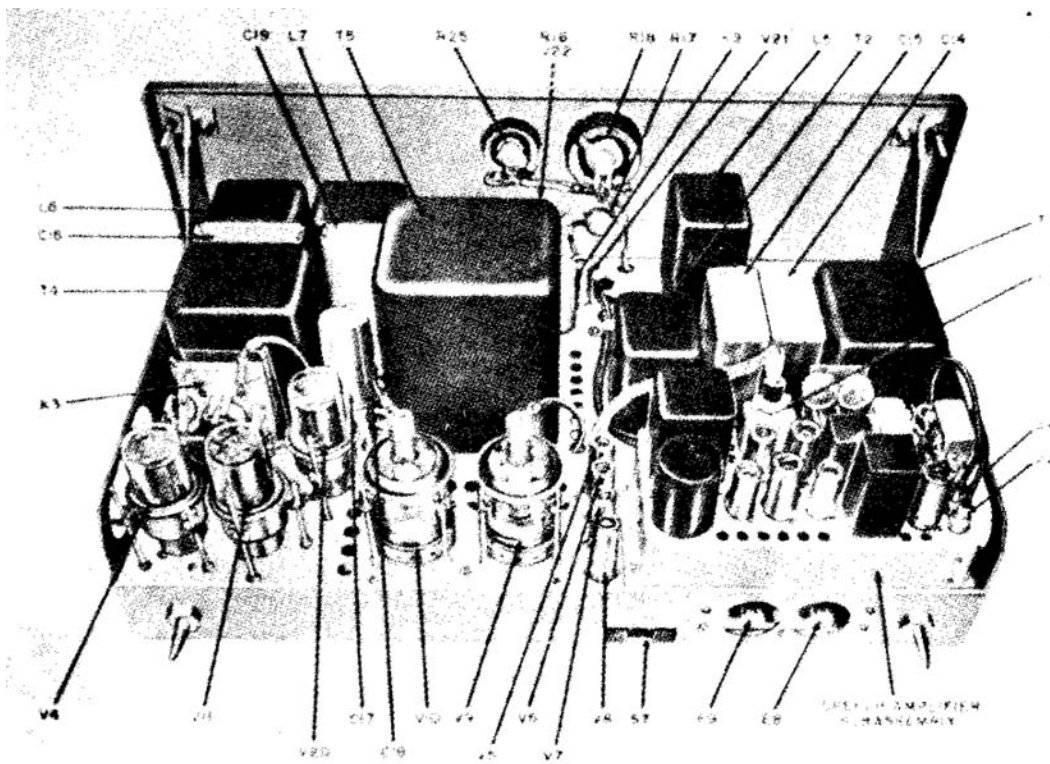
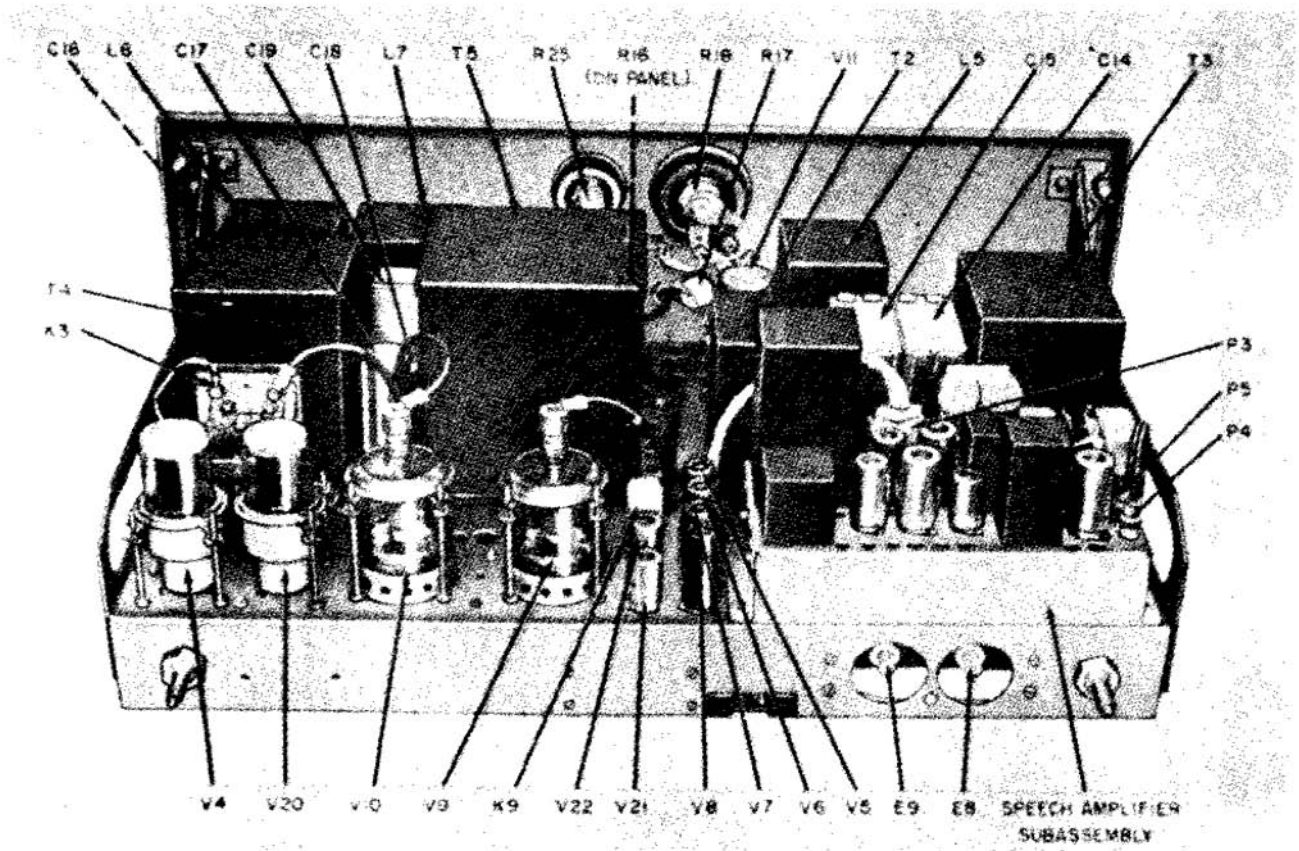

Figure 60. Modulator deck top view, basic model transmitters.



TM809-C1-4

Figure 61. Modulator deck, top view, B model and C model transmitters on Order No. 43056-Phila-56.



TM809-C2-19

Figure 62. Modulator deck, top view, C model transmitters on Order No. 28459-Phila-55.

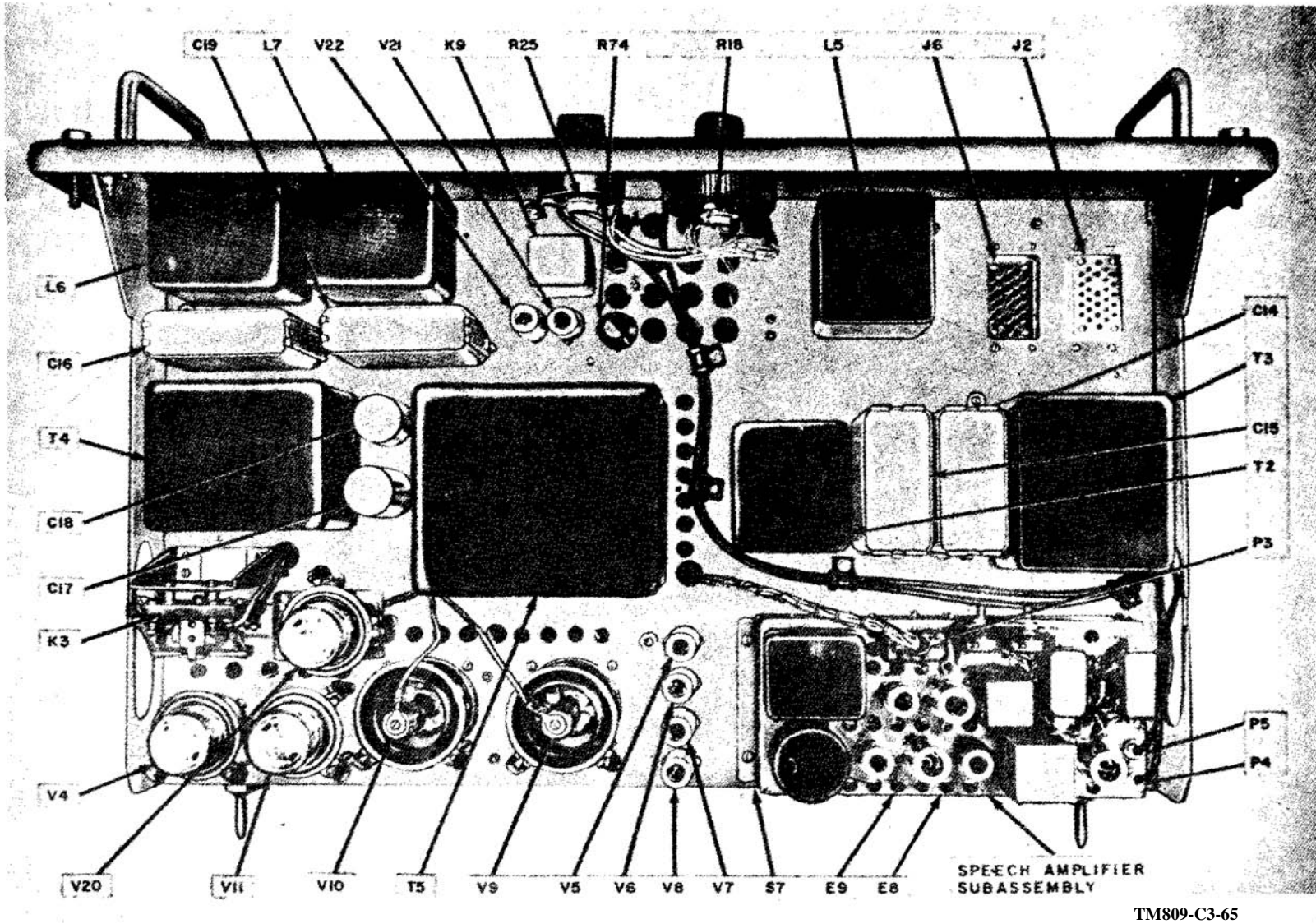

TM809-C3-65

Figure 63. Modulator deck, top view, C model transmitters on Order No. 28597-Phila-55.

AGO 2742A

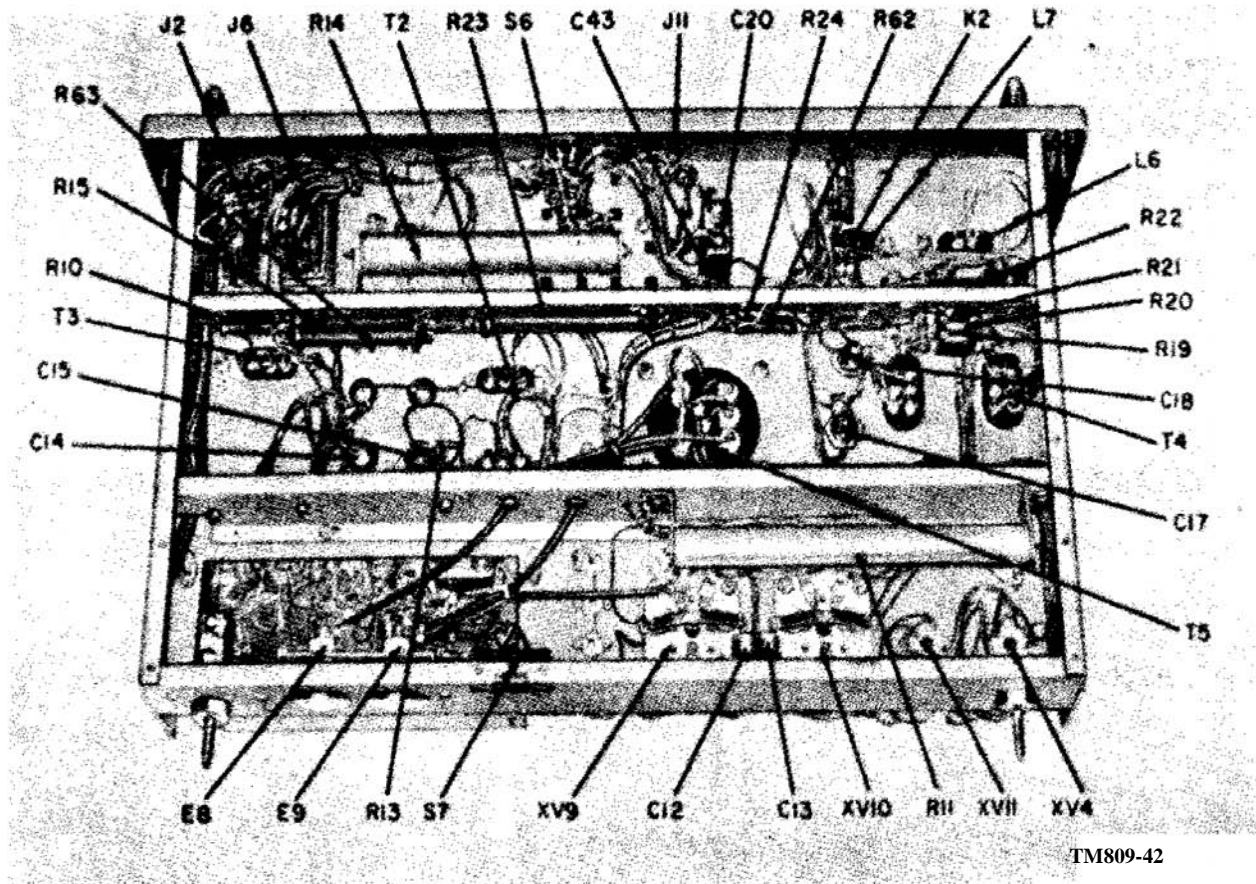
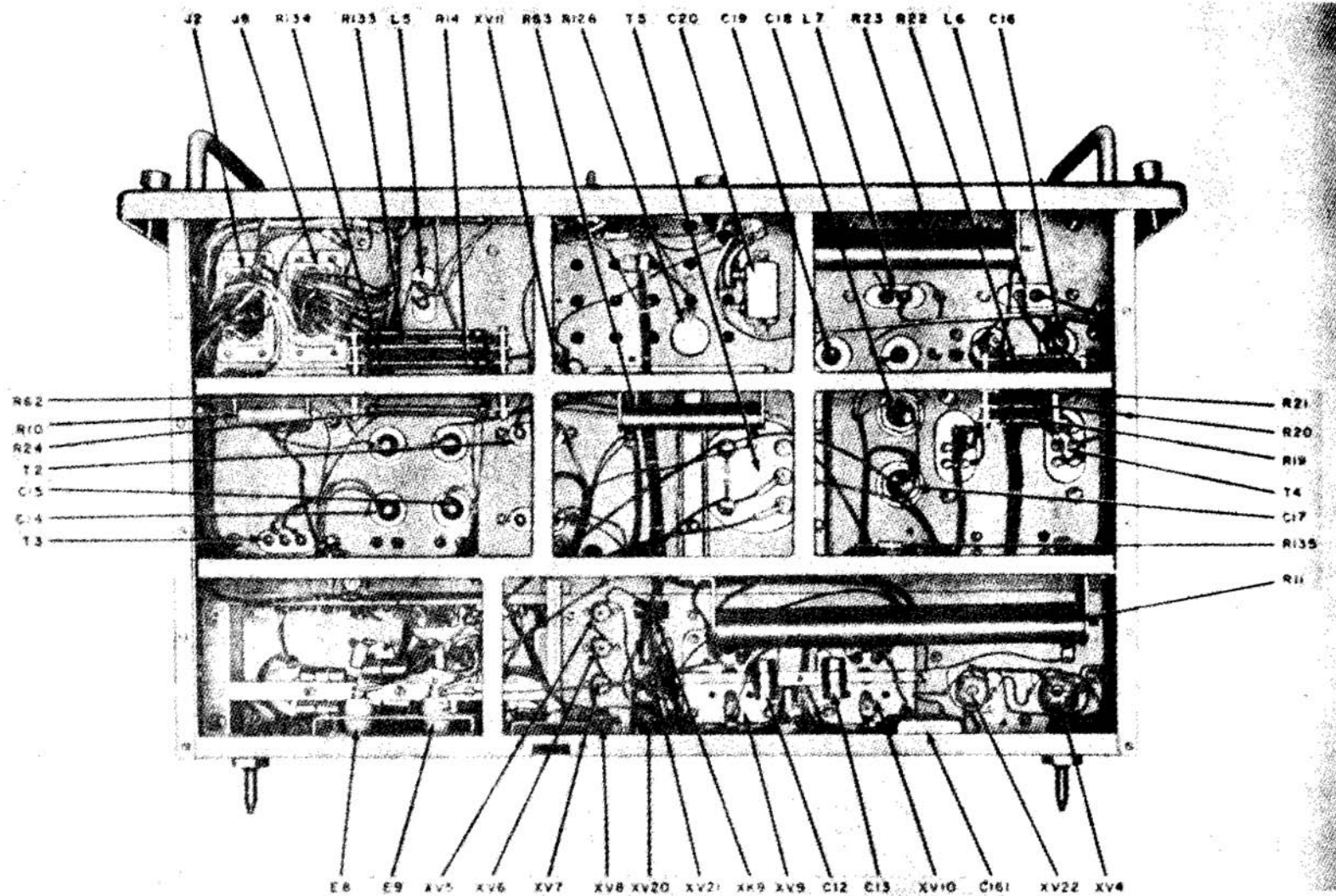

Figure 64. Modulator deck, bottom view, basic model transmitters.





TM809-C4-21

Figure 65. Modulator deck, bottom view, A model transmitters.

AGO 2742A

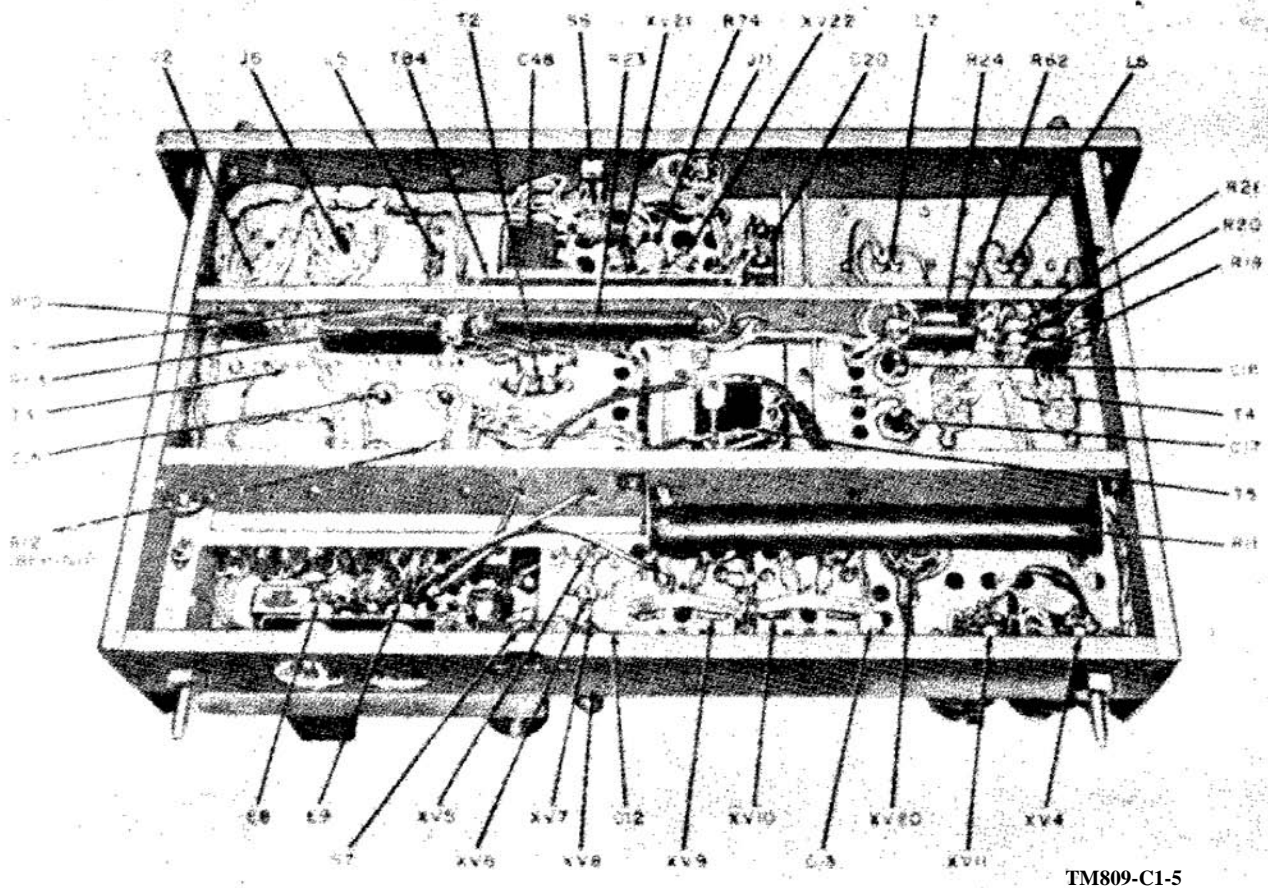
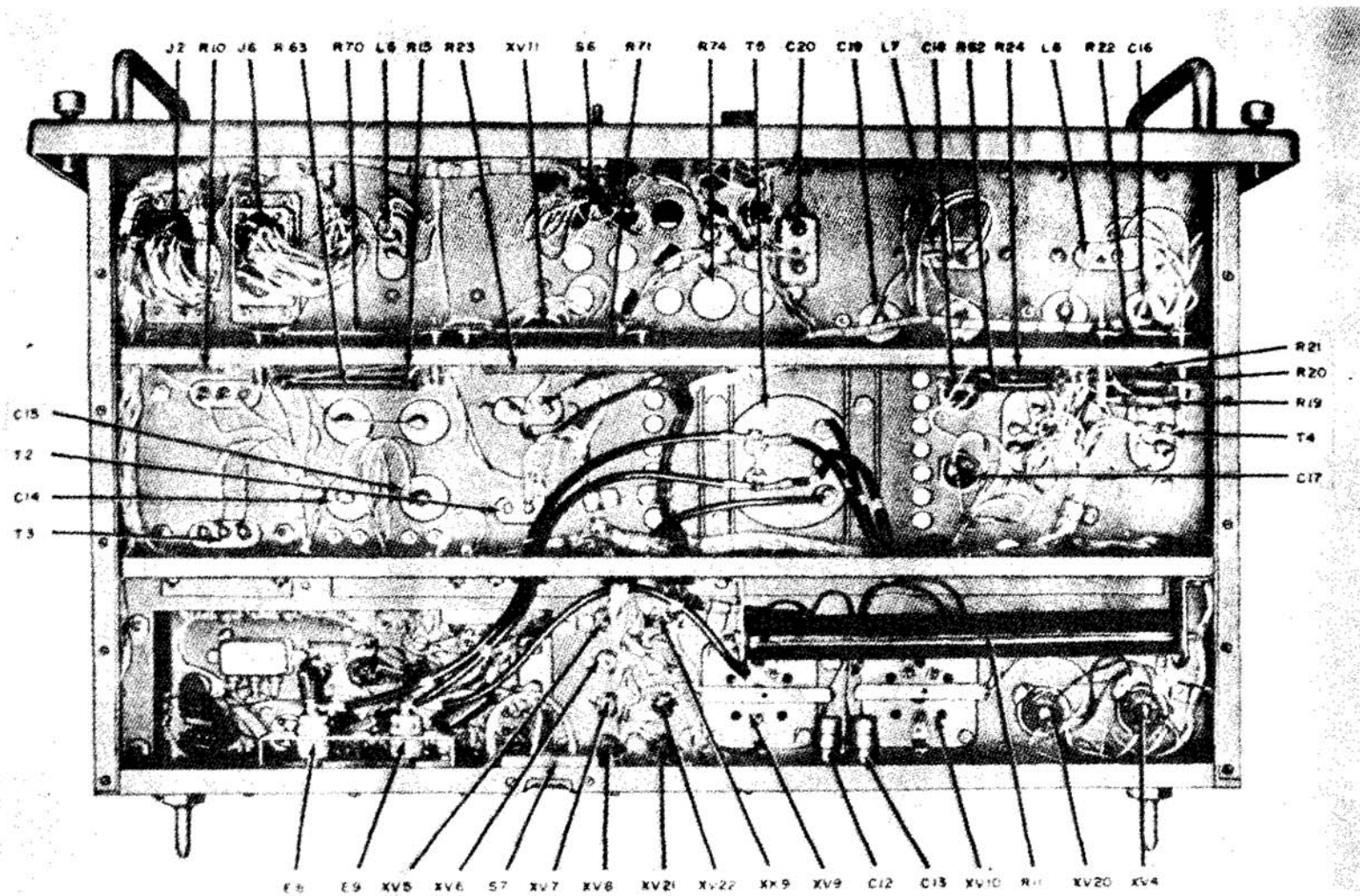

Figure 66. Modulator deck, bottom view, B model and C model transmitters on Order No. 43056-Phila-56.





TM809-C2-20

Figure 67. Modulator deck, bottom view, C model transmitters on Order No. 28459-Phila-55.

AGO 2742A

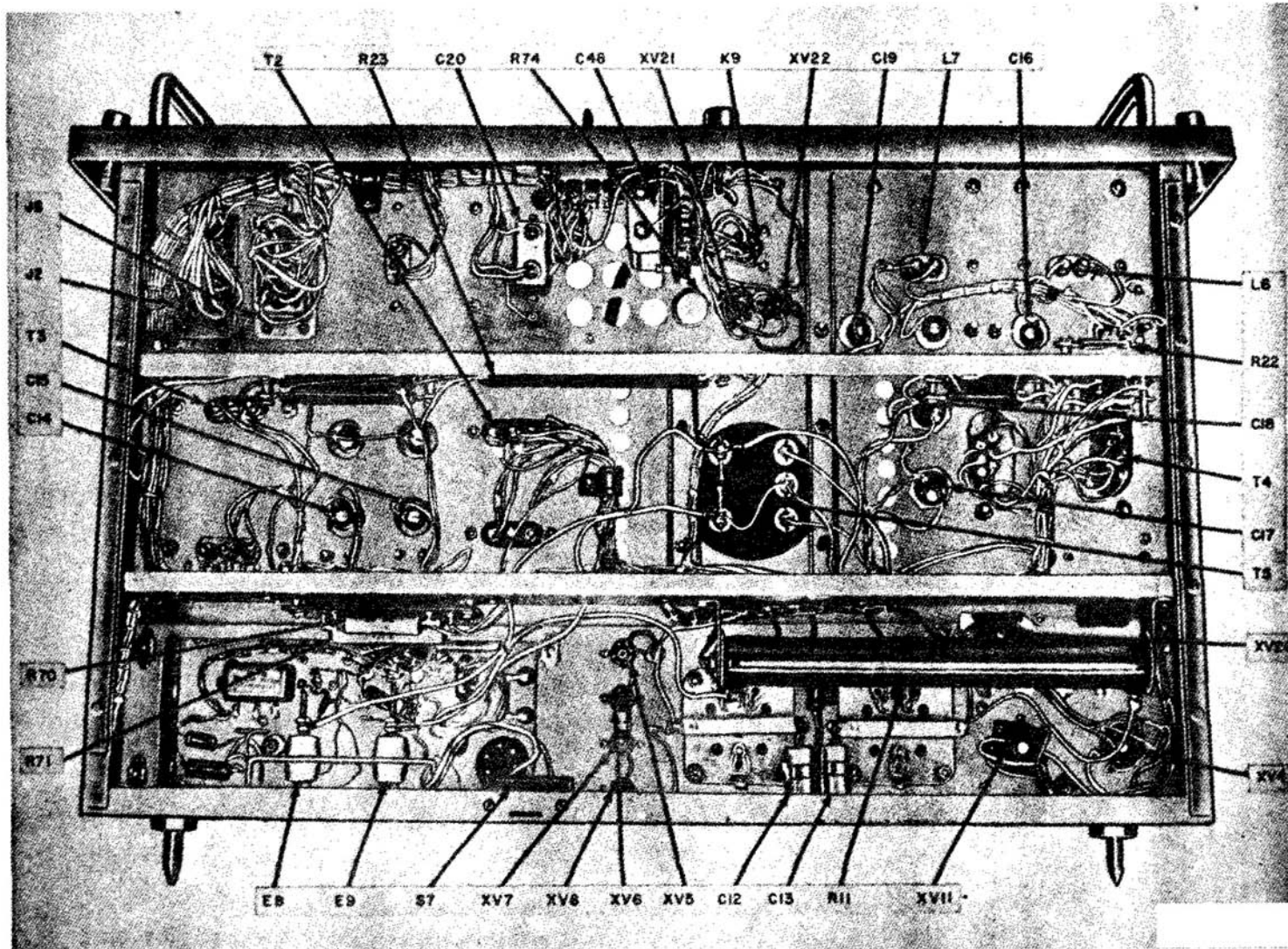

TM809-C3-66

Figure 68. Modulator deck, bottom view, C model transmitters on Order No. 28597-Phila-55.

AGO 2742A

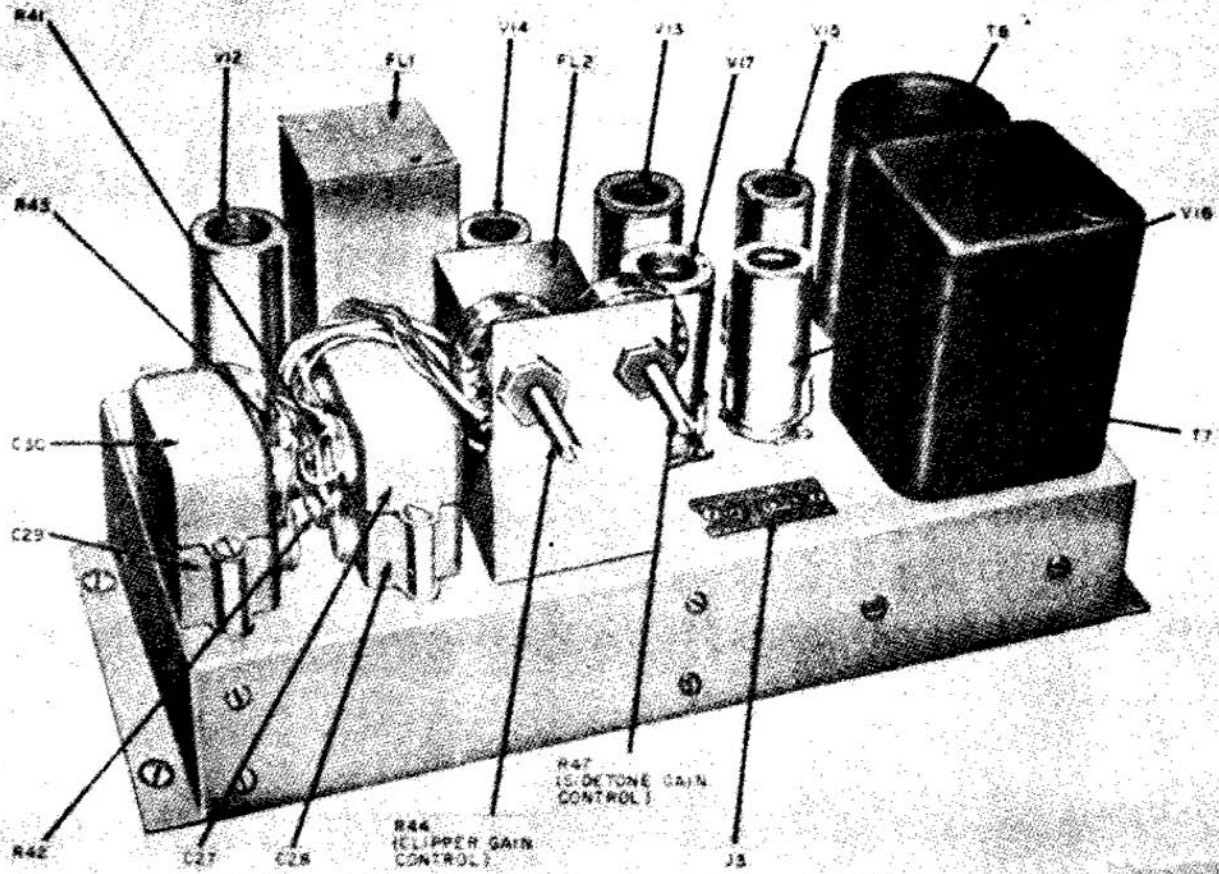

NOTE:  
 IN A MODEL TRANSMITTERS, THE POSITIONS  
 OF FL1 AND V12 ARE INTERCHANGED.

TM809-35-20

Figure 69. Speech amplifier subassembly, top view.

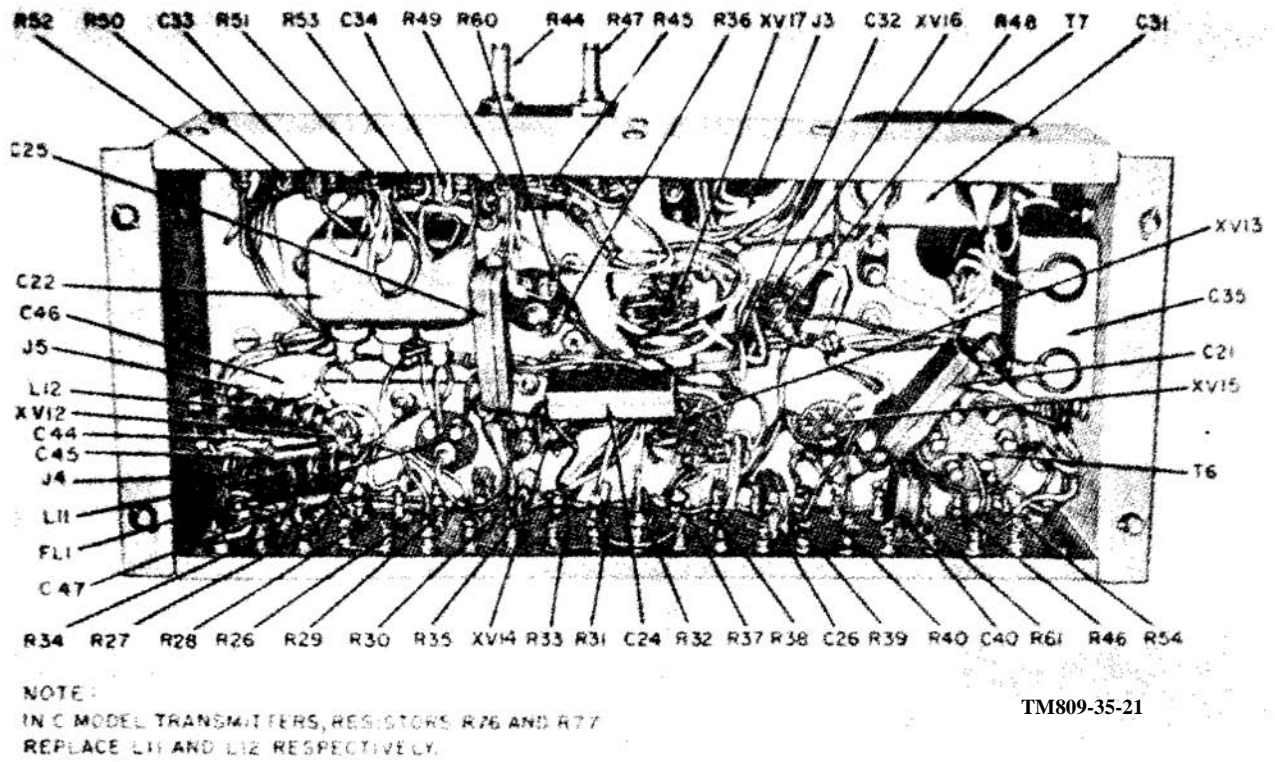

Figure 70. Speech amplifier subassembly, bottom view, basic, B, and C model transmitters.

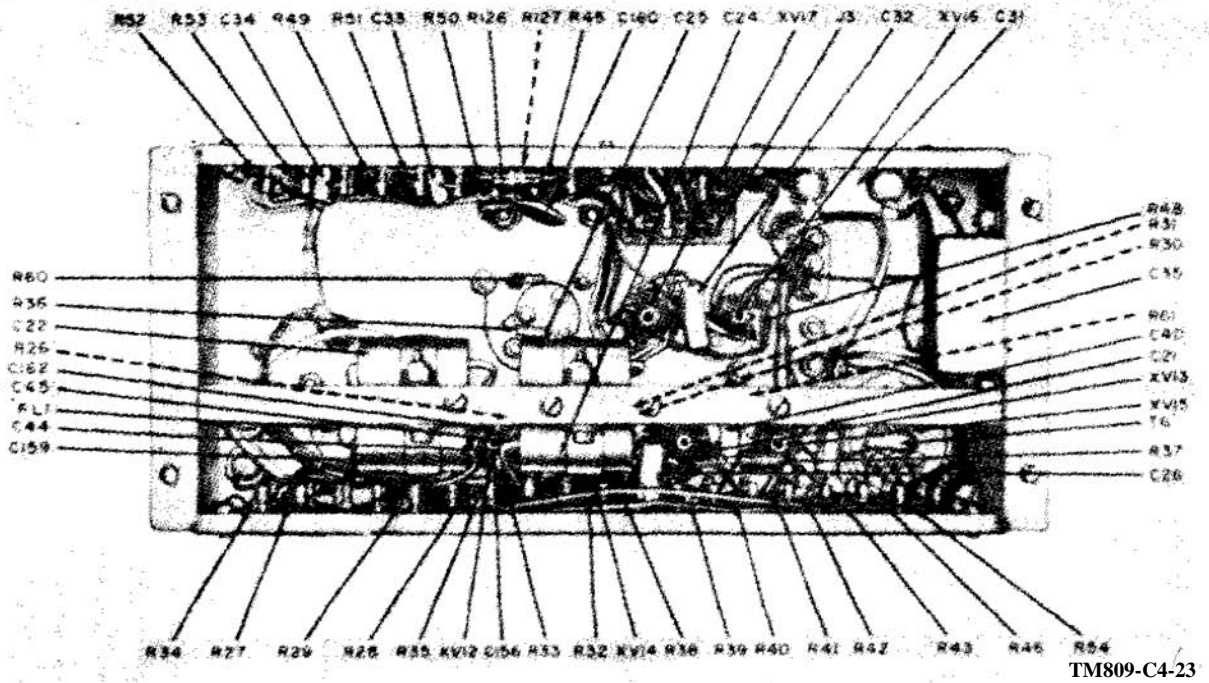
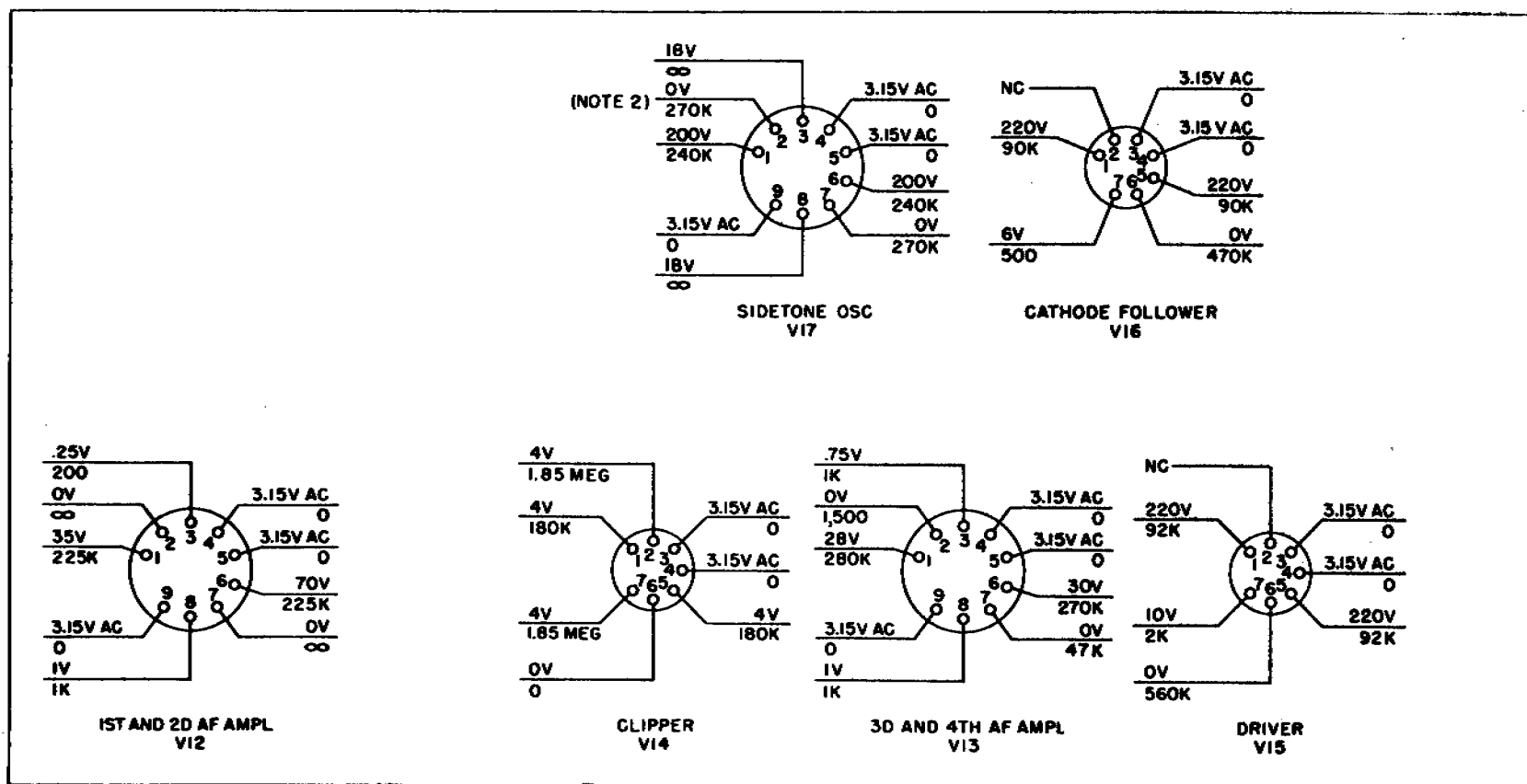

Figure 71. Speech amplifier subassembly, bottom view, A model transmitters.



**NOTES:**

1. 115V AC INPUT TO POWER RECEPTACLE **J14**
2. IN B AND C MODEL TRANSMITTERS, READINGS AT TERMINAL 2 OF V17 ARE -50V, infinity.
3. CLIPPER CONTROL (R44) TURNED TO OFF (CCW POSITION).
4. SERVICE SELECTOR SWITCH IN **FSK** POSITION
5. VOLTAGES AND RESISTANCES MEASURED TO GROUND WITH 20,000 OHMS-PER-VOLT METER.
6. NC INDICATES NO CONNECTION.
7. RESISTANCE READINGS MADE WITH P3 REMOVED FROM J3.

TM809-35-22

Figure 72. Speech amplifier subassembly tube socket voltage and resistance data, basic, B, and C model transmitters.

AGO 2742A

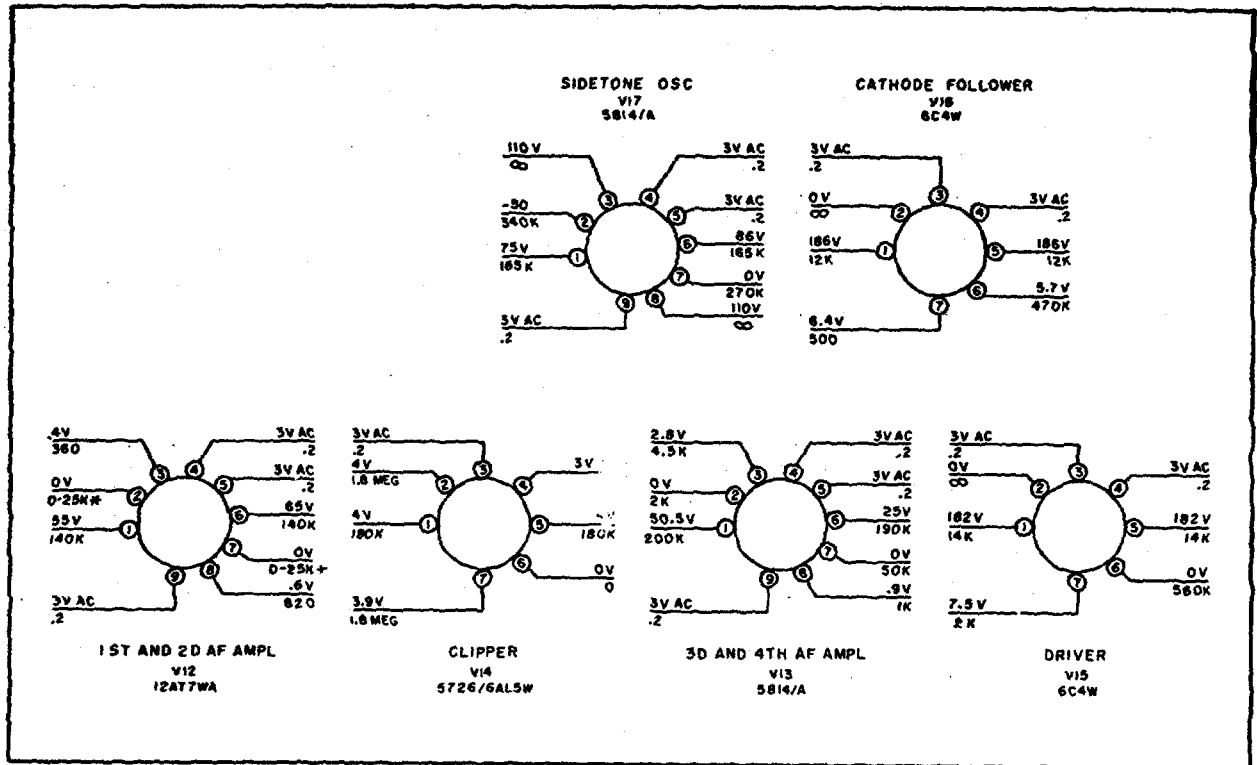

NOTES:

1. 115V AC INPUT TO POWER RECEPTACLE [14].
2. READINGS ABOVE THE LINE ARE DC VOLTS UNLESS OTHERWISE SPECIFIED.
3. READINGS BELOW THE LINE ARE IN OHMS.
4. ALL READINGS TAKEN TO GND WITH A 20,000 OHMS-PER-VOLT METER.
5. ALL READINGS TAKEN WITH TRANSMITTER NOT KEYED AND SERVICE SELECTOR SWITCH IN [FSR] POSITION.
6. \* DEPENDS ON SETTING OF R17.
7. † DEPENDS ON SETTING OF R17.

TM809-C4-30

Figure 73. Speech amplifier subassembly tube socket voltage and resistance data, A model transmitters.



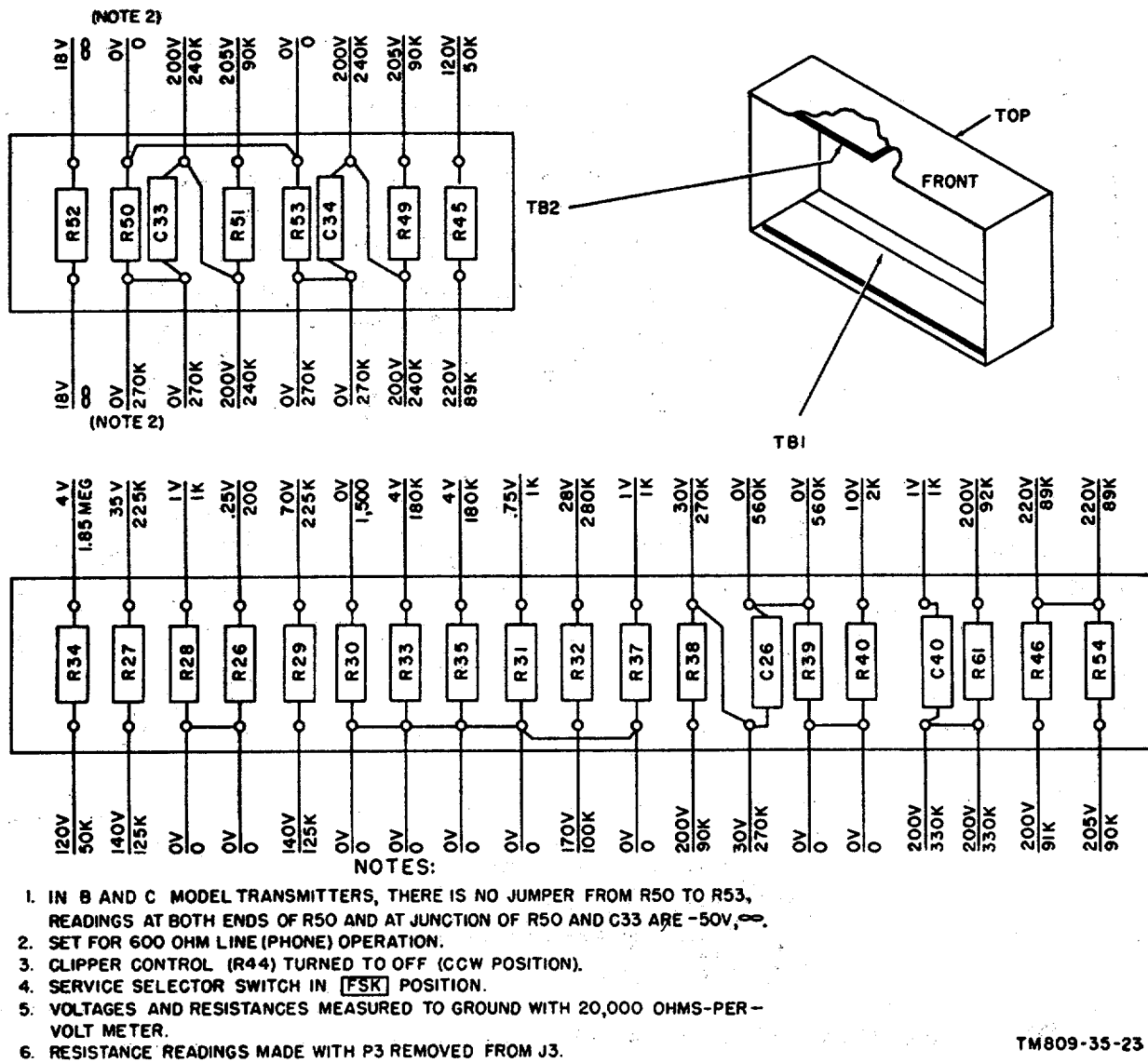
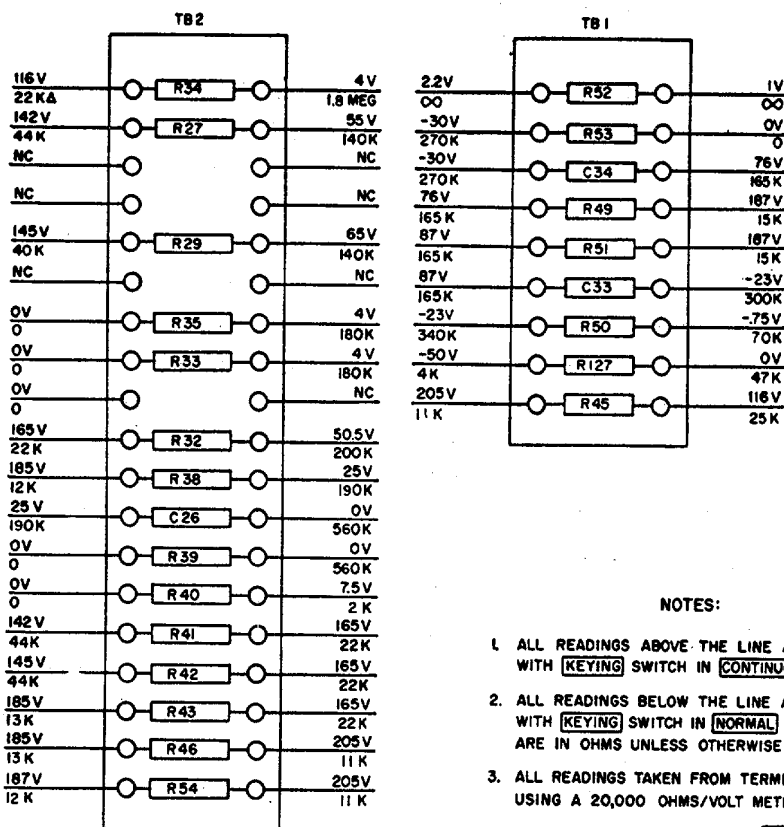

Figure 74. Speech amplifier terminal board voltage and resistance data, basic, B, and C modes transmitters.



**NOTES:**

1. ALL READINGS ABOVE THE LINE ARE DCV AND WITH **KEYING** SWITCH IN **CONTINUOUS** POSITION.
2. ALL READINGS BELOW THE LINE ARE TAKEN WITH **KEYING** SWITCH IN **NORMAL** POSITION AND ARE IN OHMS UNLESS OTHERWISE SPECIFIED.
3. ALL READINGS TAKEN FROM TERMINAL TO GND, USING A 20,000 OHMS/VOLT METER.
4. SERVICE SELECTOR SWITCH IN **FSK** POSITION.
5.  $\Delta$  DEPENDS ON SETTING OF R44.

TM809-C4-31

Figure 75. Speech amplifier terminal board voltage and resistance data, A model transmitters.

**27. Test Equipment Required for Troubleshooting**

The test equipment required for troubleshooting Radio Transmitter T-368(\*)/URT is listed below.

Nomenclature	Common name
Audio Oscillator TS-382A/U.	Audio oscillator.
Frequency Meter AN/URM-32.	Frequency meter.
Multimeter AN/URM-105	Multimeter.
Oscilloscope OS-8A/U	Test scope.
Signal Generator AN/URM-25D.	Signal generator.
Electron Tube Test Set TV-2/U.	Tube tester.

**28. General Precautions**

Observe the following precautions when servicing the transmitter:

AGO 2742A

a. Be very careful when servicing the equipment with the interlocks bypassed. Dangerous voltages are exposed.

b. Careless replacement of parts often makes new faults inevitable. Note the following points:

- (1) Before a part is unsoldered, note the position of the component and the placement of its leads. If the part, such as a power transformer, has a number of connections, tag each lead.
- (2) Do not use a large soldering iron when soldering small resistors or ceramic capacitors. A large soldering iron used in a narrow, confined area can damage nearby components. Overheating of the small parts may ruin or change the value of the component.
- (3) Make well-soldered joints. A poorly soldered joint, which can cause intermittent and poor operation, is one of the most difficult faults to find.



(4) When a part is replaced in a high-frequency circuit, it must be placed in the exact position occupied by the original part. A part that has the same electrical value but different physical dimensions may cause trouble in these circuits. Give particular attention to proper grounding when replacing a part; use the same ground as that used in original wiring. Failure to observe these precautions may result in improper operation.

(5) *Do not disturb* any of the alinement adjustments unless it definitely has been determined that trouble is caused by an adjustment that is improperly set.

c. Do not overtighten screws when assembling mechanical couplings.

d. When changing a component that is held by screws and lockwashers, always be sure to put back the lockwashers.

e. If the equipment has been operating for some time, use a cloth when removing the metal tube shields and a tube puller to remove the tubes to prevent burning the hands or fingers. For the same reason, avoid touching any of the large power resistors.

## 29. Checking Filament and B+ Circuits for Shorts

Trouble with the transmitter may often be detected by checking the resistance of the filament and B+ circuits *before applying power* to the equipment. This will also prevent damage to the power supplies in case of a short circuit. Make the following checks:

a. Remove plug P101 (fig. 39) from J8 and check resistance from pin 1 or 2 of P101 to ground. An infinite reading indicates absence of a short in the filament circuits of tubes V801, V802, and V101 through V103. (In lettered-model transmitters, the filament circuits of V801 and V802 are checked from either pin 14 or 15 of P101 or from pin 5 or 6 of T10.) Measure from pin 4 or 5 of P101 to ground. An infinite reading indicates absence of a short in the filament circuit of tube V104.

b. Remove the wire from the T7 secondary (pin 5) center tap and check from pin 4 or 6 to ground. An infinite reading indicates absence of a short in the

filament circuit of the speech amplifier tubes. In lettered-model transmitters this also checks the filament circuit of the keying diode and keying relay control tubes.

c. Remove the wire from the T1 secondary (pin 5) center tap and check from pin 4 or 6 to ground. An infinite reading indicates absence of a short in the V2 and, in lettered models, V23 filament circuits. Similarly, removing the wire from pin 11 of T1, and checking from pin 10 or 12 to ground, checks the V1 filament circuit.

d. Disconnect plug P2 from J2 (fig. 64) and check resistance from pin 4 or 6 of T2 to ground. A reading of approximately 200 ohms should be obtained. This checks the filament circuit of modulator tubes V9 and V10.

e. Check resistance from the filaments of V19 or V18 to ground. The resistance should be approximately 80,000 ohms. This also checks the high-voltage power supply filter capacitors C38 and C39. If an infinite reading is obtained, check the T8 secondary, R58, or the coil of K4 for an open circuit.

f. Check the resistance from the filament of V11 to ground. The reading should be approximately 100 ohms. This checks the filament circuit of V11 and filter capacitors C17 and C18 in the carbon microphone power source line.

g. Check the resistance from a plate pin (pin 4 or 6) of V11 to ground. The reading should be approximately 3,500 ohms. This checks the filter capacitors (C16 and C19) of the bias power supply.

h. Check the resistance from the filament of the exciter rectifier tube (2 tubes in parallel in lettered-model transmitters). The resistance should be approximately 3,000 ohms. This checks the exciter rectifier filament circuit and power supply filters C14 and C15.

## 30. Operational Test

With the transmitter connected for normal operation, operate it as described in the equipment performance checklist in TM 11-809-20. The checklist is important since it frequently indicates the general location of trouble. Listen for crackling or buzzing noises that indicate

high-voltage arcing. Also check for smoke and the odor of burned or overheated parts. If smoke or odor is present, turn the set off immediately to prevent further damage to the equipment.

### 31. Troubleshooting Chart

The chart below is supplied as an aid in locating trouble in the transmitter. It lists the symptoms that the

repair-man observes, either visually or aurally, while making a few simple tests. The chart also indicates how to localize trouble quickly to a deck, subassembly, or circuit. After the trouble has been localized to a stage of a circuit, a tube check and voltage and resistance measurements of this stage or circuit ordinarily should be sufficient to isolate the defective parts.

Symptom	Probable trouble	Correction
FILAMCNT POWER circuit breaker ON. No green light, blower motors not running, and no reading on FIL VOLTAGE meter.	No ac to equipment .....	Check power Cord CD-763, receptacle J14, FILAMCNT POWER circuit breaker CB1, and THERMAL RESET; switch S13. Repair or replace as needed.
BLOWN FUSE INDICATOR lamp below 6 amp fuse lighted.	Fuse F1 blown.....	Replace fuse F1.
BLOWN FUSE INDICATOR below 3 AMP fuse lighted and green light on.	Fuse F2 blown .....	Replace fuse F2.
Green light and blower B2 on back panel on. Blower B1 on Fr deck not operating and no reading on FIL VOLTAGE meter. No tube filaments lighted.	FILAMCNT VOLTAGE control R18 open	Check and repair or replace R18 required.
Green light on, no reading on FIL VOLTAGE meter. Speech amplifier and modulator tubes lighted.	Executor and pa filament transformer T1 defective.	If pa tube is lighted, check meter M1 replace. If pa tube is not lighted, check and replace transformer T1.
Blowers are on, FIL VOLTAGE meter indicates, all filaments on except master oscillator and 1st buffer.	Meter M1 defective .....	Check transformer T10 for open circuit (T10 is only used in lettered models.) Connect plug to jack.
No reading on EXCITATION meter in P A GRID X2 position with EXCITER PLATE POWER switch in <i>on</i> (up) position. (KEYING switch in CONTINUOUS in lettered model transmitters.)	Filament transformer T10 (lettered models only). P802 not connected to J105 .....	Check V104 and circuit components and replace defective parts.
	Ipa stage defective .....	Check S14. Repair or replace as necessary
	Lettered-model transmitters: Interlock switch S14 defective or open.	Check and replace.
	Protective relay K10 defective.	Check and replace.
	Relay control tube V23 defective.	Check seating of plugs and connector adapters. (See par. 10 and fig. 5 of TM 11-809-20.)
	Internal cabling loose or defective.	Check T3 and connections; executor rectifier tubes; L5, C14, C15. Replace if necessary.
	No executor B+ voltage .....	Check and replace.
	EXCITATION meter M2 defective	Replace I 4.
FILAMCNT POWER circuit breaker ON. PLATE POWER indicator light not lighted (about 25 seconds after filament power is applied) with PLATE RELAY switch on and TUNE-OPERATE (TUNE-PANEL IN A model transmitters and C model transmitters on Order No. 28459-Phila-55) switch in TUNE position.	PLATE POWER indicator light I 4 burned out. PLATE POWER circuit breaker CB2 defective.	Check CB2 and repair or replace, as needed
	Interlock circuit open; deck may not be fully in housing.	Be sure that all decks are fully in housing. Check interlock switches and repair if necessary.
	Plate relay K6 defective .....	Replace K6.
	Contacts of K8 defective .....	Replace K8.
	Tic delay relay K7 defective	Replace K7.

AGO 2742A

Symptoms	Probable trouble	Correction
<p>In key-down position, PLATE POWER indicator light on and reading obtained on INT AMP PLATE X10 setting of EXCITATION METER SWITCH, but no P A GRID X2 reading obtained, P A PLATE reading very low, and no output present.</p> <p>In basic and A model transmitters, P A GRID X2 reading obtained when in FSK operation, but no reading when in CW or AM operation.</p> <p>No P A GRID X2 reading obtained when in 1.5-3.0 mc for FSK or CW operation. Equipment operates with external excitation input.</p> <p>No P A GRID X2 reading obtained when on 3.0-6.0 mc band, for FSK or CW operation. Operates on 1.5-3.0 band; operates with external excitation input.</p> <p>No P A GRID X2 reading obtained when on 6.0-12.0 mc band, for FSK or CW operation. Operates on 3.0-6.0 mc band; operates with external excitation input.</p> <p>No P A GRID X2 reading obtained when on 12.0-20.0 mc band; for ASK or CW operation. Operates on 6.0-12.0 mc band; operates with external excitation input.</p> <p>In key-down position, PLATE POWER indicator light I 4 on, and readings obtained on P A GRID X2 and INT AMP PLATE X10 settings of EXCITATION METER SWITCH, but no reading on P A PLATE meter.</p> <p>Low RF output. P A GRID X2 reading is below normal.</p> <p>With equipment in EXT EXC operation, no output except on other modes of operation and no ANT AMP PLATE X10 reading.</p> <p>PLATE POWER circuit breaker opens during operation.</p>	<p>Overload reset relay K5 kept in operation by overload in high-voltage circuit.</p> <p>PLATE RELAY switch S10 defective.</p> <p>Microswitch S4 defective .....</p> <p>High-voltage filament transformer T8 defective.</p> <p>Ac dropping resistor R55 open ..</p> <p>High-voltage rectifier tubes V18 and V19 defective.</p> <p>Shorting plug P11 defective .....</p> <p>Shorted capacitor C2 .....</p> <p>Open resistor R1 or R2 .....</p> <p>Defective pa tube V1 .....</p> <p>Oscillator subassembly, V801 and V802 stages defective.</p> <p>Second buffer and first multiplier stage V101 defective.</p> <p>Tank circuit Z101 or Z102 defective.</p> <p>Second multiplier stage V102 defective.</p> <p>Third multiplier stage V103 defective.</p> <p>Power amplifier plate circuit components defective.</p> <p>Misalignment .....</p> <p>Burned-out cathode resistor R121 of V104 stage.</p> <p>External excitation relay K101 defective.</p> <p>Overload relay K4 defective .....</p> <p>Overload relay adjustment R56 or R57 set too low.</p> <p>Overload reset relay K5 defective.</p>	<p>Press OVERLOAD RESET switch. If overload persists, check high-voltage circuit.</p> <p>Replace S10.</p> <p>Check S4 and repair.</p> <p>Check T8 and replace.</p> <p>Check R55 and replace.</p> <p>Check V18 and V19 and replace.</p> <p>Check P11 and repair.</p> <p>Check C2 and replace.</p> <p>Check resistors and replace.</p> <p>Replace V1.</p> <p>Check stages and replace defective parts.</p> <p>Check stage and replace defective parts.</p> <p>Check Z101 and Z102, and replace defective part.</p> <p>Check stage and replace defective parts.</p> <p>Check stage and replace defective parts.</p> <p>Check for open-circuit components and replace.</p> <p>Realine ( par. 43 ).</p> <p>Check R121 and replace.</p> <p>Check K101 and replace.</p> <p>Check K4 and repair.</p> <p>Adjust to proper value.</p> <p>Check K5 and repair.</p>

Symptom	Probable trouble	Correction
Overload relay operates during CW operation, which is otherwise normal.	Overload reset relay switch S9 defective. Continuous overload.	Check S9 and replace. Check components in overload circuits and replace defective parts.
	High-voltage supply component defective.	Check L8, C38, C39, and replace.
	Modulator deck component defective.	Check T5 and replace.
In key-up position overload relay operates, turning off PLATE POWER indicator light. Overload relay operative even after OVERLOAD RESET switch is pressed.	RF deck component defective ...	Check C7, C10, and L3 and replace.
	Clamper V2 defective .....	Check V2 and replace.
	Shorted capacitor C5, C6, or C9.	Check capacitors and replace.
	Blower motor on RF deck inoperative. (Overload relay does not operate immediately.)	Check B1 and replace.
	Lettered model transmitters:	
	Protective relay K10 defective or resistor R75 open.	Check and replace.
	Protective relay control tube V23 defective.	Check and replace.
No sidetone signals during CW operation, which is otherwise normal.	Sidetone oscillator V17 or cathode follower V16 stage defective.	Check stages and replace defective parts.
Operates with carbon microphone input, but not with 600-ohm line input (or vice versa).	First at amplifier stage V12A (or second at amplifier stage V12B) defective.	Check stage and replace defective parts.
RF output in all modes of operation, but no modulation in AM.	Modulator stages V9 and V10, or speech amplifier defective.	Check stages and speech amplifier, and replace defective parts.
Excessive MOD PLATE X20 reading, uncontrollable by MODULATOR BIAS control.	Bias rectifier V11 defective .....	Check stage and replace defective parts.
	Component parts in grid circuit of modulator defective.	
No MOD PLATE X20 reading .....	Modulator filament transformer T2 defective.	Check T2 and replace.
Transmission during EXT EXC, FSK or FSK-AM operation, but no transmission during AM or CW operation.	Push-to-talk and key relay K2 (basic model transmitters).	Check K2 and repair or replace as needed.
In AM operation, pressing push-to-talk button (on microphone) does not initiate transmission; PLATE POWER indicator light does not go on. In CW operation, PLATE POWER light remains on; no sidetone oscillations. Relay K11 in B and C model transmitters (or K1 in A model transmitters) does not operate.	Defective V20, V2, or K9 (in A model transmitter; defective V21, V22, or K9 in B and C model transmitters).	Check tubes and relay K9 and replace defective item.
No output during any mode of operation, and PLATE POWER indicator light is lighted. Overload relay not energized, but abnormally high plate current flow shown on P A PLATE meter. Receiver connected to J10 operative only if not connected to the receiver disabling circuit.	Antenna changeover relay defective.	Check relay and repair or replace.
	<i>Note.</i> Relay K1B in basic model; K1 in A model; K11 in B and C model transmitters.	
During CW or AM operation, PLATE POWER indicator light goes out from overload. OVERLOAD RESET switch may temporarily reinstitute operation. Receiver connected to J10 not disabled during transmission.	Slow release relay K1A defective (basic model transmitters) K1 or K11 contacts defective (K1 in A model transmitters; K11 in B and C model transmitters).	Check relay and repair or replace.

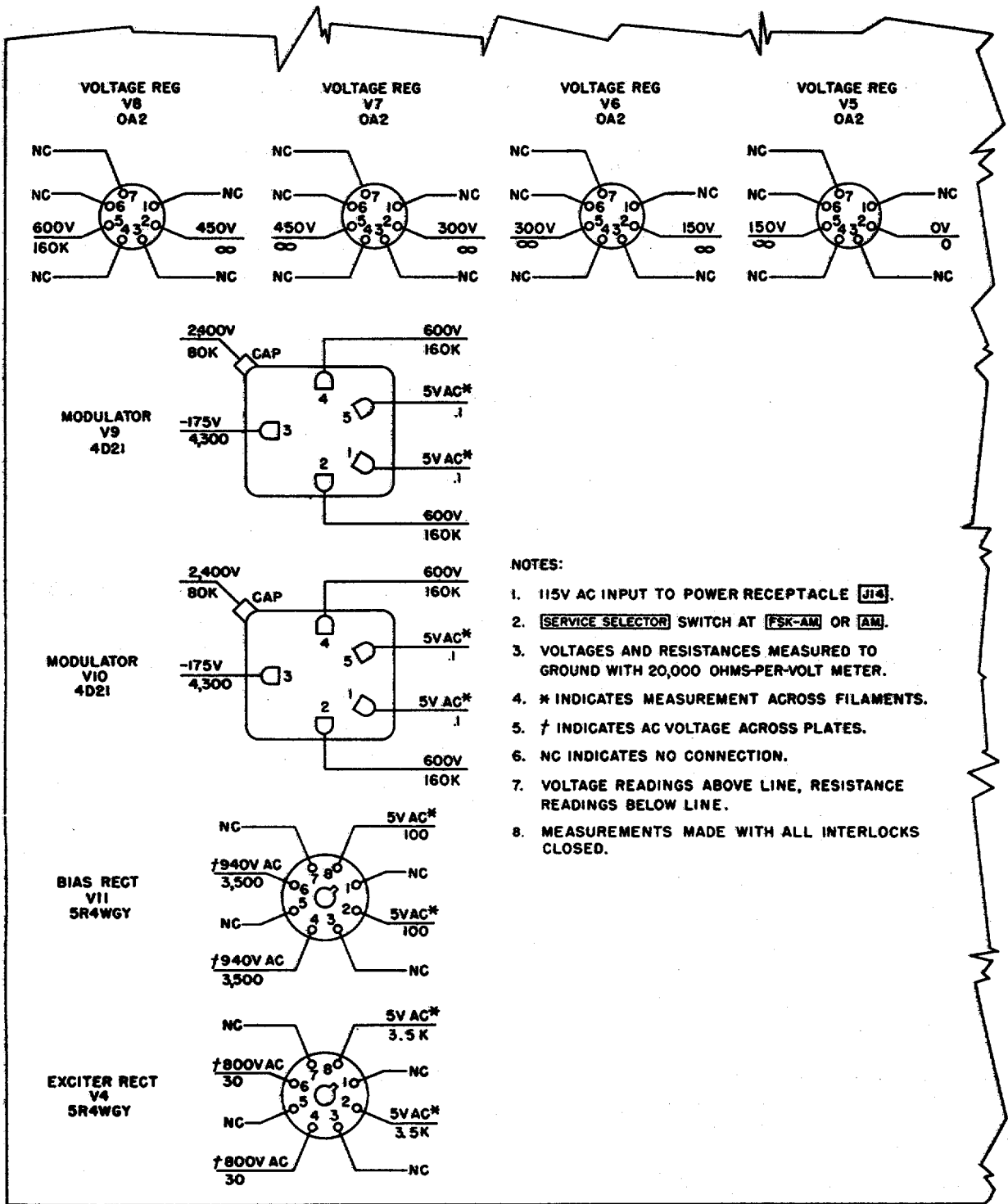

TM809-35-24

Figure 76. Modulator deck, V4 through V11, voltage and resistance data, basic model transmitters.

AGO 2742A

Symptom	Probable trouble	Correction
No output when transmitter is keyed from remote control position and PLATE RELAY switch is in OFF position.	Defective remote control receptacle J12 or cable to remote position. Defect in remote control .....	Check and repair or replace receptacle and cable. See applicable technical manual.

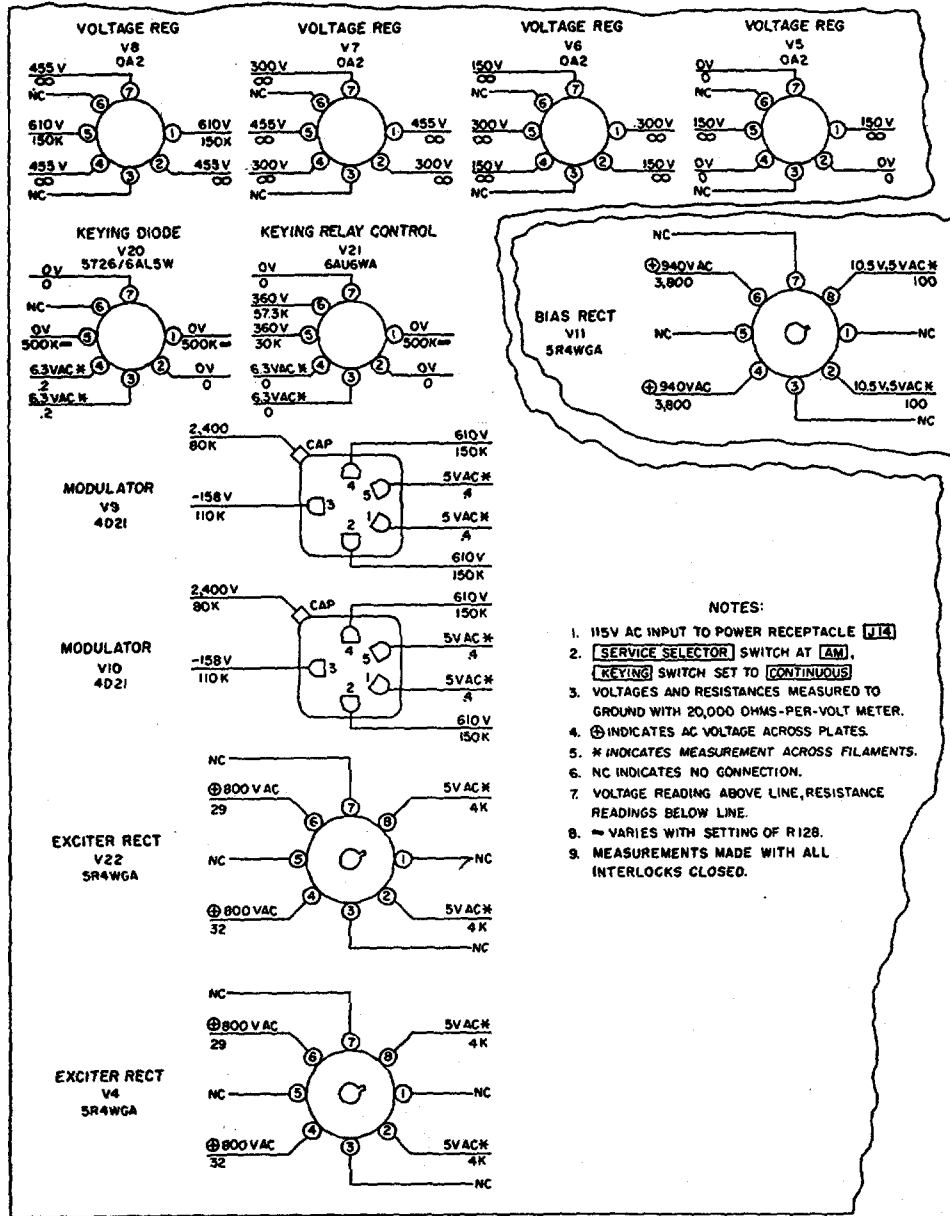

TM809-35-25

Figure 77. Modulator deck tube socket voltage and resistance data, A model transmitters.

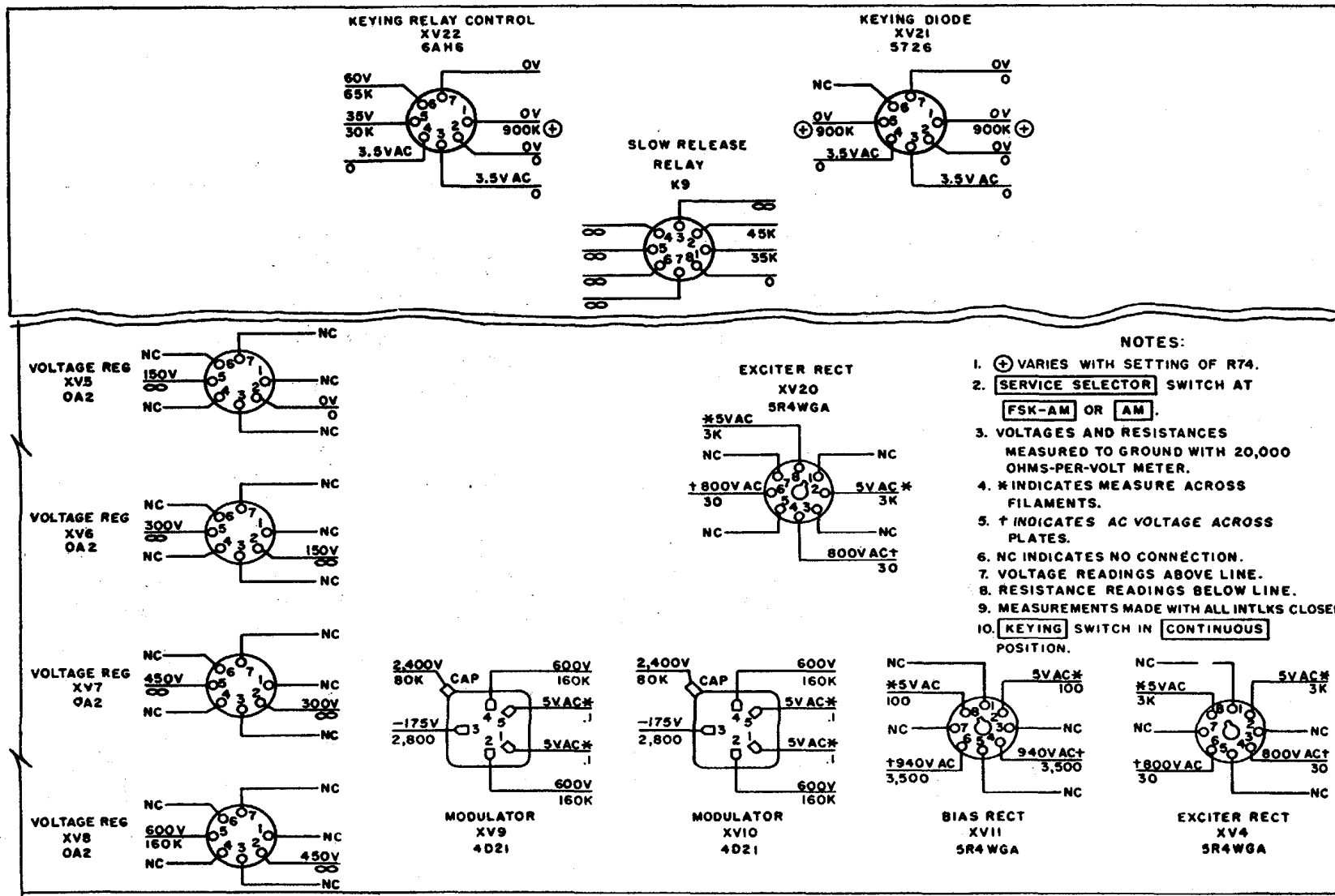
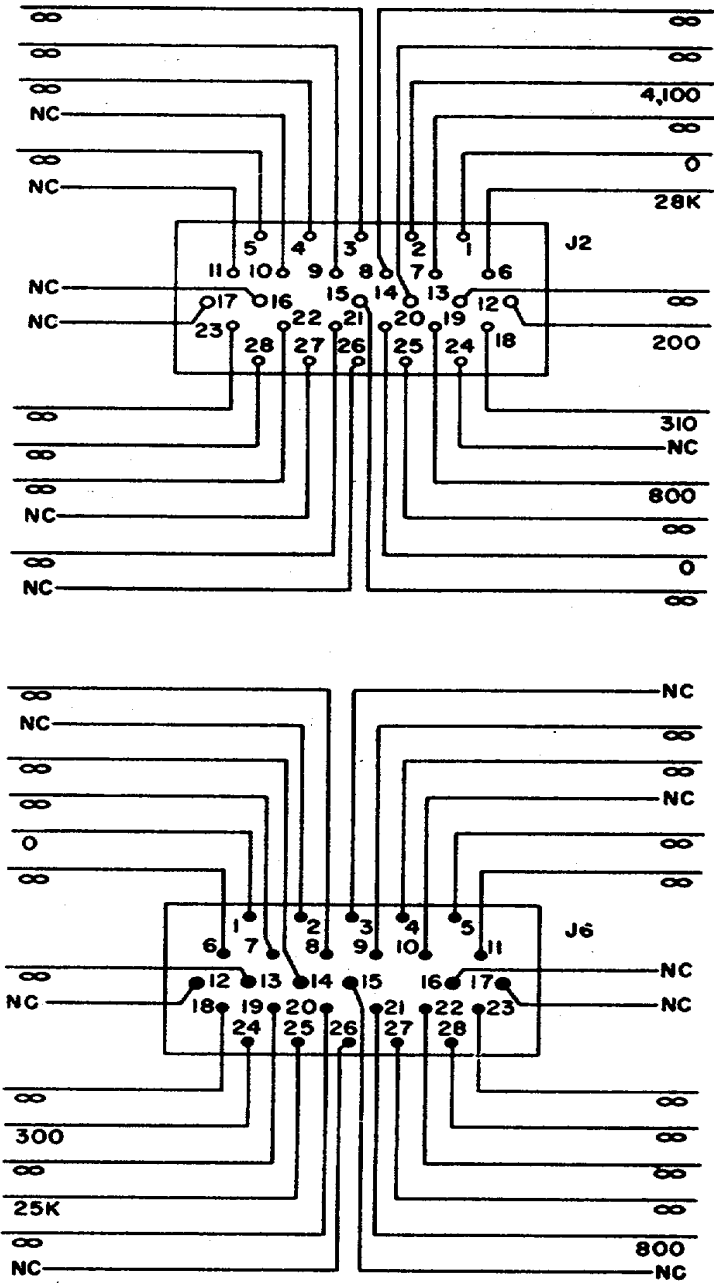

Figure 78. Modulator deck tube socket voltage and resistance data, B and C model transmitters.

AGO 2742A



- NOTES:**
1. RESISTANCES MEASURED TO GROUND WITH 20,000 OHMS-PER-VOLT METER.
  2. **EXCITER PLATE POWER** SWITCH AT ON.
  3. MEASUREMENTS MADE AT J2 WITH P6 DISCONNECTED FROM J6, AND AT J6 WITH P2 DISCONNECTED FROM J2.
  4. NC INDICATES NO CONNECTION.
  5. RESISTANCE READINGS BELOW LINE.

TM809-35-27

Figure 79. Modulator deck, J2 and J6 resistance data, basic model transmitters.

AGO 2742A



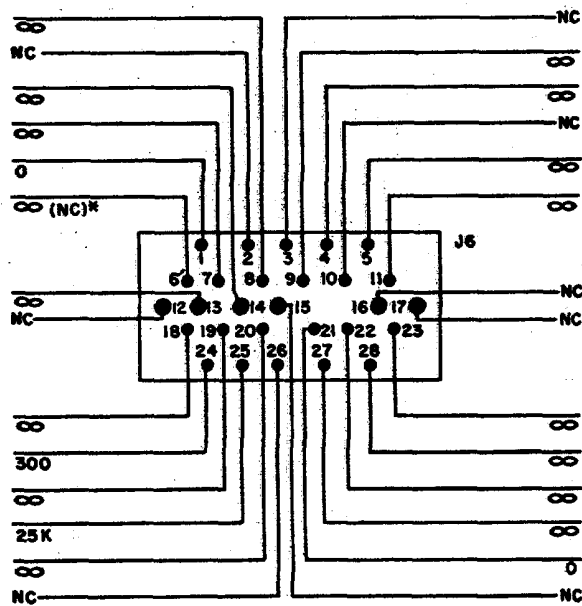
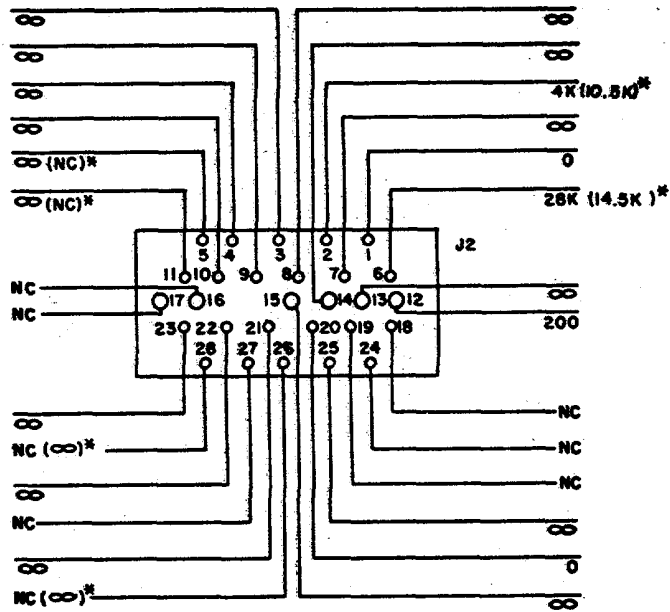

**NOTES:**

1. RESISTANCES MEASURED TO GROUND WITH 20,000 OHMS-PER-VOLT METER.
2. **KEYING** SWITCH AT **CONTINUOUS**
3. MEASUREMENTS MADE AT J2 WITH P6 DISCONNECTED FROM J6 AND AT J6 WITH P2 DISCONNECTED FROM J2.
4. NC INDICATES NO CONNECTION.
5. \*( ) IS READING FOR A MODEL TRANSMITTERS.

TM809-35-28

Figure 80. Modulator deck, J2 and J6 resistance data, lettered-model transmitters.

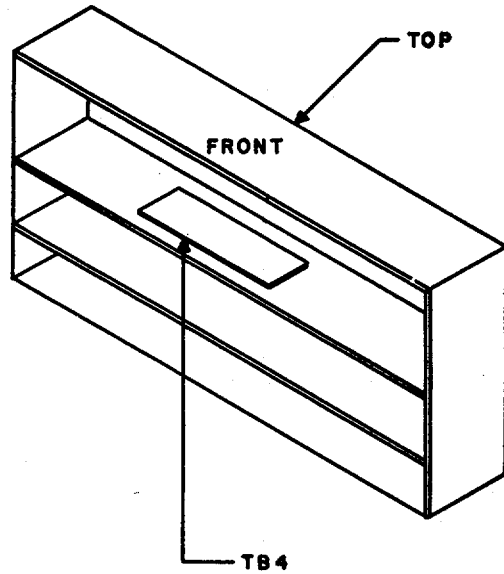
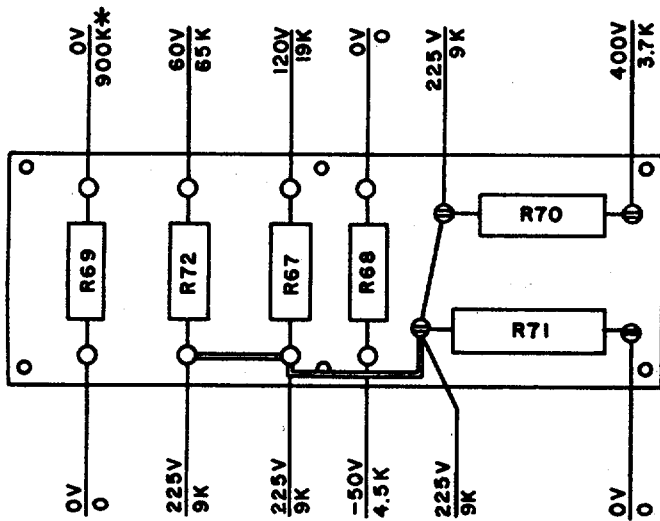

- NOTES:
1. ALL VOLTAGE AND RESISTANCE READINGS MEASURED TO GROUND WITH 20,000 OHMS PER VOLT METER
  2. KEYING SWITCH IN CONTINUOUS POSITION.
  3. \*DEPENDS ON SETTING OF R74.

TM809-35-34

Figure 81. Modulator deck terminal board TB4 voltage and resistance data, B model and C model transmitters on Order No. 43056-Phila-56.

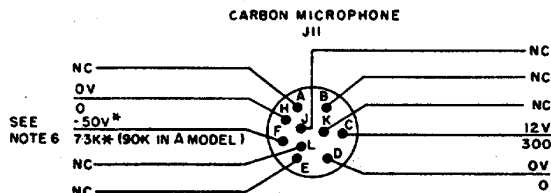

- NOTES:
1. VOLTAGES AND RESISTANCES MEASURED TO GROUND WITH 20,000 OHMS-PER-VOLT METER.
  2. NC INDICATES NO CONNECTION.
  3. VOLTAGE READINGS ABOVE LINE, RESISTANCE READINGS BELOW LINE.
  4. READINGS MADE WITH S6 AND MICROPHONE SWITCH OPEN.
  5. \*IN LETTERED MODELS WITH S1 IN EXT EXC POSITION, 0 OHMS, 0 VOLTS.
  6. IN BASIC MODEL TRANSMITTERS, TERMINAL F IS -35V, 470 OHMS

TM809-35-30

Figure 82. CARBON MICROPHONE jack J11 voltage and resistance data.

### 32. Dc Resistances of Transformers, Coils, Relays, and Meters

#### a. Transformer Windings and Coils

Transformer or coil	Terminals	Ohms
T1	1-3	1.8
	4-6	.16
	7-9	2.1
	10-12	.05
T2	1-3	3.8
	4-6	.05
T3	1-3	1.6
	4-6	60
T4	1-2	1.9
	3-5	135
	6-8	.01
	9-11	.01
T5 (basic, B, and C models).	1-3	370
	4-5	150

Transformer or coil	Terminals	Ohms
T5 (A model)	1-3	220
	4-5	65
T6 (basic, B, and C models).	1-2	450
	4-6	2,200
T6 (A model)	1-2	3,900
	4-5	1,350
	1-3	8,000
T7	1-3	24
	4-6	.28
T8	1-3	13
	4-6	.06
T9 (basic model)	1-3	.12
	4-6	.12
	7-9	110
T9 (A model)	1-4	.12
	5-7	110
T9 (B and C models).	1-2	.12
	3-5	110
T10 (lettered models).	1-2	76
	3-4	90
	5-6	.8
	6-7	.9
	8-9	
	8-10	26
L1	.....	.03
L2	.....	.08
L3	.....	5.5
L4	.....	.08
L5	.....	100
L6	.....	100
L7	.....	100
L8	.....	68
L9 (basic, B, and C models).	.....	40
	.....	18
L9 (A model)	.....	40
L10	.....	40
L11	.....	40
L12	.....	40
L101	.....	.1
L102	.....	.23
L103	.....	.23
L104	.....	.24
L105	.....	.25
L106	.....	.07
L107	.....	.06
L108	.....	.84
L109	.....	.27
L110	.....	.12
L111	.....	.07
L801*	.....	
L802	.....	3.3
L803*	.....	

\* Parts inclosed in sealed containers.

*b. Relay Coils.*

Relay reference symbol	Dc resistance (ohms)	Relay reference symbol	Dc resistance (ohms)
K2	500	K5	400
K4	11	K3	400
K1 (basic model).	300	K1	400
K1 (A model)	220		
K8	400	K101	45
K6	100	K7 (basic, B, and C models)	2000
K9 (B and C models) .	11,000	K7 (A model)	60
K9 (A model)	15,000		
K10 (A model)	9,000		
K10 (Bands C models).	10,000		
K11 (B and C models).	300		

*c. Meter.*

Meter	Dc resistance (ohms)
M1	155.3
M2	3.33
M3	.304

**33. Signal Substitution Notes**

The following information applies to signal substitution and signal tracing in the transmitter:

*a.* An RF signal generator capable of operating over the transmitter frequency range of 1.5 to 20.0 mc is required. When the master oscillator stage is known to be functioning properly, it may be used in place of this test signal generator (in 1.5- 3.0-mc range). An audio oscillator is required to check the modulator portion of the transmitter.

*b.* To measure, observe, or listen to the output of the circuit being tested, a multimeter, an oscilloscope, or a headset, may be used.

*c.* When checking the AF circuits with a headset, note the volume and listen for serious distortion at the various points during the signal substitution procedure.

d. Check the wiring and soldering in each stage during the procedure. Do not remove the shield or can of a tuned circuit (in the multiplier) until trouble has been traced to that part. Do not damage the wiring by pushing it back and forth during the inspection.

e. If one or more stages of the multiplier are not aligned, the output of the transmitter will be absent or reduced.

f. When trouble has been localized to a stage, first

test the tube. Next, measure the resistances in the stage, since this can be done with the power turned off. Finally, measure the voltage at the tube pins. When the resistance of individual parts is being measured, it often is necessary to disconnect one lead of the part to prevent the associated circuit from causing misleading results.

g. Each step presupposes satisfactory completion of all previous steps. Isolate and correct any trouble located before proceeding with succeeding steps.

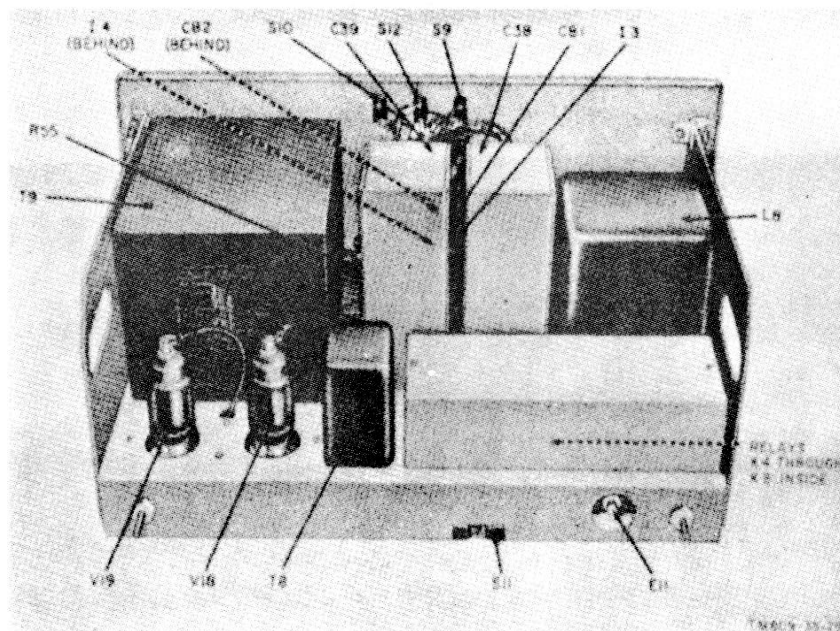

Figure 83. Power supply deck, top view.

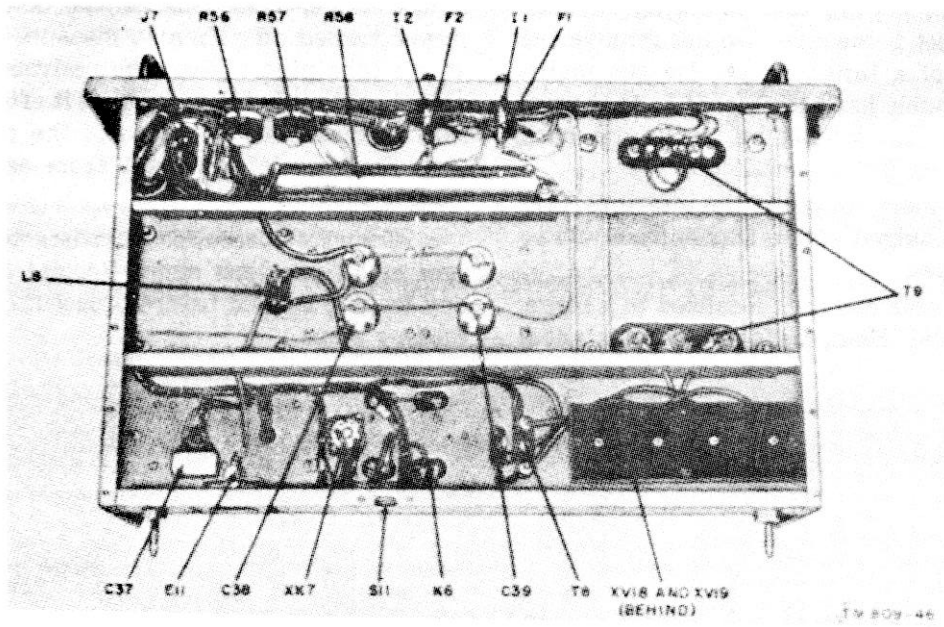

Figure 84. Power supply deck, bottom view.

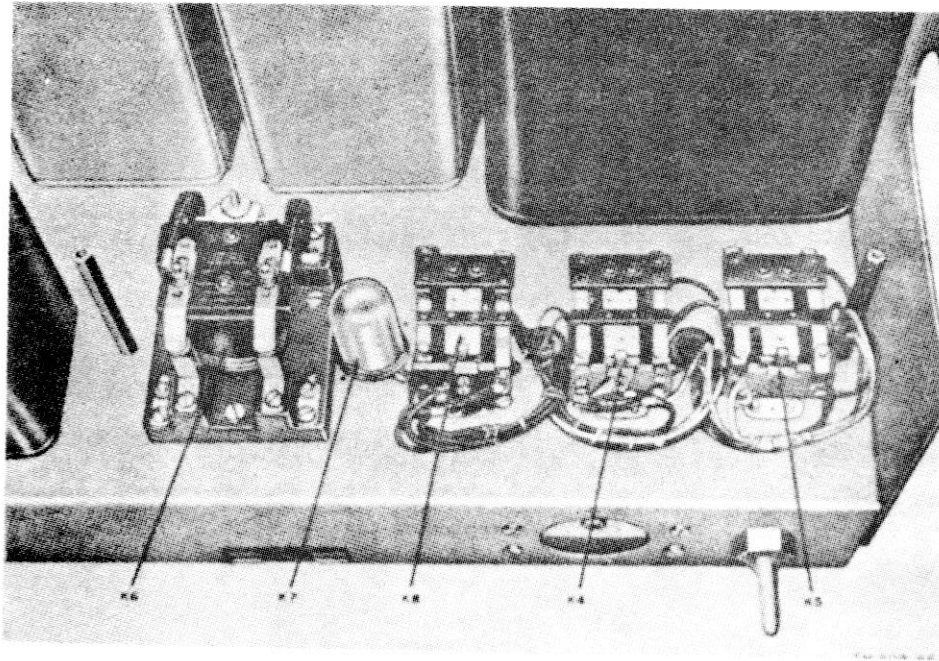
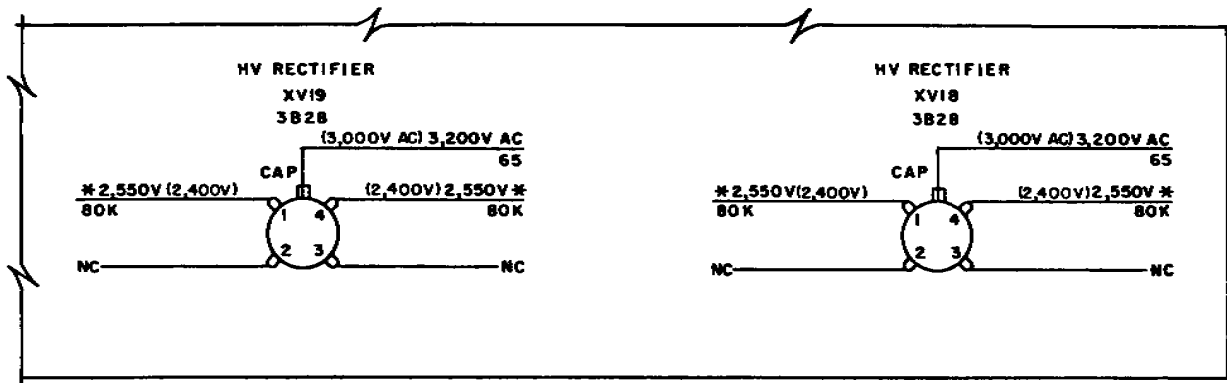

Figure 85. Power supply deck relays.

AGO 2742A



- NOTES:
1. 115VAC INPUT.
  2. SWITCH S12 AT **OPERATE** (**NORMAL** IN A AND C MODEL TRANSMITTERS) AND ALL OTHER SWITCHES AT ON.
  3. VOLTAGES AND RESISTANCES MEASURED TO GROUND WITH 20,000 OHMS-PER-VOLT METER.
  4. \* INDICATES 2.5VAC ACROSS FILAMENTS IN ADDITION TO B+ TO GROUND.
  5. NC INDICATES NO CONNECTION.
  6. VOLTAGE READINGS ABOVE LINE, RESISTANCE READINGS BELOW LINE.
  7. FIGURES IN ( ) ARE FOR BASIC MODEL TRANSMITTERS.

Figure 86. Power supply deck, tube V18 and V19 voltage and resistance data.

### 34. Signal Substitution in Transmitter

#### a. Check of RF Stages.

- (1) Set the EXCITATION METER SWITCH to P A GRID X2, and turf on the transmitter without the high; voltage applied. Set the BAND SELECTOR switch to the proper range, and inject a test signal (3 to 5 volts) into the control grid (pin 1) of V104. The absence of any output (PA GRID X2 reading at zero) indicates the possibility of a defective tube. Check the tube on a tube tester. Also check the cathode (pin 3) voltage; this pin should read 0 volts for all modes of operation except EXT EXC. An abnormally high reading under the latter condition may be caused by a burned out cathode resistor (R121). The presence of a reading on some bands and none on others indicates trouble in the tuned circuits; check tuned circuits Z107, Z108, Z109, and Z110. The resistance of the coils in these circuits can be checked against the values given in paragraph 32.
- (2) Turn the BAND SELECTOR switch to the 12.0-20.0 position. At this setting, all three multiplier stages are functioning. Connect the RF signal

generator to jack J101 if the output of the oscillator is not to be used. A minimum reading of 8 ma on the EXCITATION meter at PA GRID X2 position shows these stages to be working. If no reading is obtained, one multiplier stage is defective. Connect a multimeter to the control grid (pin 1) of the second multiplier, V102. The absence of negative do voltage at the control grid of V102 indicates trouble in the V101 stage or in interstage circuitry, possibly in capacitor C108 or tuned network Z102. Repeat this check at the control grids of V103 and V104. If necessary, the signal generator can be disconnected from the input to the first stage and connected to the input of the stage in question. Inject a signal of 1.5 to 3 mc into the control grid (pin 1) of first buffer tube V801. This stage can be checked by reading a negative do voltage at the control grid (pin 1) of second buffer tube V101 or by setting the BAND SELECTOR switch to its lowest range and obtaining a reading on the EXCITATION meter (PA GRID X2 position of EXCITATION METER SWITCH). The master oscillator can be checked

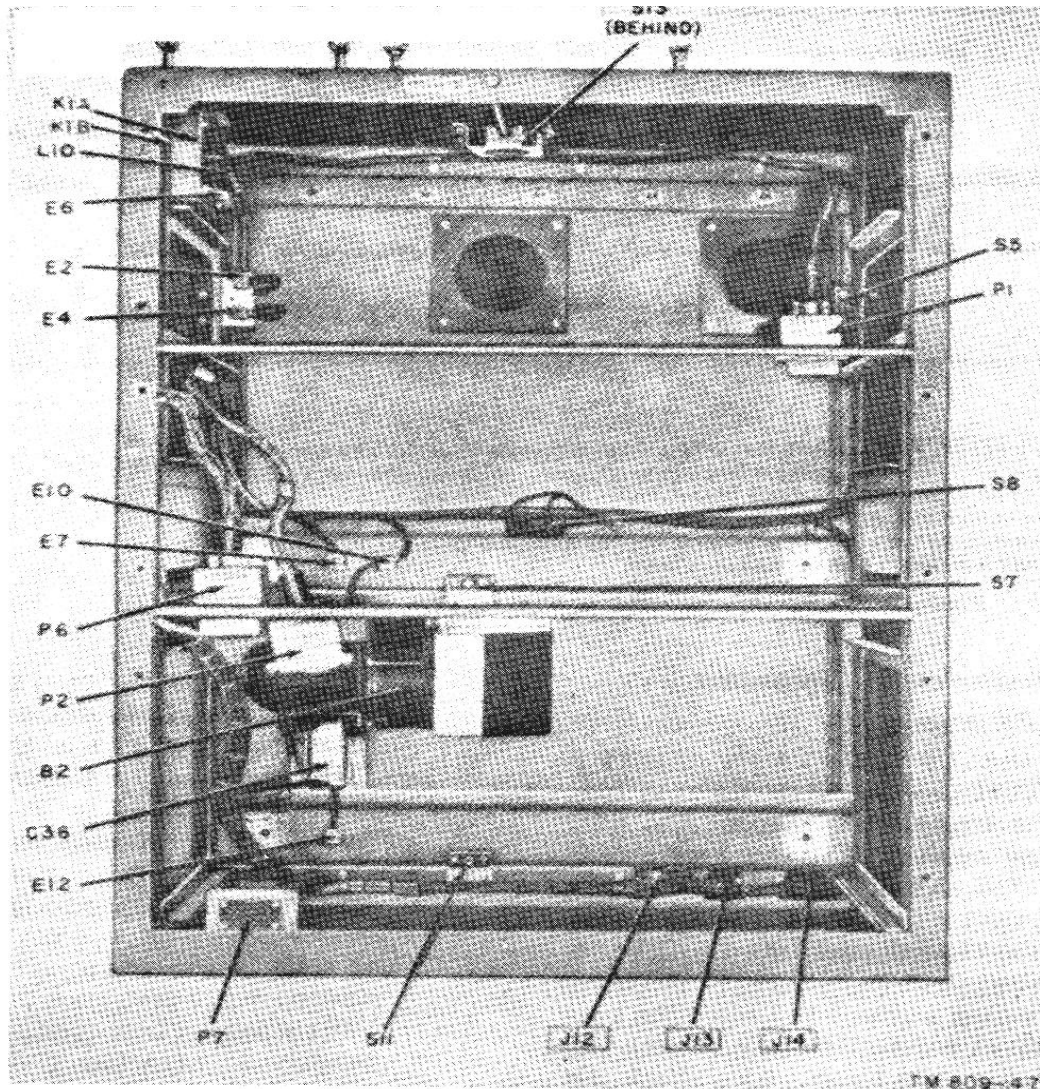

Figure 87. Transmitter housing, decks removed, basic model transmitters.

by noting a negative dc voltage at the control grid of either V802 or V101 or a current reading on the EXCITATION meter. The individual stages can also be checked as described in the troubleshooting chart.

- (3) The pa stage can be checked by the meters on the transmitter. The grid circuit is normal when a minimum of 8 ma (a maximum of approximately 12 ma) is read on the EXCITATION meter at PA GRID X2 position of the EXCITATION METER SWITCH. A signal should be applied to the ipa grid

either by using an outside signal source or the mo of the transmitter. When checking the plate circuit, always place the TUNE-OPERATE switch (TUNE-NORMAL switch in A model and certain C model transmitters) at TUNE before applying high voltage to the equipment. A minimum value of current seen on the PA PLATE meter indicates a normal condition in the plate circuit when tuning through resonance with the POWER AMPLIFIER TUNING control. The plate current should rise sharply to a

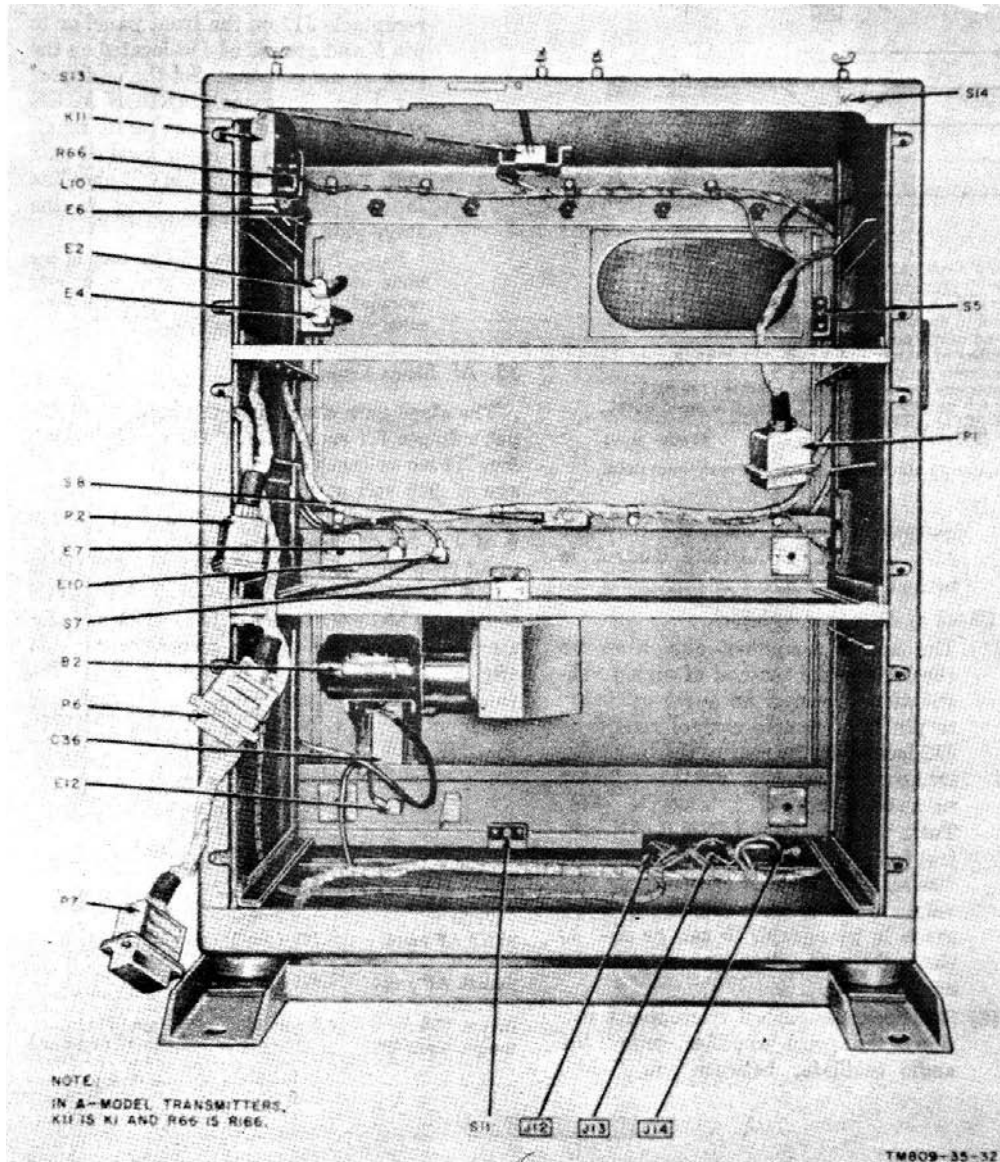
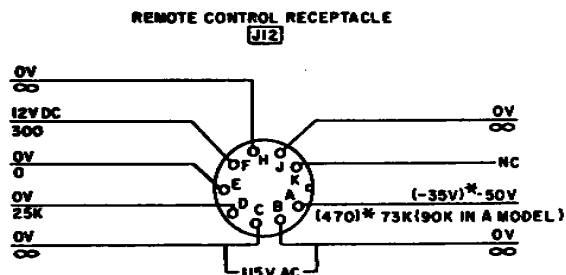

Figure 88. Transmitter housing, deck removed, lettered model transmitters.





- NOTES:**
1. 115VAC INPUT TO POWER SOCKET **J14**
  2. SERVICE SELECTOR SWITCH AT **FSK**
  3. VOLTAGES AND RESISTANCES MEASURED TO GROUND WITH 20,000 OHMS-PER-VOLT METER.
  4. NC INDICATES NO CONNECTIONS.
  5. VOLTAGE READINGS ABOVE LINE, RESISTANCE READINGS BELOW LINE.
  6. \* READINGS FOR BASIC MODEL TRANSMITTER IN ( ).
  7. SWITCH S6 (EXCITER PLATE POWER) IN BASIC MODEL, **KEYING** IN LETTERED MODELS) OPEN.

Figure 89. Jack J12 voltage and resistance data.

normal indication when the POWER AMPLIFIER LOADING control is turned to the correct setting.

b. Check of Speech Amplifier.

- (1) The speech amplifier can also be checked by the method of signal substitution. Connect an audio oscillator to pin D of remote control receptacle J12 located at the rear of the transmitter housing (fig. 87). Set the oscillator to a frequency of 1 kilocycle (kc). Turn the 600 OHM LINE GAIN control fully clockwise for maximum gain. Use an input level of .015 volt. If this value is used, the stage-gain chart given in paragraph 36 can be used to check the grid, plate, and output voltages.
- (2) To check the carbon microphone section of the speech amplifier, connect the audio oscillator between pin C and

ground on CARBON MICROPHONE receptacle J11 on the front panel or to pin F and ground of J12 located on the rear of the housing. Set the oscillator for 1 kc. Turn the CARBON MIKE GAIN control fully clockwise for maximum gain. Use an input level of .028 volt. As in the case of the 600mhm line input described above, refer to the stage-gain chart.

Note. Turn the gain control that is not being used fully counterclockwise to prevent extraneous signals from affecting the operation of the speech amplifier.

### 35. AF Stage-Gain Chart

The stage-gain chart lists the input and output voltages for each stage of the speech amplifier. These voltages are based on an input voltage of .015 volt at pin D of J12 for a 600-ohm line input and of .028 volt at pin C of J11 or pin F of J12 for carbon-microphone input. Use an input frequency of 1 kc. Set either the 600 OHM LINE GAIN and the CARBON MIKE GAIN control (whichever is used) fully clockwise for maximum gain. Set clipper potentiometer R44 (fig. 69) to off (fully counterclockwise). The values of V13, V15, and T6 were obtained with the input at pin C of J11 (CARBON MICROPHONE input).

Stage	Input (volt)	Output (volts)
First AF ampl V12A	.016 (pin 2)	.108 (pin 1).
Second AF ampl V12B	.028 (pin 7)	.122 (pin 6).
Third AF ampl VI3A	.125 (pin 2)	1.12 (pin 1).
Fourth AF ampl V13B	.675 (pin 7)	6.5 (pin 6).
Driver V16	6-5 (pin 6)	72 (pins 1, 6).
Output bans T6	_____	80 (terminals 4 or 6 to 6).

## CHAPTER 3

### REPAIRS, ALIGNMENT, AND FINAL TESTING

---

#### Section I. REPAIRS

#### 36. Replacement of Parts

Most of the parts in the transmitter are readily accessible and are easily replaced if necessary. When a large number of leads are being disconnected from a part to be replaced, the rewiring time can be shortened and the process will be accurate if the leads are marked with identification tags.

#### 37. Removal of Subassemblies

**Caution:** Do not try to pull any of the decks out more than about 4 inches without first disconnecting the cabling in the housing. Some of these cables become taut when a deck is pulled out more than 4 inches and may become damaged. Disconnect the cables that prevent complete removal of the deck. Because the main blower is mounted on the rear panel, the panel has a tendency to slide downward when being removed. This may damage the interlock switches. Be careful not to let the rear panel slip during removal.

*a. Removal of Speech Amplifier Subassembly* (figs. 60 and 69).

- (1) To gain access to the speech amplifier subassembly, remove the modulator deck from the equipment housing. An alternate procedure is to leave the deck in place and remove only the back panel.
- (2) Remove all electrical connections to the subassembly. Disconnect plugs P3, P4, and P5 from their respective receptacles J3, J4, and J5 on the chassis.
- (3) Loosen the four Camloc fasteners that hold the subassembly to the modulator deck. The speech amplifier subassembly can now be removed.

*b. Removal of Oscillator and Multiplier Subassemblies* (figs. 39 and 48).

- (1) Remove the four screws that fasten the assembly to the front panel of the RF deck.
- (2) Disconnect plug P101 from receptacle J8 on the deck, and disconnect coaxial plugs P8, P9, P10, and P801 from jacks J101, J102, J103, and J104 on the multiplier subassembly. The assembly can now be withdrawn from the RF deck.

*c. Removal of Multiplier Subassembly.*

- (1) Set the equipment to 3 mc by turning the BAND SELECTOR control to 1.5-3.0 and turning the TUNING CONTROL until the mechanical counter indicates 3,000.
- (2) Insert a ¼-inch diameter metal rod through the appropriate holes in the cams. Insert the rod from the back and through the slotted portion of the end plates.
- (3) Remove the three cable clamps that hold the cable harness of plug P101.
- (4) Unsolder the three leads from the three feed through terminals on the mounting bracket at the back of the oscillator subassembly. Tag the leads for reconnection.
- (5) Loosen the four captive screws on the subassembly. Access to one of these screws at the back is through the top of the subassembly.
- (6) Remove the subassembly by lifting it up and out. *Note.* Note the positions of the flexible couplings for the band switch and the camshaft with the equipment set for 3 mc. The two shafts can be coupled at either their correct setting or one 180° away; erroneous operation can result if they are coupled incorrectly.

d. *Removal of Oscillator Subassembly.*

- (1) Disconnect plug P802 from receptacle J106 on the rear mounting bracket, and disconnect plug P801 from jack J101 on the multiplier subassembly.
- (2) Loosen the setscrews of the scissor gears (fig. 91) on the oscillator drive shaft.
- (3) While supporting the subassembly, remove the three screws that fasten the subassembly to the gear plate.
- (4) Still supporting the subassembly, loosen the two screws that fasten the rear mounting bracket to the bracket on the bottom plate. (As the latter bracket uses slotted holes, these screws need only be loosened and not completely removed.) The subassembly can now be removed.

*Note.* The scissor gears detached from the oscillator drive shaft may be removed and replaced if necessary.

### 38. Disassembly of Drive Mechanisms

a. *Disassembly of Oscillator-Multiplier Tuning Drive Mechanism* (figs. 31, 90, 91, and 92).

*Note.* For easier servicing of the tuning drive mechanism, first remove the multiplier and oscillator subassemblies by following the procedures given in paragraph 37.

- (1) Remove the BAND SELECTOR and TUNING CONTROL knobs after loosening their setscrews. Detach the bearing plate behind the TUNING CONTROL knob by removing the two screws that attach the plate to the front panel.
- (2) Remove the front panel by removing the five screws that hold the panel in place.
- (3) Remove the mechanical counter assembly by removing the four screws that fasten the assembly to the gear plate. One of the lower corners is positioned by a locating pin; remove the assembly with a forward motion to clear the pin.
- (4) Loosen the hub clamp on the exciter drive gear (behind the gear plate). Similarly loosen the hub clamp on the oscillator drive gear, which is next to and on the sac shaft as the exciter drive gear. Slide both gears off their

shaft. Withdraw the shaft together with the counter drive gear. Remove this gear from the shaft by loosening its hub clamp. If necessary to facilitate disassembly, unfasten the bearing plate from the gear plate.

- (5) Remove the counter drive idler gear by removing its retainer ring.
- (6) Remove the exciter drive idler gear (behind the gear plate) by removing its retainer ring.
- (7) Remove the exciter camshaft gear (behind the gear plate) by removing its retainer ring (in front of the gear plate).
- (8) Remove the band switch idler gear (behind the gear plate) by removing its retainer ring (in front of the gear plate).
- (9) Remove the band switch drive gear (behind the gear plate) by loosening its hub clamp.
- (10) To gain access to the cam on the BAND SELECTOR shaft, remove the three screws that hold the detent assembly to the gear plate. Depress the lever arm by hand and slide the cam and shaft out; if desired, disconnect the spring between the lever arm and the gear plate. The cam is pinned to the shaft. To detach the lever arm, remove the retainer ring that holds the lever arm to its shaft.
- (11) To remove the cam followers and guides on the multiplier tuning mechanism, first disconnect the two springs that hold the rack down.

**Caution: When handling the rack, be careful not to damage the tuning slugs or bend their adjustment screws.**

- (12) The rack is now free to be lifted clear of the multiplier. To remove the rack guide at each end of the rack, remove the retainer ring at the end of the shaft that mounts the follower and guide. To detach the shaft from the rack, remove the screw (under the rack) that holds the two parts together. The cam follower can now be slid off its shaft.
- (13) To remove the cams on the multiplier tuning mechanism, remove the retainer ring at the back end of the camshaft.

Slide the shaft forward and remove the two retainer rings and the two washers. To remove the cams, force the pins out of the cam hubs and slide the cams off the shaft.

*b. Disassembly of Power Amplifier Tuning Drive Mechanism (figs. 32 and 93) .*

- (1) To disassemble the power amplifier tuning drive mechanism, remove it in one piece from the RF deck. Disconnect the flexible couplings to the tuning and loading capacitors (C6 and C9). To unfasten the assembly from the deck front panel, remove the four screws.
- (2) Remove the gear that is normally coupled to the tuning capacitor (C6). The gear is fastened to its shaft by both a setscrew and a pin. Loosen the setscrew and remove the pin.
- (3) Remove the idler gear by removing its retainer ring.
- (4) Remove the gear on the POWER AMPLIFIER TUNING shaft by loosening its setscrew and removing its pin.
- (5) Remove the bevel gear on the POWER AMPLIFIER TUNING shaft by loosening its setscrew and removing its pin. Slide the shaft forward until the gear becomes free.
- (6) Remove the bevel gear on the shaft of the tuning drive stop by loosening its setscrew and removing its pin. If necessary, loosen the setscrew on the mechanical counter bevel gear and slide it back on its shaft to give the first gear clearance.
- (7) Remove the bevel gear on the shaft of the mechanical counter by loosening its setscrew.
- (8) To disassemble the tuning drive stop, loosen the setscrew and remove the pin from the stop collar. Slide the shaft out. Remove the flat washer at the bottom next to the stop pin, the five shims in succession, and alternately remove the 27 stop washers and 26 shims.
- (9) To disassemble the bevel gears associated with the POWER AMPLIFIER LOADING control, remove the retainer ring from the shaft and follow

a procedure similar to that for the POWER AMPLIFIER TUNING control ((5)-(7) above).

- (10) To disassemble the loading drive stop, follow a procedure similar to that for the tuning drive stop ( (8) above). For this stop, there are a flat washer, five shims in succession, and alternately, 33 stop washers and 32 shims.

### **39. Reassembly of Drive Mechanisms**

Reassembly is essentially the reverse of the disassembly procedure previously given. Observe the following points during reassembly:

*a. Reassembly of Oscillator-Multiplier Tuning Drive Mechanism (fig. 31) .*

- (1) When reassembling the cam assembly, slide the cams back over their shaft. The front surfaces of each cam should be 6 15/16-inches apart. Slide the 1/4-inch metal rod through the cams and the slots in the end plates of the multiplier subassembly. With the cams so positioned, replace the pins that fasten the cams to their shaft. Make certain that the hub end of the back cam is aligned with the edge of the inner retainer ring groove on the shaft.
- (2) When replacing the two flat washers and two retainer rings- at the back end of the camshaft, make certain that the washers are *between*, the retainer rings. The end slots of the movable rack fit between the two washers and are positioned by them.
- (3) When replacing the oscillator drive gear, be sure to replace the two flat washers onto the tuning control shaft, between the bearing plate and the oscillator drive gear. These washers correctly locate the oscillator drive gear on its shaft and, therefore, they are in the proper position with respect to the oscillator drive shaft (scissors) gear. After reassembly, the oscillator drive gear hub coupling is left loose to permit manual adjustment of the tuning drive mechanism (par. 41).

*b. Reassembly of Power Amplifier Tuning Drive Mechanism.*

- (1) Make certain that the flat washer, shims, and stop washers on each mechanical stop are replaced in the order indicated in the disassembly procedure.
- (2) Leave the bevel gears on the shafts of the mechanical counters loose to permit adjustment (par. 43).

#### 40. Replacement of Subassemblies

Replacement is essentially the reverse of the removal procedures previously given. Observe the following points during replacement:

*a. Replacement of Oscillator Subassembly.* When replacing the oscillator drive shaft (scissors) gear, offset the teeth on one gear with respect to the other gear by one or two teeth. The amount of offset should give no binding while still reducing backlash to a minimum.

*b. Replacement of Multiplier Subassembly.*

- (1) If the 1/4-inch diameter metal rod has been removed from the holes through the cams, replace the rod. This positions the cams and the rack at their highest position.
- (2) Reconnect the three wires in the cable harness to the three feed through terminals on the bracket at the back of the oscillator subassembly.
- (3) Make certain that the two couplings are in the sac position as at the start of the equipment disassembly. As described in paragraph 37 *c* (removal procedure for the multiplier subassembly) it should be coupled to the drive mechanism with the BAND SELECTOR at 1.5-3.0 and the mechanical counters indicating 3.000; the cams should be locked with the metal rod as mentioned in (1) above.

#### 41. Oscillator-Multiplier and Power Amplifier Tuning Drive Adjustments

*a.* To adjust the oscillator-multiplier tuning drive mechanism (fig. 31), proceed as follows. Turn the SERVICE SELECTOR switch to the AM position. Set the transmitter for 1.5 mc operation by turning the BAND SELECTOR switch to 1.5-3.0 and by turning the TUNING CONTROL until 1.5 mc is indicated on a fre-

quency meter connected to the transmitter. Make the setting as close to 1.5 mc as the accuracy of the measuring equipment will allow. If the counters do not indicate this frequency, they will have to be reset while maintaining the setting of the oscillator. To do this, loosen the oscillator drive gear by loosening its hub clamp on the shaft of the oscillator assembly so that the gear will turn freely without affecting the oscillator frequency. Now move the gear train until the counters indicate the desired frequency. When this is done, refasten the loose gear to the oscillator shaft. Repeat this procedure at the 3.0 mc setting (on the 1.5 to 3.0 mc band) as a check.

*b.* If the power amplifier tuning drive mechanism (fig. 32) has to be disconnected from the two counters, the counters will have to be reset. First loosen the bevel gear on the shaft of the counter, and then turn the drive shafts to their extreme clockwise positions. Set the counters to their zero settings, and recouple the bevel gear to the countershaft.

#### 42. Servicing Antenna Tuning Unit BC-939-B

(figs. 94 and 95)

All components of the tuning unit are easily removed and replaced when repair or replacement is necessary. Be careful when handling the vacuum capacitors and ceramic parts because excessive pressure will damage them. To service the tuning unit, proceed as follows:

*a.* Remove the antenna connecting wire from the rear binding post of the unit. Disconnect the coaxial cable from the transmitter RF OUTPUT jack at the ground and RF input terminals of the antenna tuning unit.

*b.* Remove four wingnuts that secure the unit to the top of the transmitter. Lift the unit from the transmitter to the repair space.

*c.* Remove the cover of the unit by releasing the four catch assemblies along the bottom edge and lifting it free.

*d.* Carefully remove the two vacuum capacitors from the spring clip connectors and put them in a safe place.

*e.* Remove the ANTENNA CURRENT meter as follows:

- (1) Disconnect the wires from the meter.
- (2) Remove the two mounting screws and nuts.

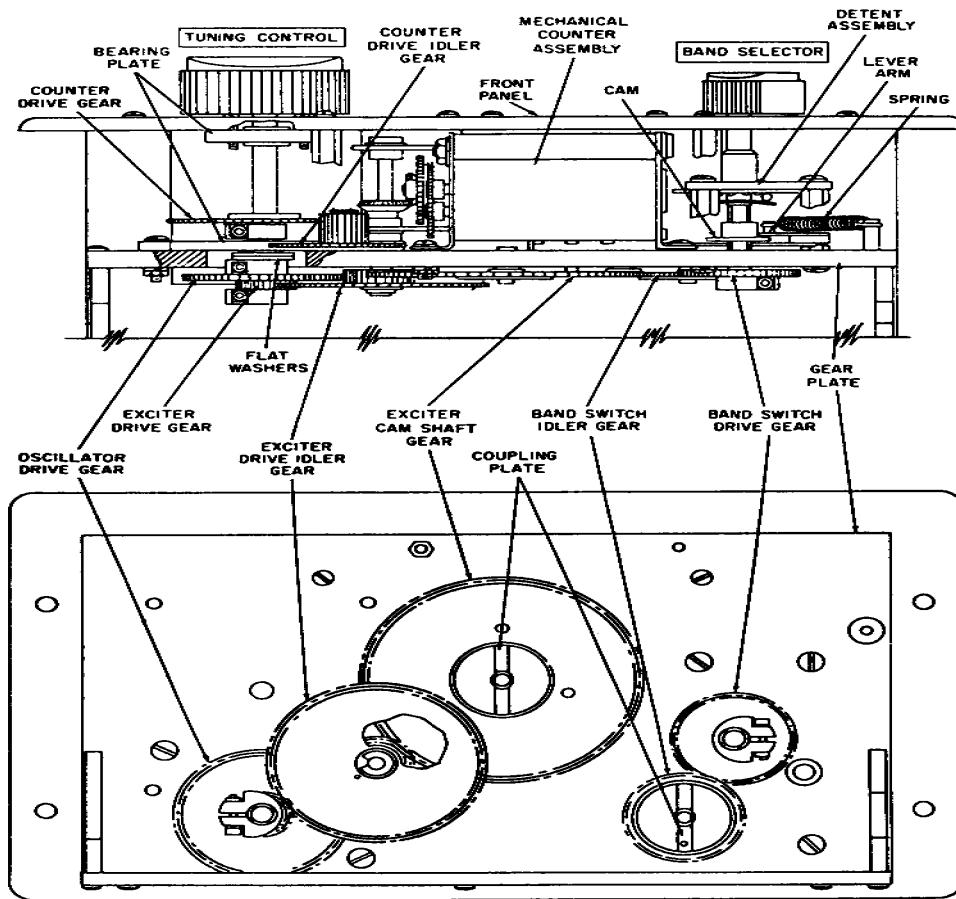

Figure 90. Oscillator-multiplier tuning drive, gear assembly.

- (3) Hold the meter and remove the last (third) mounting screw and nut.
- (4) Remove the meter from the front panel.
- (5) To replace, reverse the order of the removal procedure.

f. Replace the glass rod which supports the contact shoe for inductor L6 as explained below.

- (1) To remove the glass rod, proceed as follows:

- (a) Remove the screws and nuts that secure the two phenolic blocks to the ceramic ends.

*Note.* Fiber shims may be in the large holes of phenolic blocks. These shims (if used) take up the length that is left by rod and end tolerances. Do not lose these shims. It will be necessary to use some or all of them when installing the new rod.

- (b) Slide the rod through the contact shoe bearing.

AGO 2742A

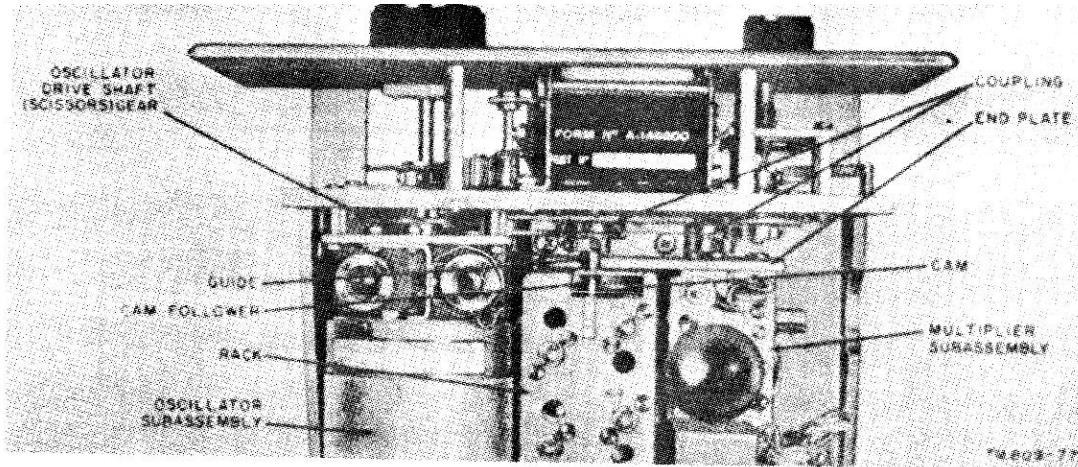

Figure 91. Oscillator-multiplier tuning drive, top view.

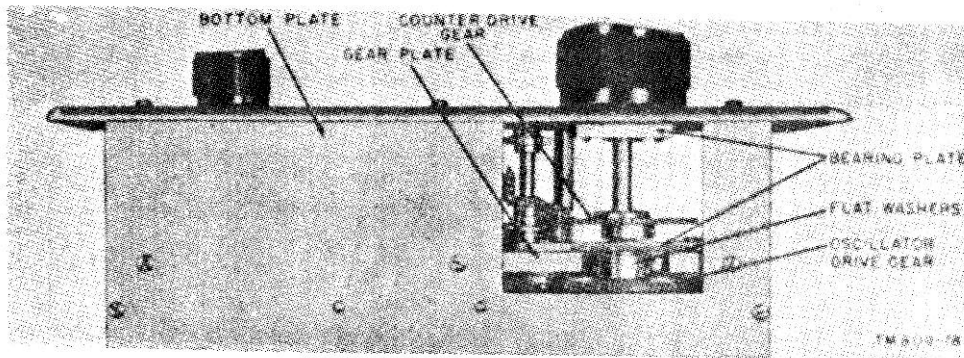

Figure 92. Oscillator-multiplier tuning drive, view through bottom plate.

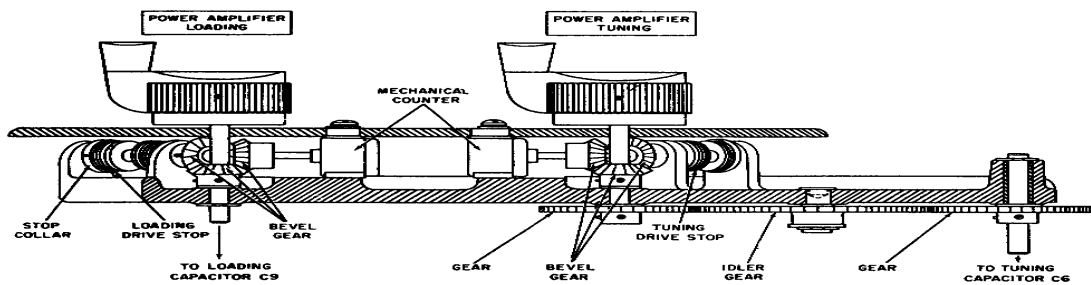

Figure 93. Power amplifier tuning drive, gear assembly.

TM 809-79

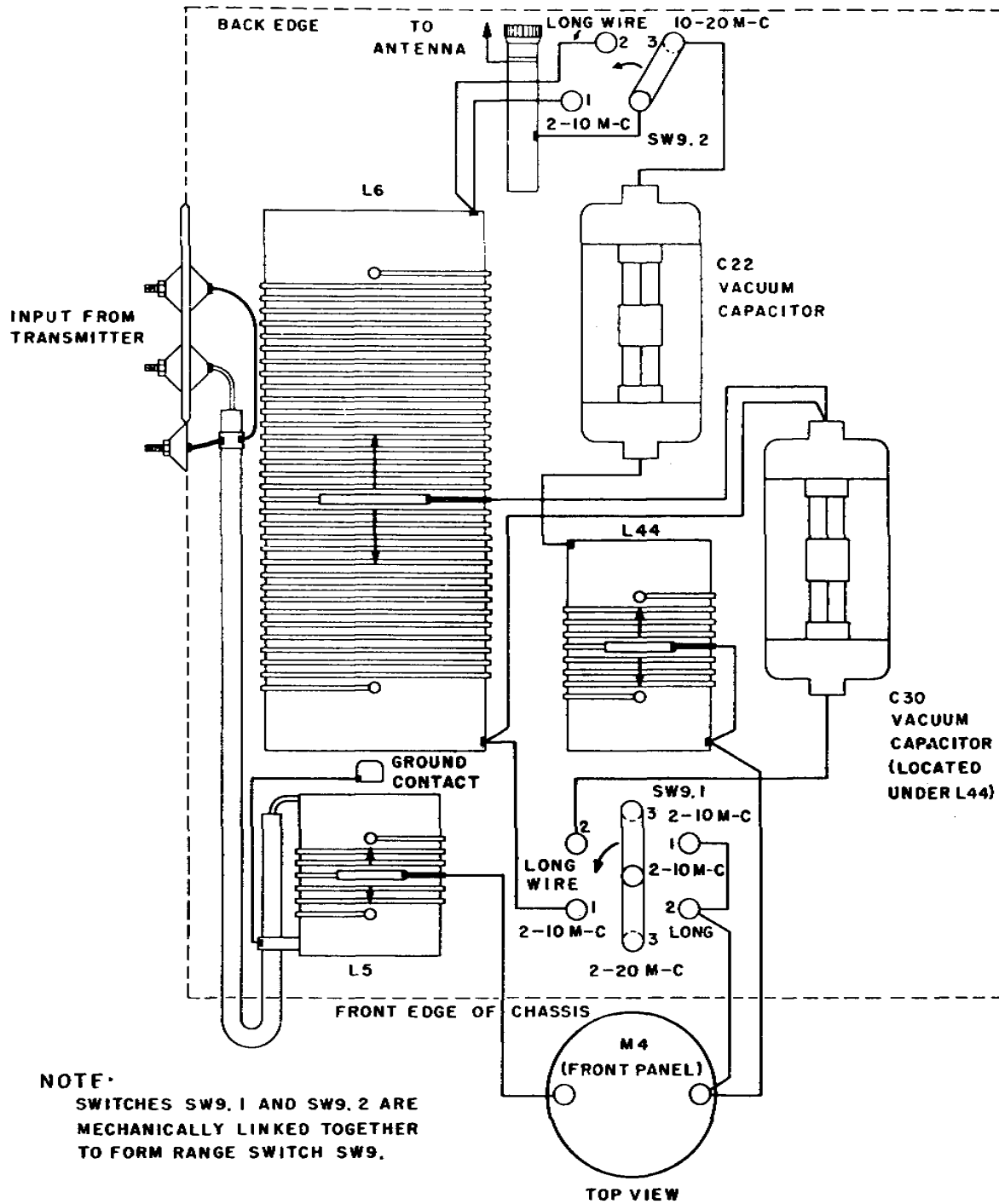

Figure 94. Antenna tuning unit, practical wiring diagram.

TM 809-89

AGO 2742A



- (2) To replace the glass rod, proceed as follows:
- Try the rod between the ceramic end plates to be sure that it fits and also to find the number of fiber shims necessary, if any.
  - Insert the rod through the contact shoe.
  - Rotate the FREQUENCY control crank clockwise until three zeros appear on the indicator.
  - Position the adjustable contact shoe to the front turn of the inductor.
  - Secure the rear phenolic block (glass rod mounted) to the ceramic end with screws and nuts.
  - While holding the front phenolic block in place , rotate the FRE-

QUENCY control crank counterclockwise, moving the adjustable shoe to the rear turn. Be sure that the motion is free and that the shoe is following the inductor windings.

- Secure the front phenolic block (glass rod mounted) to the ceramic end with screws and nuts.
  - Rotate the FREQUENCY control crank to check operation again.
- g. To remove inductors, proceed as follows:
- For L44, remove the two screws and elastic stop nuts from the angle brackets which secure the phenolic base of inductor L44 and vacuum capacitor C22.
  - Loosen the two setscrews on the induc-

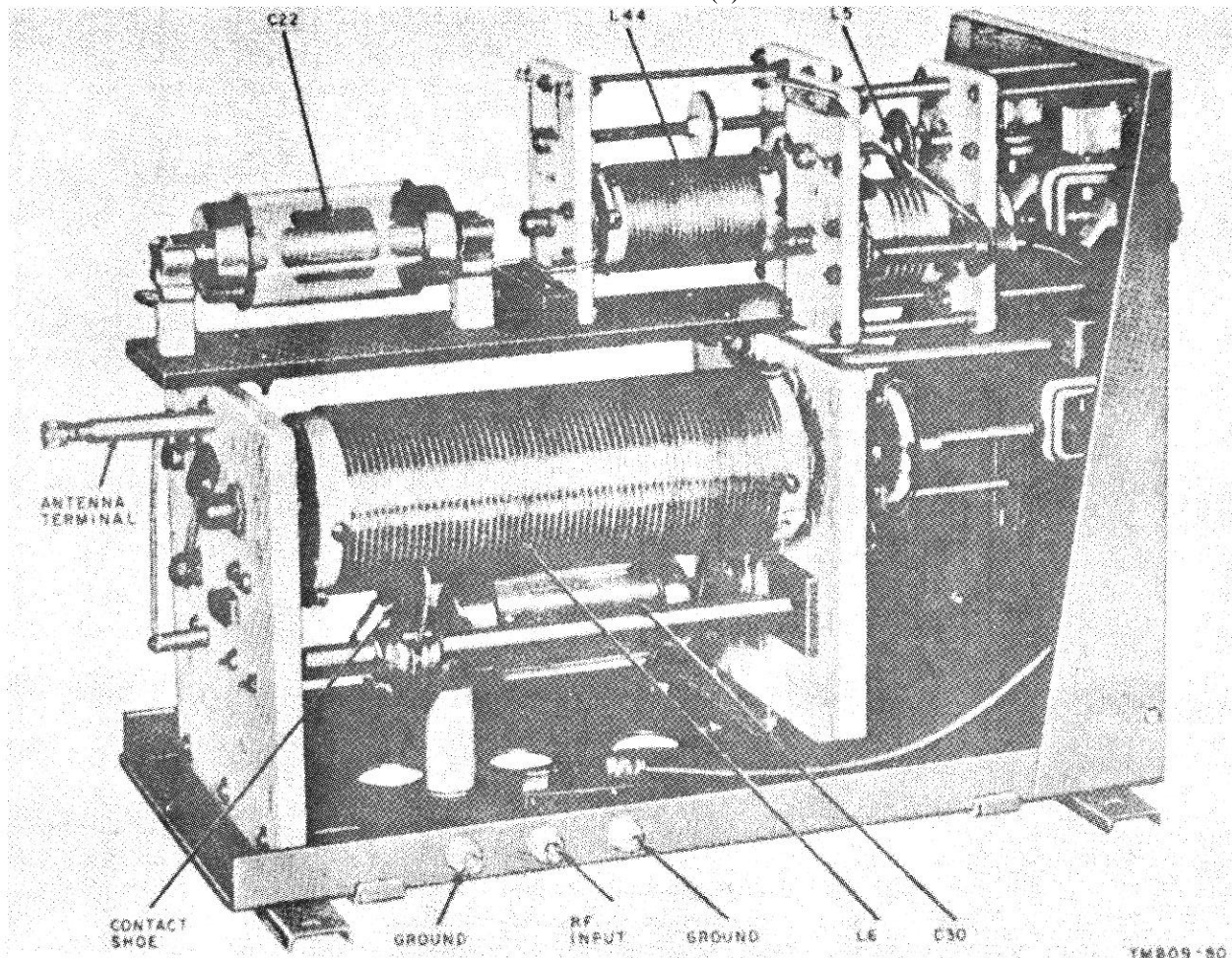

Figure 95. Antenna tuning unit BC-939-B cover removed.

TM 809-80

tor side of the FREQUENCY control flexible coupling.

- (3) Loosen the Allen setscrew in the rear shaft collar and remove the collar.
- (4) Remove the screw and nut from the rear switch extension shaft.
- (5) Remove the three screws and elastic stop nuts that secure the ceramic end plate to the phenolic base strip.
- (6) Hold the glass rod and gently pull the ceramic end plate free of the inductor through the shaft.
- (7) To replace, reverse the removal procedure and align the movable contact shoe as described in *f* above

*h.* The same general disassembly and assembly instructions apply to inductors L5, L6, and L44. Although some items do not apply, the maintenance procedure is quite simple and the same care should be exercised in handling. The COUPLING control rotates counterclockwise to bring the movable shoe to the front winding and the indicator to zero.

*i.* Servicing of the range switch (2-10 M-C LONG WIRE 10-20 M-C) is usually a matter of adjusting the spring contact pressure. This can be done without removing any parts. Work carefully and do not put sharp bends in the spring contacts. Clean the contacts with very fine sandpaper, then brush them clean.

## Section II. ALINEMENT PROCEDURES AND FINAL TESTING

### 43. Alinement of Multiplier Subassembly (fig. 49)

- a.* With the PLATE POWER circuit breaker set at OFF, set the BAND SELECTOR switch to 1.5-3.0 and turn the TUNING CONTROL until 1.5 mc is registered on the counters. Check the output frequency with the frequency meter to determine if the oscillator is operating on 1.5 mc. If the two frequencies do not agree (zero beat), adjust the oscillator drive mechanism as described in paragraph 41. Also check the output frequency at 3.0 mc.
- b.* Set the TUNING CONTROL for 1.55 mc. Turn the EXCITATION METER SWITCH to P A GRID X2. Adjust capacitor C136 in Z107 for maximum reading on the EXCITATION meter.
- c.* Set the BAND SELECTOR switch to 3.0-6.0 while keeping the TUNING CONTROL at its previous setting. Adjust capacitors C109 (in Z101), C112 (in Z102), and C138 (in Z108) for maximum P A GRID X2 reading.
- d.* Set the BAND SELECTOR switch to 6.0-12.0 while keeping the TUNING CONTROL at its previous setting. Adjust capacitors C118 (in Z103), C123 (in Z104), and C140 (in Z109) for maximum P A GRID X2 reading.
- e.* Set the BAND SELECTOR switch to 12.0-20.0 while keeping the TUNING CONTROL at its previous setting. Adjust capacitors C128 (in Z105), C131 (in Z106), and C141 (in Z110) for maximum P A GRID X2 reading.
- f.* Return the BAND SELECTOR switch to 1.5-3.0 and turn the TUNING CONTROL for a frequency of 2.9 mc. Adjust the tuning slug of coil L108 (in Z107) for maximum P A GRID X2 reading.
- g.* Set the BAND SELECTOR switch to 3.0-6.0, while keeping the TUNING CONTROL at its previous setting. Adjust the tuning slugs of coils L102 (in Z101), L103 (in Z102), and L109 (in Z108) for maximum P A GRID X2 reading.
- h.* Set the BAND SELECTOR switch to 6.0-12.0 while keeping the TUNING CONTROL at its previous setting. Adjust the tuning slugs of coils L104 (in Z103), L105 (in Z104), and L110 (in Z109) for maximum P A GRID X2 reading.
- i.* Set the BAND SELECTOR switch to 12.0-20.0, and set the TUNING CONTROL at 20 mc. Adjust the tuning slugs of coils L106 (in Z105), L107 (in Z106), and L111 (in Z110) for maximum P A GRID X2 reading.
- j.* If necessary, repeat the procedures given in *d*, *e*, *h*, and *i* above until no further tuning of the adjustable coils and capacitors is required to give a maximum P A GRID X2 reading.

*Note.* The above procedure is usually satisfactory for the alinement of all circuits on bands 1 and 2 (1.-3.0 and 3.0-6.0) and for the multiplier stages on bands 3 and 4 (6.0-12.0 and 12.0-20.0). The tuning of Z109 on bands 3 and 4, and Z110 on band 4 may require repeating to get maximum grid current.
- k.* Check the overall tracking characteristic of

the multiplier. Connect a multimeter through a 150K resistor to the control grid (pin 1) of V-104 and ground. The meter should indicate a minimum reading of 10 volts (do).

l. Set the BAND SELECTOR switch to either 6.0-12.0 or 12.0-20.0. If the equipment is operating properly, the P A GRID X2 reading should be over 10 ma for all frequencies and should drop to 10 ma or slightly below (but not below 8 ma, with the power amplifier fully loaded) at the extremes of the band.

*Note.* If either slug in Z109 or Z110 is too far in the coil form, the response at a frequency near the band midpoint will be low. To correct this condition, withdraw the slug of the adjusting screw 1 turn at a time and retune capacitor C140 (in Z109) for maximum output when the TUNING CONTROL is set to approximately 9.5 mc (BAND SELECTOR at 6.0-12.0) and 15.5 mc (BAND SELECTOR at 12.0-20.0). Recheck the response. Withdrawing the slug and retuning at midband has the effect of decreasing the circuit bandwidth while increasing the response near midband. Adjusting the slug to start farther in the coil form will extend the band edge response while possible decreasing the midband response.

#### 44. Purpose of Final Testing

Paragraphs 45 through 56 are intended as a guide to be used in determining the quality of a repaired transmitter. A repaired transmitter that meets these requirements will provide satisfactory operation, equivalent to that of new equipment.

#### 45. Equipment Necessary for Final Testing

Test equipment for final testing includes those items listed in paragraph 27 for troubleshooting together with the equipment listed below.

##### a. Test Instruments.

Nomenclature	Common name
RF Ammeter IS-76	RF Ammeter
Wattmeter AN/URM 86	Wattmeter
Spectrum Analyzer TS-723/U	Spectrum analyzer U.
Electronic Multimeter MC-30A/U	Vtvm.
Test Set 100-A	Dot keyer

##### b. Other Equipment.

Two-foot length of #14 soft copper wire  
 Test, Prod Stock No. 3F3705-12.19

Dc ammeter, 0-1 ampere range  
 Adjustable resistor 5,900 ohms, 1,500 watts  
 600-ohm, noninductive resistor, 1 watt  
 200-ohm, noninductive resistor, 1 watt  
 Special Purpose Cable Assembly CX-1852/U  
 Radio Receiver R-390/URR or equivalent  
 Frequency Shift Exciter O-39/TRA-7 or equivalent.  
 Teletypewriter TT-4A/TG or equivalent  
 Control Unit C-292/TRA-7 or equivalent  
 Headset

#### 46. Overload Relay Adjustment

**Caution: Do not reset the OVERLOAD RELAY ADJUS1-IENT controls unnecessarily. Both controls are initially preset at the factory. Do not arbitrarily set them in the maximum clockwise position because this will not adequately protect the equipment from overloads.**

a. *CW Overload Relay Adjustment.* The overload relay in the equipment should be set to operate at approximately 425 ma during CW operation.

- (1) Remove the back panel to gain access to the high-voltage circuits. Bypass the interlock switches, which are opened by the removal of the panel.
- (2) Remove power amplifier tube V1 and clamper tube V2 from their sockets.  
**Caution: Be sure that the disconnected plate caps are insulated from ground to prevent the high-voltage power supply from being short-circuited. Use the test prod as a safety precaution.**
- (3) Connect an adjustable resistor-type dummy load with an adequate power rating and resistance (1,400 watts and 5,900 ohms) to high-voltage contact E4 (fig. 87) behind the RF deck. Connect the other end of the dummy load to the positive terminal of a 0-1 ampere dc ammeter; connect the negative terminal of the ammeter to ground.
- (4) Set the equipment for CW operation (par. 18 and 19, TM 11-809-10).
- (5) Turn the INCREASE CW (OVERLOAD RELAY ADJUSTMCNT R57) control (fig. 84) on the power supply deck fully clockwise

- (6) Reduce the dummy load resistance until it draws 425 ma as indicated on the ammeter.
- (7) Adjust the INCREASE CW control until the overload relay operates. At this time, the PLATE POWER indicator light should go out, and the dummy load current reading should drop to zero.
- (8) Operate the OVERLOAD RESET switch momentarily. The plate relay (K6) in the transmitter should close and immediately reopen.

*b. AM Overload Relay Adjustment.* The overload relay in the equipment should be set to operate at approximately 550 ma load current during AM operation.

- (1) Set up the transmitter and test equipment as described in *a* (1) through (3)
- (2) Set the equipment for AM operation (par. 18 and 20, TM 11-809-10).
- (3) Turn the INCREASE PHONE ( OVERLOAD RELAY ADJUSTMENT R56) control (fig. 84) on the power supply deck fully clockwise.
- (4) Reduce the dummy load resistance until it draws 550 ma as indicated on the ammeter.
- (5) Adjust the INCREASE PHONE control until the overload relay operates. At this time, the PLATE POWER indicator light should go out, and the dummy load current meter should drop to zero.
- (6) If no further adjustments are to be made, disconnect the test equipment, replace tubes V1 and V2 in their plate caps, disconnect the interlock bypasses, and replace the back cover.

#### 47. AM Power Measurement

The output power of the equipment is measured under AM operating conditions in the following procedure:

- a.* Connect the test audio oscillator to pins D used under AM operating conditions in the back of the housing). Adjust the oscillator for 1 kc at 0 decibel (db) referred to 1 milliwatt in 600 ohms (dbm)

*b.* Connect the watt meter between the RF OUTPUT receptacle and the output load.

*c.* Couple the transmitter output to the vertical deflection plates of the oscilloscope by means of a pickup coil. This is done by winding 2 to 4 turns of insulated wire (#14 gage, soft-drawn copper) over a winding space of 3 inches around coil L4 (on the RF deck). Connect the ends of the coil to the oscilloscope by means of a twisted pair line.

*d.* Set the equipment for AM operation.

*e.* Adjust the pickup coil for optimum response to give an adequate amplitude on the oscilloscope.

*f.* Adjust the 600 OHM LINE GAIN control for 100 percent modulation, as observed on the oscilloscope (fig. 96). The EXCITATION meter should read 8 ma (minimum) for P A GRID X2 and 70 ma ( maximum) or 20 ma (minimum) for INT AMP PLATE X10.

*g.* With the P A BAND SWITCH in the first four positions, the approximate power should be 470 watts between 1.5 and 11 mc; in the fifth position, the approximate power should be 440 watts between 11 and 18 mc, and 400 watts between 18 and 20 mc.

#### 48. CW Waveform and Power Test

(fig. 96)

The following test checks the output wave form and power during CW operation:

*a.* Replace the hand key with the reversal machine (dot keyer). Test Set 100-A is set for 22 dot cycles.

*b.* Set the equipment for CW operation (par. 18 and 19, TM 11-809-20).

*c.* Observe the output CW waveform on a test oscilloscope (use a pickup coil as previously described). The carrier amplitude (A + B) should not exceed the steady-state key-down amplitude (B) by more than 10 percent.

*d.* Replace the dot keyer with the hand key. Operate the hand key at a moderate speed. The sound (as heard on a headset) should be free from chirps, tails, and any other form of distortion. Hold the key down for about 10 seconds. There should be no change in pitch.

*e.* Measure the output power during CW operation (key down). Use a wattmeter in the

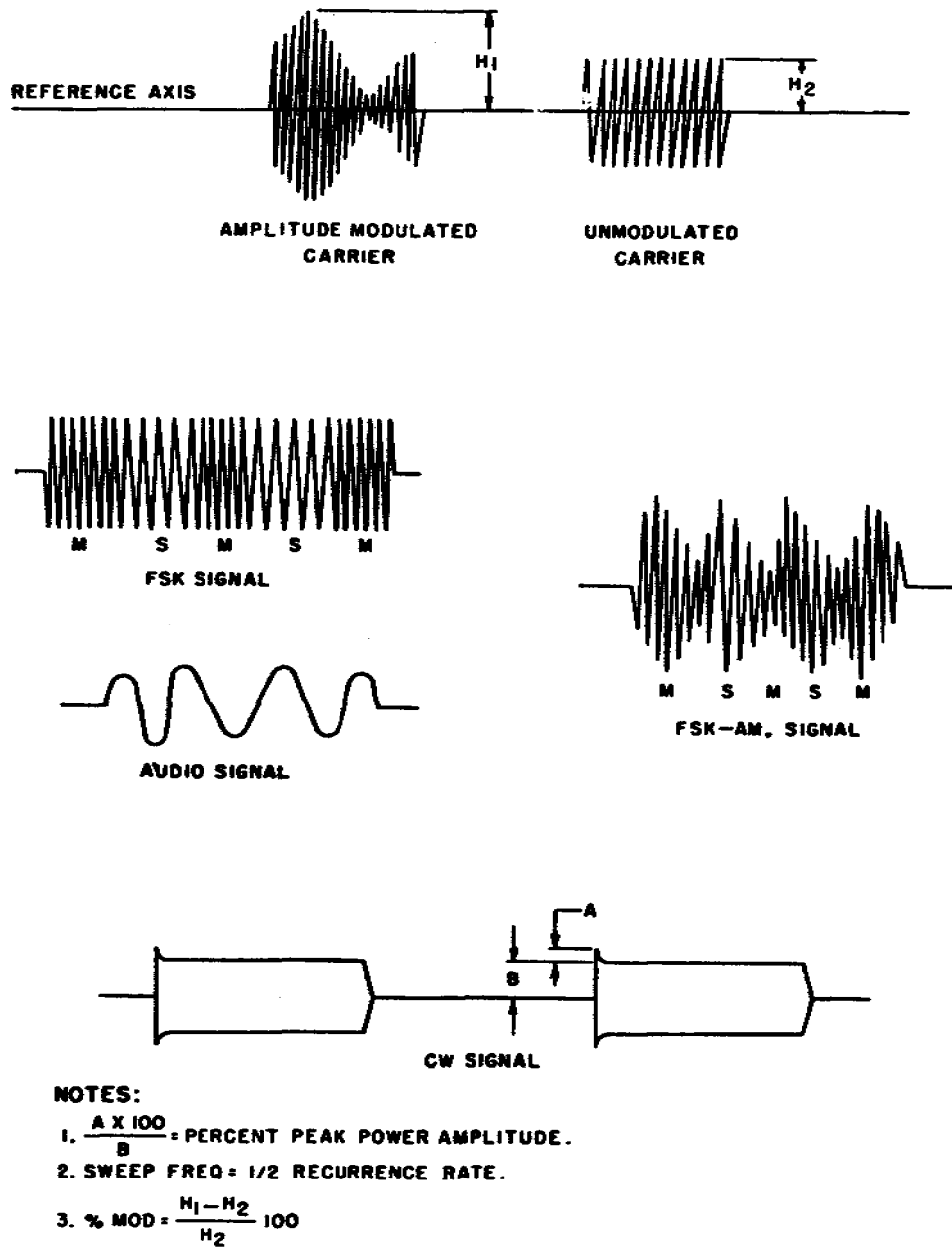

Figure 96. Waveforms.

antenna line, as described in paragraph 47b. The output power should be about 450 watts.

#### 49. AM Modulation Measurements

The modulation portion of the equipment is tested by the following procedures:

*a. Input Level Measurements.*

- (1) Use the audio oscillator and oscilloscope (connected to the equipment as

described for the AM power measurements, with a pickup coil).

- (2) Set the audio input level to -34 dbm. Turn the CARBON MIKE GAIN control fully counterclockwise to prevent the introduction of extraneous signals into the speech amplifier. By varying the 600-OHM LINE GAIN control, it should be possible to obtain 100 percent modulation.

- (3) Repeat the procedure in (2) above for an input level of +6 dbm.
- (4) Turn the 600 OHM LINE GAIN control fully counterclockwise. With an input level of +29 dbm, it should be possible to obtain 100 percent modulation by varying the CARBON MIKE GAIN control.
- (5) Repeat the procedure given in (4) above for an input level of +45 dbm.

*b. Residual Hum and Noise Measurement.*

- (1) With the audio oscillator connected for 600-ohm line operation (CARBON MIKE GAIN control turned down), adjust it for a 1-kc audio signal at 0 dbm.
- (2) Connect the spectrum analyzer to the pickup coil after disconnecting the test oscilloscope. Connect a vtm with a decibel (db) scale to the output of the linear detector.
- (3) Adjust the 600 OHM LINE GAIN control for 100 percent modulation. Note the reading on the db scale of the vtm.
- (4) Remove the audio oscillator signal. Terminate the 600-ohm line with a 600-ohm resistor. The vtm reading should be not less than 40 db below the previous reading obtained in (3) above.

*c. Input Frequency Measurements.*

- (1) With the audio oscillator connected for 600-ohm line operation (CARBON MIKE GAIN control turned down), adjust it for a 1-kc audio signal.
- (2) Adjust the 600 OHM LINE GAIN control for 40 percent modulation. This is done by observing the modulated wave on the oscilloscope for a height of 1.4 times the height of the unmodulated wave. Refer to note 3 on figure 96 for use of the modulation formula.
- (3) While varying the input signal frequency, measure the input power to obtain 40 percent modulation. The input power should have the following values for the given frequencies:

Input frequency (cps)	Output Power (dbm)
1,000	- Measured value.
500	Within 1.5 db of freq No. 1.
300	Within 1.5 db of freq No. 1.
100	+30 db greater than freq No. 1.
1,500	Within 1.5 db of freq No. 1.
2,500	Within 1.5 db of freq No. 1.
3,500	Within 1.5 db of freq No. 1.
5,500	+30 db greater than freq No. 1.

**50. AM or FSK-AM Distortion Measurement**

(fig. 96)

In the following tests, the distortion present in the amplitude modulated carrier is measured for different percentages of modulation:

- a. Connect the spectrum analyzer to the equipment.
- b. Adjust the equipment for 95 percent modulation with a 1-kc audio input. Make distortion measurements for the following modulation levels.

Modulation (percent)	Distortion (percent)
95	10 (max).
70	Less than that for 95 percent
30	Less than that for 70 percent
5	Less than that for 30 percent

**51. Stability Test**

The following test is made to determine if the equipment is free from spurious oscillations:

- a. Connect a 600-ohm resistor to the 600-ohm input line (pin D of J12); turn the 600 OHM LINE GAIN control down (fully counterclockwise). Turn the CARBON MIKE GAIN control up (fully clockwise). The static value of modulator plate current indicated on the EXCITATION meter (switch at MOD PLATE X20) should not increase.
- b. Repeat the above procedure for the carbon microphone line. Connect a 200-ohm resistor to the carbon microphone input at pin F of J12; turn the CARBON MIKE GAIN control down. Turn the 600 OHM LINE GAIN control up. The static value of modulator plate current should not increase.

c. Check for stability during CW operation. Set the equipment for CW operation and operate the hand key rapidly. The pa grid current should drop to zero (on the EXCITATION meter) when the key is up. The pa plate current should drop to its static value.

### 52. Antenna Relay and Receiver Disable Test

The following test checks the operation of the antenna changeover and receiver disabling features of the equipment:

- a. Set the equipment for CW operation.
- b. Close the hand key. The receiver connected to the RECEIVER receptacle (J10) should be disabled, assuming that it was operating before the hand key was operated. At the same time, the receiver is disconnected from the antenna line. In the key-down condition, the output of the sidetone oscillator should be heard in the monitoring headset. The PA PLATE and other meters should give their normal indications (for CW operation).

c. Release the hand key; the sidetone oscillations should cease, and the output of the transmitter should drop to zero. The receiver is then reconnected to the antenna line.

### 53. FSK Operational Test

The following test checks the FSK operation of the equipment. The test, at the same time, also checks the band-edge tuning to make certain that there are no major discrepancies in output between the end of one band and the beginning of the following band.

- a. Set the equipment for FSK operation (par. 22, TM 11-809-10).
- b. Apply FSK signals (fig. 96) to the FSK input receptacle (J16) at the following frequencies and control settings. Note the output power.

**Caution: When changing transmitter frequency, throw the TUNE-OPERATE switch (TUNE-NORMAL switch in A model and certain C model transmitters) to TUNE and keep it at TUNE while adjusting the POWER AMPLIFIER TUNING and POWER AMPLIFIER LOADING controls. Make the measurements with the switch at OPERATE (NORMAL).**

Input frequency ( mc )	BAND SELECTOR switch	P A BAND SWITCH ( mc )	Output frequency ( mc )	Minimum output power ( watts )
1.475	1.5-3.0	1.5-2.0	1.475	470
2.025	1.5-3.0	1.5-2.0	2.025	470
1.975	1.5-3.0	2.0-3.0	1.975	470
2.975	1.5-3.0	3.0-6.0	2.975	470
3.025	1.5-3.0	2.0-3.0	3.025	470
5.975	3.0-6.0	6.0-11.0	5.975	470
6.025	3.0-6.0	3.0-6.0	6.025	470
5.5125	6.0-12.0	6.0-11.0	11.025	470
5.4875	6.0-12.0	11.0-20.0	10.975	470
5.00625	12.0-20.0	11.0-20.0	20.025	400

### 54. External Excitation Operation Test

The following test checks the output power of the transmitter during EXT EXC operation:

- a. Adjust the transmitter for EXT EXC operation (par. 21, TM 11-809-10).
- b. Apply a maximum of 30 volts to the EXT EXC receptacle (J15).
- c. Use a wattmeter in the antenna line, as described in paragraph 47b to measure the output power. It should be at least 400 watts.

### 55. Speech Clipper Test

The following test checks the effectiveness of the speech clipper in the speech amplifier subassembly:

- a. Adjust the transmitter for AM operation.
- b. Connect a carbon microphone to the CARBON MICROPHONE receptacle (J11). Press the push-to-talk button on the microphone and speak into the microphone, while varying the setting of the CARBON MIKE GAIN control over its entire range. The modulator plate current reading on the EXCITATION meter should not exceed 230 ma for any setting of the gain control.

### 56. Safety Device Test

The following test checks the operation of the safety devices built into the transmitter:

- a. Remove high voltage from the equipment by throwing FILAMENT POWER and the PLATE POWER circuit breakers to OFF. Check with the test prod.

AGO 2742A

*b.* Connect the high-voltage probe of the multimeter to the high-voltage bus in the power supply deck.

*c.* Throw the PLATE POWER circuit breaker to ON, and the PLATE RELAY switch to on (up). The time delay relay in the equipment operates about 25 seconds after filament power has been applied. The presence of high voltage is indicated by the PLATE POWER indicator light going on and by a reading on the voltmeter connected to the probe.

*d.* In turn, slide out each deck. When a deck is withdrawn about 3/4 inch, high voltage is removed by the interlock switch, as indicated by the PLATE POWER indicator light going out. The voltmeter connected to the probe should indicate zero voltage.

*e.* Repeat the steps in *a* through *d* above, with the high-voltage probe connected to the modulator and RF deck side of the high-voltage bus.

*f.* Repeat the steps in *a* through *c* above. Remove the back cover of the housing. The high voltage should be removed by this action. Throw the PLATE POWER circuit breaker and the PLATE RELAY switch to their OFF positions. Replace the back cover.

*g.* Operate the FILAMENT POWER circuit breaker. Note that the blower (B2) in the housing operates only when the circuit breaker is thrown to the ON position.

*h.* At the conclusion of the tests, throw all switches and circuit breakers to their OFF positions. Use the test prod before disconnecting the high-voltage probe and all other test equipment.



## INDEX

	Paragraph	Page		Paragraph	Page
AF amplifier stages .....	9	17	Final testing-Continued		
AF driver stage .....	11	19	Safety device test.....	56	114
AF stage-gain chart .....	35	100	Speech clipper test .....	55	114
Alinement of multiplier subassembly .....	43	109	Stability test.....	51	113
AM modulation measurements .....	49	112	First buffer stage .....	3	4
AM or FSK-AM distortion measurements.	50	113	First multiplier stage .....	4	5
AM power measurements .....	47	111	First, second, and third AF amplifier stages.	9	17
Antenna changeover relay .....	18f	38	Fourth AF amplifier and AF driver stages.	11	19
Antenna relay and receiver disable test .....	52	114	FSK operational test.....	53	114
Antenna tuning unit theory .....	23	46	General precautions .....	28	83
Bias power supply .....	14	23	General troubleshooting instructions .....	24	48
Block diagram .....	2	2	High-voltage circuit .....	18e	38
Cathode follower stage .....	13	20	High-voltage power supply .....	17	32
Checking filament and B+ circuits for shorts.	29	84	Intermediate power amplifier stage .....	7	8
Clamper stage .....	8	14	Keying and slow release circuits .....	180	39
Clipper stage .....	10	18	Master oscillator and first buffer stages .....	3	4
Coil resistance .....	32	93	Meter resistances.....	32	93
Control circuits ( <i>see also</i> Primary power distribution).	18	36	Modulator stage .....	12	20
CW-phone relay K3 .....	18h	41	Multiplier stages:		
CW waveform and power test .....	48	111	First multiplier .....	4	5
Dc resistances of transformers, coils, relays, and meters	32	93	Second multiplier .....	5	6
Disassembly of drive mechanisms .....	38	102	Third multiplier .....	6	8
Drive mechanisms:			Operational test .....	30	84
Disassembly .....	38	102	Oscillator-multiplier and power amplifier tuning adjustments.	41	104
Reassembly .....	39	103	Oscillator-multiplier tuning drive mechanism.	20	44
Equipment necessary for final testing .....	45	110	Oscillator stage .....	3	4
Exciter power supply:			Overload protection circuits .....	19	43
A model transmitters .....	16	31	Overload relay adjustment .....	46	110
Basic, B. and C model transmitters .....	15	25	Plate relay circuit .....	18d	38
External excitation operational test .....	54	114	Power amplifier and clapper stages .....	8	14
External excitation relay K101 .....	18i	41	Power amplifier tuning drive:		
Final testing:			Adjustments .....	41	104
AM modulation measurements .....	49	112	Mechanism .....	21	44
AM or FSK-AM distortion measurements.	50	113	Power supplies:		
AM power measurement .....	47	111	Bias .....	14	23
Antenna relay and receiver disable test.	52	114	Exciter (A model transmitters) .....	16	31
CW waveform and power test .....	48	111	Exciter (basic, B. and C model transmitters).	15	25
Equipment needed .....	45	110	High voltage .....	17	32
External excitation operational test .....	54	114	Precautions .....	28	83
FSK operational test .....	53	114	Primary power distribution and control circuits:		
Overload relay adjustment .....	46	110	Antenna changeover relay .....	18f	38
Purpose .....	44	110	CW-phone relay K3 .....	18h	41
Receiver disable test .....	52	114			

	Paragraph	Page		Paragraph	Page
Primary power distribution and control circuits-Continued			Service selector switch S1-Continued		
External excitation relay KIG1 .....	18i	41	B and C model transmitters .....	18l	43
Filament power circuit breaker CB1 .....	18a	36	Basic model transmitters .....	18j	41
High voltage circuit .....	18e	38	Servicing antenna tuning unit .....	42	104
Keying and slow release circuits .....	18g	39	Sidetone oscillator and cathode follower .....	13	20
Overload protection circuit .....	19	43	stages.		
Plate relay circuit .....	18d	38	Signal substitution .....	34	97
Service selector switch S1 .....	18j-l	41	Signal substitution notes .....	33	94
Switch S6 .....	18b	37	Speech clipper test .....	55	114
Time delay circuit .....	18c	37	Stability test .....	51	113
Purpose of final testing .....	44	110	Stage-gain chart .....	35	100
Reassembly of drive mechanism .....	39	103	Subassemblies:		
Receiver disable test .....	52	114	Removal .....	37	101
Relay resistances .....	32	93	Replacement .....	40	104
Removal of subassemblies .....	37	101	Test equipment required for trouble .....	27	83
Replacement of parts .....	36	101	shooting.		
Replacement of subassemblies .....	40	104	Third multiplier stage .....	6	8
Safety device test .....	56	114	Time delay circuit .....	18c	37
Scope .....	1	2	Transformer resistances .....	32	93
Second buffer and first multiplier stage .....	4	5	Troubleshooting:		
Second multiplier stage .....	5	6	Chart .....	31	85
Service selector switch S1:			Data.....	26	49
A model transmitters .....	18k	42	Instructions, general .....	24	48
			Procedures .....	25	48

[AG 413.44 (30 Sep 58) ]

BY ORDER OF THE SECRETARIES OF THE ARMY AND THE AIR FORCE:

OFFICIAL:

R. V. LEE,  
Major General, United States Army  
The Adjutant General.

MAXWELL D. TAYLOR  
General, United States Army,  
Chief of Staff.

OFFICIAL:

J. L. TARR,  
Colonel, United States Air Force,  
Director of Administrative Services.

THOMAS D. WHITE,  
Chief of Staff, United States Air Force.

DISTRIBUTION:

Active Army:

ASA (2)  
CNGB (1)  
Technical Stf, DA (1) except CSigO (30)  
Technical Stf Bd (1)  
USCONARC (5).  
USA Arty Bd (1)  
USA Armor Bd (1)  
USA Inf Bd (1,  
USA Air Def Bd (1)  
USA Abn & Elct Bd (1)  
USA Avn Bd (1)  
USA Armor Bd Test See (1)  
USA Air Def Bd Test See (1)

USA Arctic Test Bd (1)  
US ARADCOM (2)  
US ARADCOM Rgn (2)  
OS Maj Comd (6)  
Log Comd (5)  
MDW (1)  
Armies (5)  
Corps (2)  
Div (2)  
USATC (2)  
Svc Colleges (6)  
Br Svc Sch (6) except USASCS (25)-  
Gen Depots (2) except Atlanta Gen Depot  
(None)  
Sig Sec. Gen Depots (10)

Sig Depots (17)	USA Corps (Res) (1)
Army Pictorial Cen (2)	JBUSMC (2t)
Engr Maint Cen (1)	Units org under fol TOE: 11-5 (2)
TASSA (15)	11-7 (2)
Mid-Western Rgn Of c (TASSA) (1)	11-15 (2)
USA Sig Pub Agcy (8)	11-16 (2)
USA Sig Engr Agcy (1)	11-17 (2)
USA Comm Agcy (2)	11-18 (2)
USA Sig Eqp Spt Agcy (2)	11-37 (2)
USA Sig Msl Spt Agcy (13)	11-55 (2)
WRAMC (1)	11-57 (2)
AFIP (1)	11-85 (2)
AMS (1)	11-87 (2)
Ports of Emb (OS) (2)	11-95 (2)
Trans Terminal Comd (2)	11-98 (2)
Army Terminals (2)	11-99 (2)
OS Sup Agey (2)	11-117 (2)
Yuma Test Sta (2)	11-500 (TM AA-AK) (2)
USA Elct PG (1)	11-637 (2)
Sig Lab (5)	11-567 (2)
Sig Fld Maint Shops (3)	11-687 (2)
Fld Comd, AFSWP (5)	11-692 (2)
Mil Dist (1)	11-597 (2)
Sector Comd, USA Corps (Res) (1)	

*NG*: State AG (3); units-same as Active Army except allowance

*USAR*: None.

For explanation of abbreviations used, see AR 320-50.

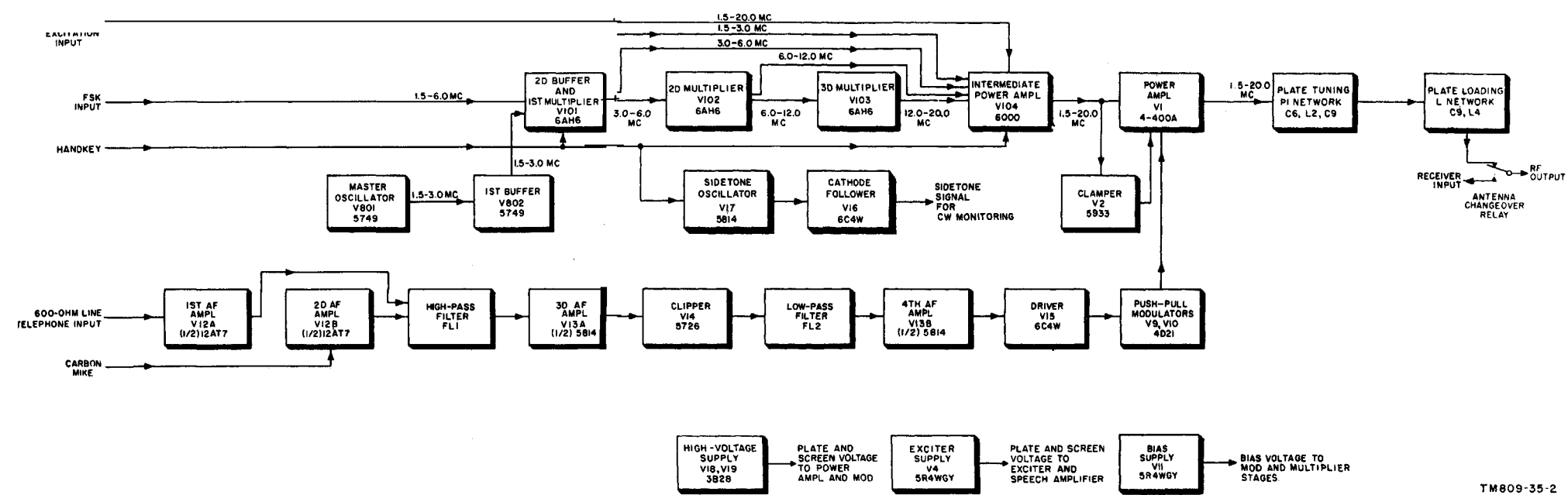

TM809-35-2

Figure 1. Basic transmitter, block diagram.

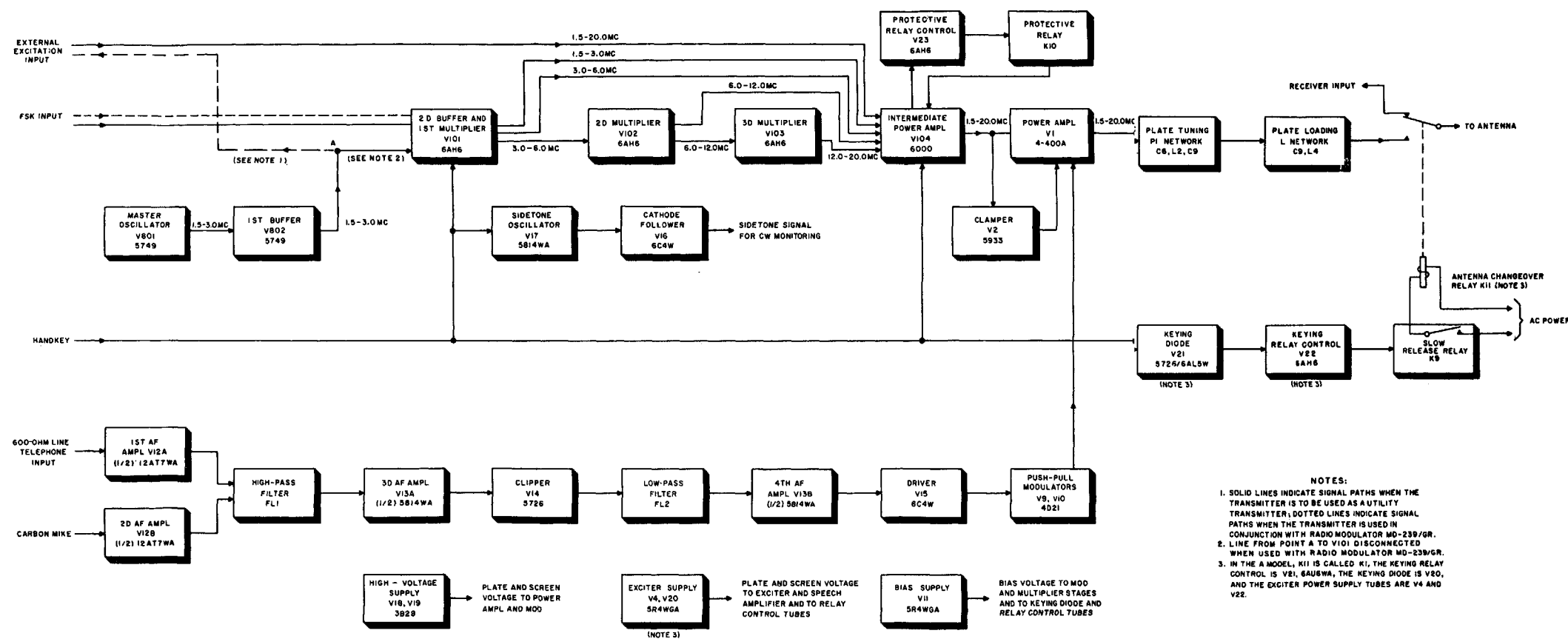

Figure 2. Letter model transmitter, block diagram.

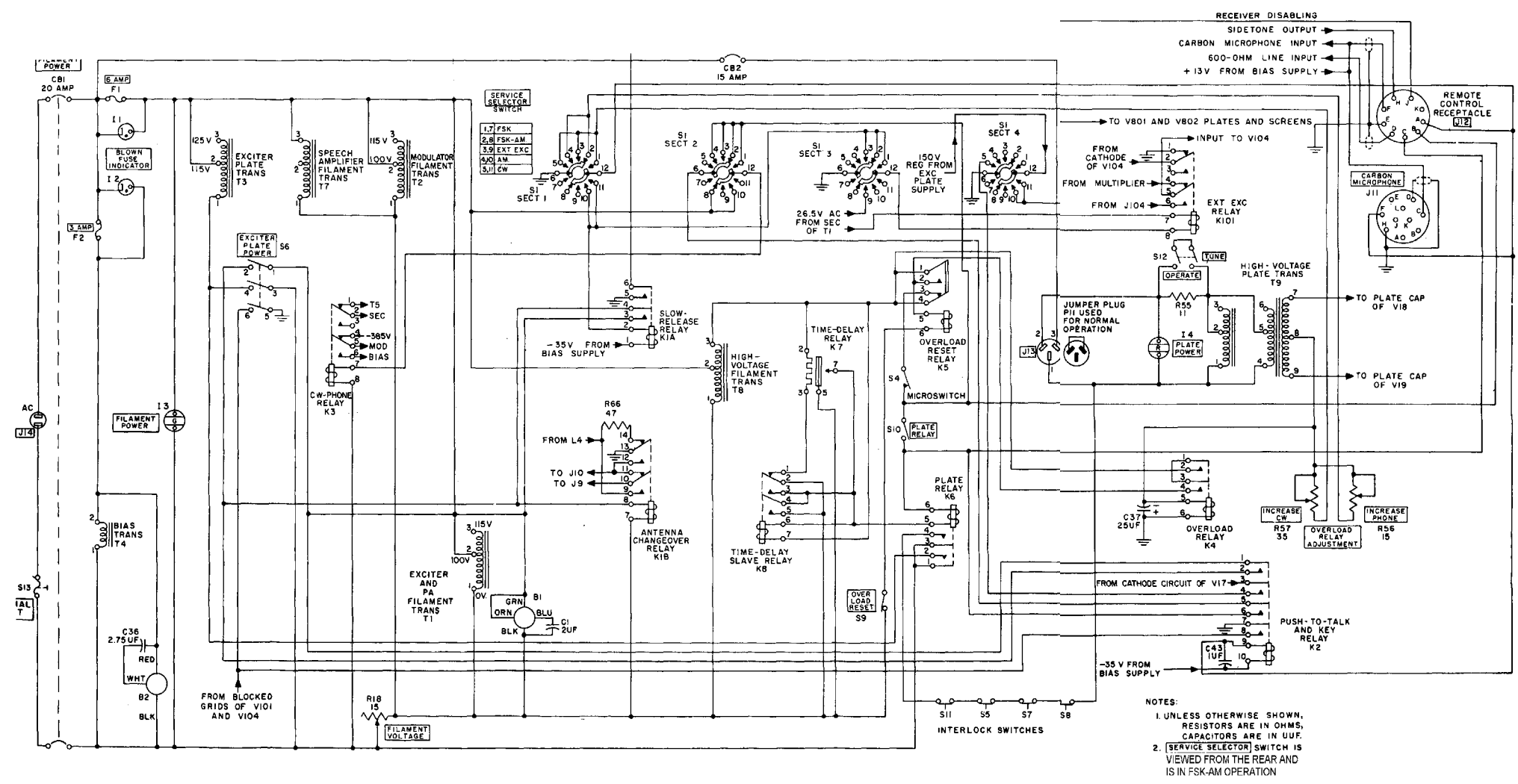

Figure 28. Primary power distribution and control circuits, basic model transmitters.

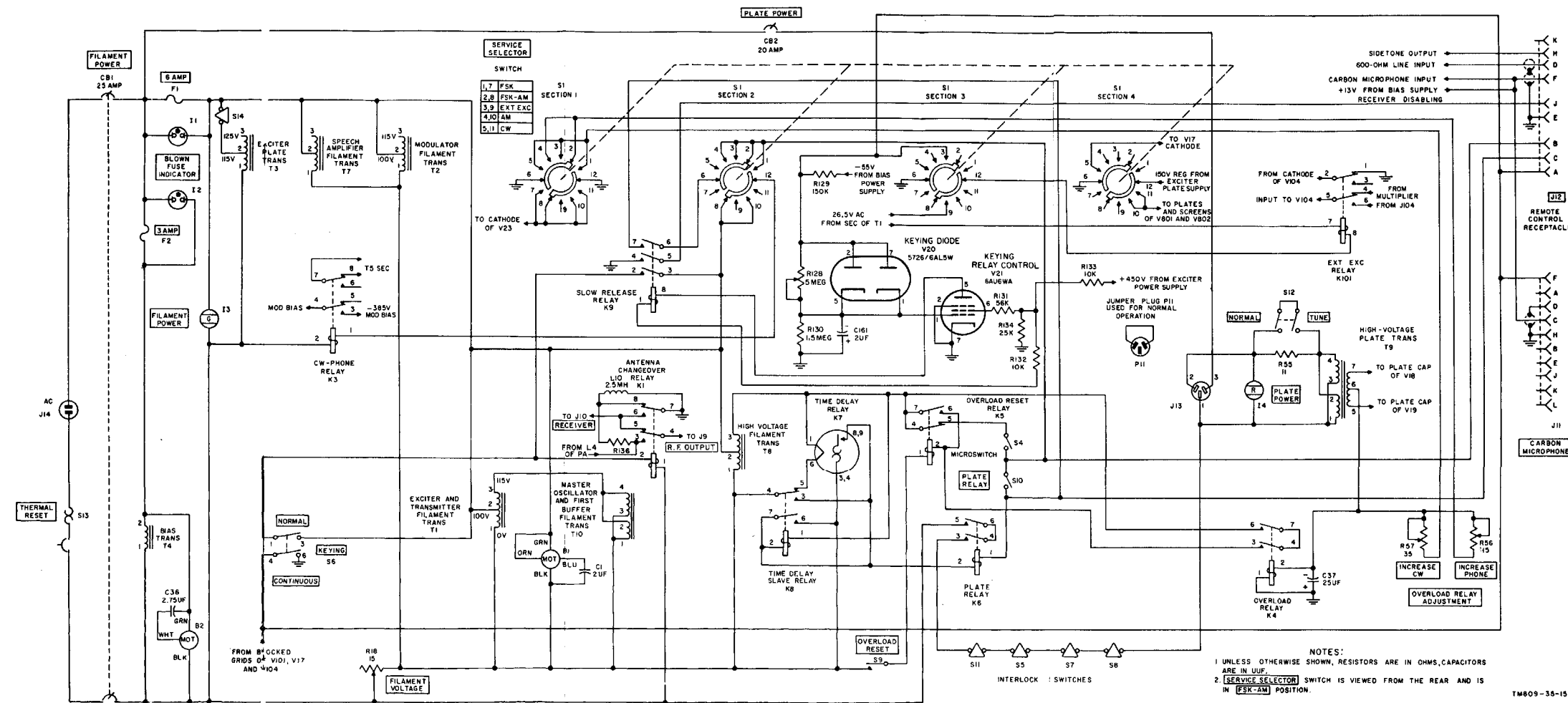

Figure 29. Primary power distribution and control circuits, A model transmitters.

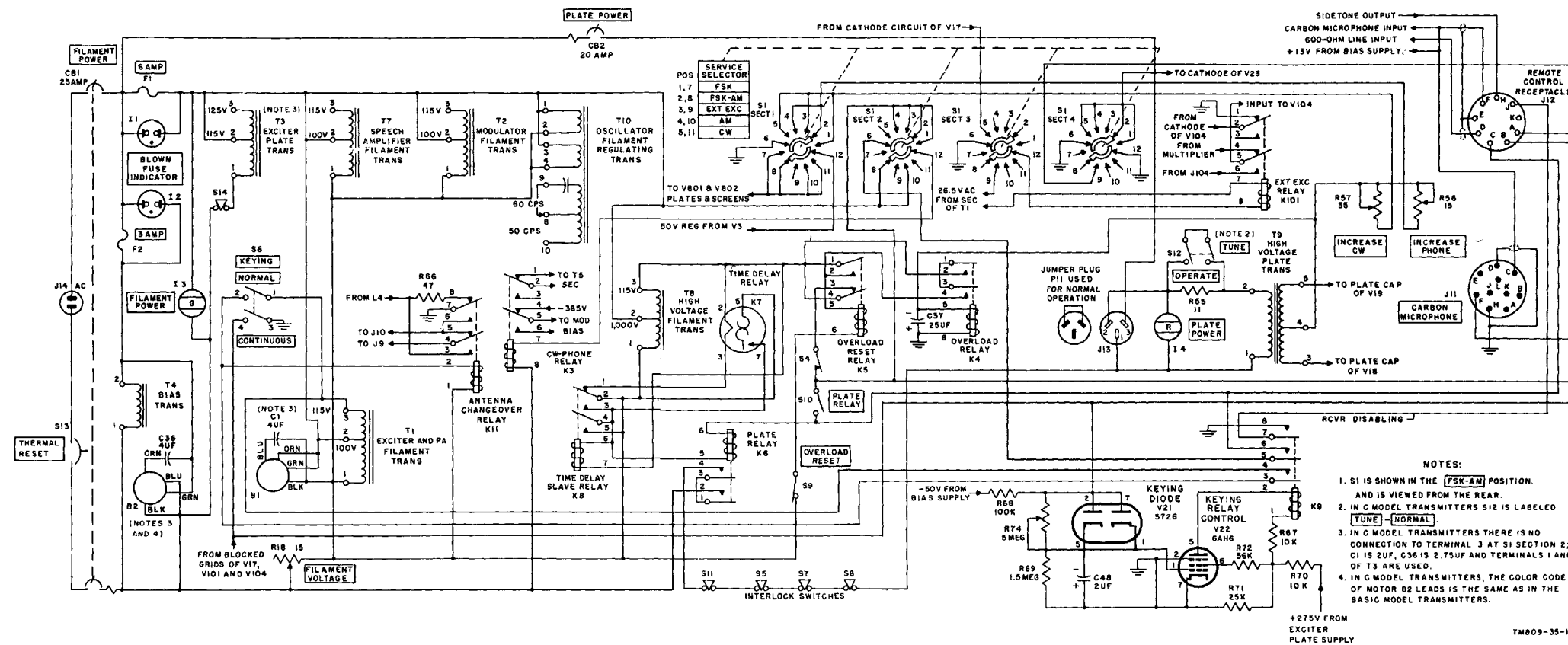

Figure 30. Primary power distribution and control circuits, B and C model transmitter.



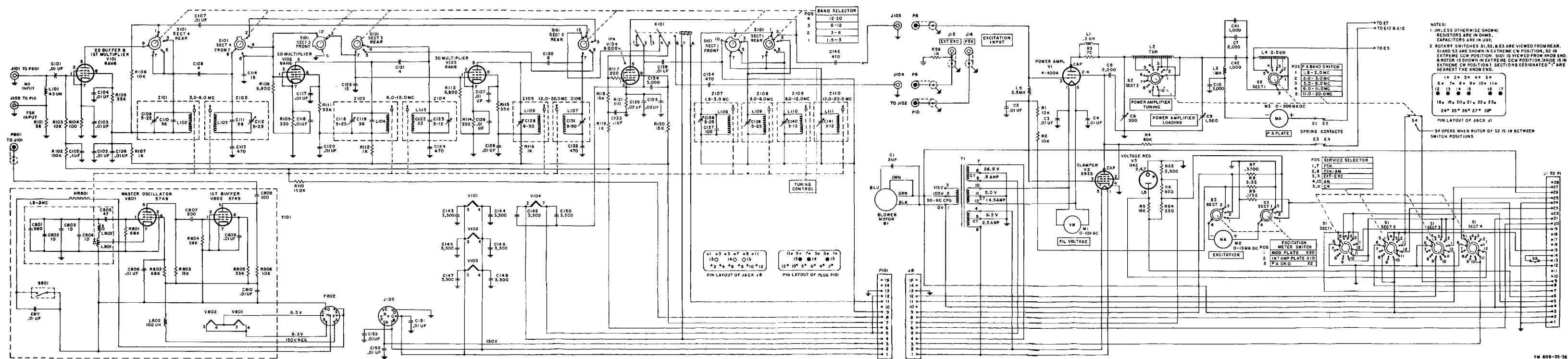

Figure 97. Basic transmitter, schematic diagram of RF deck.

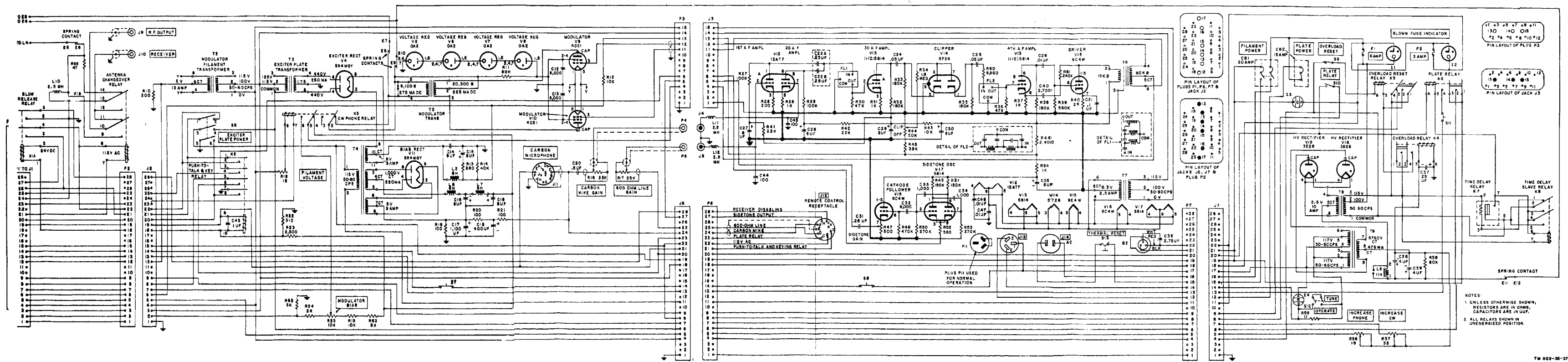

Figure 98. Basic transmitter, schematic diagram of modulator deck, power deck, and housing

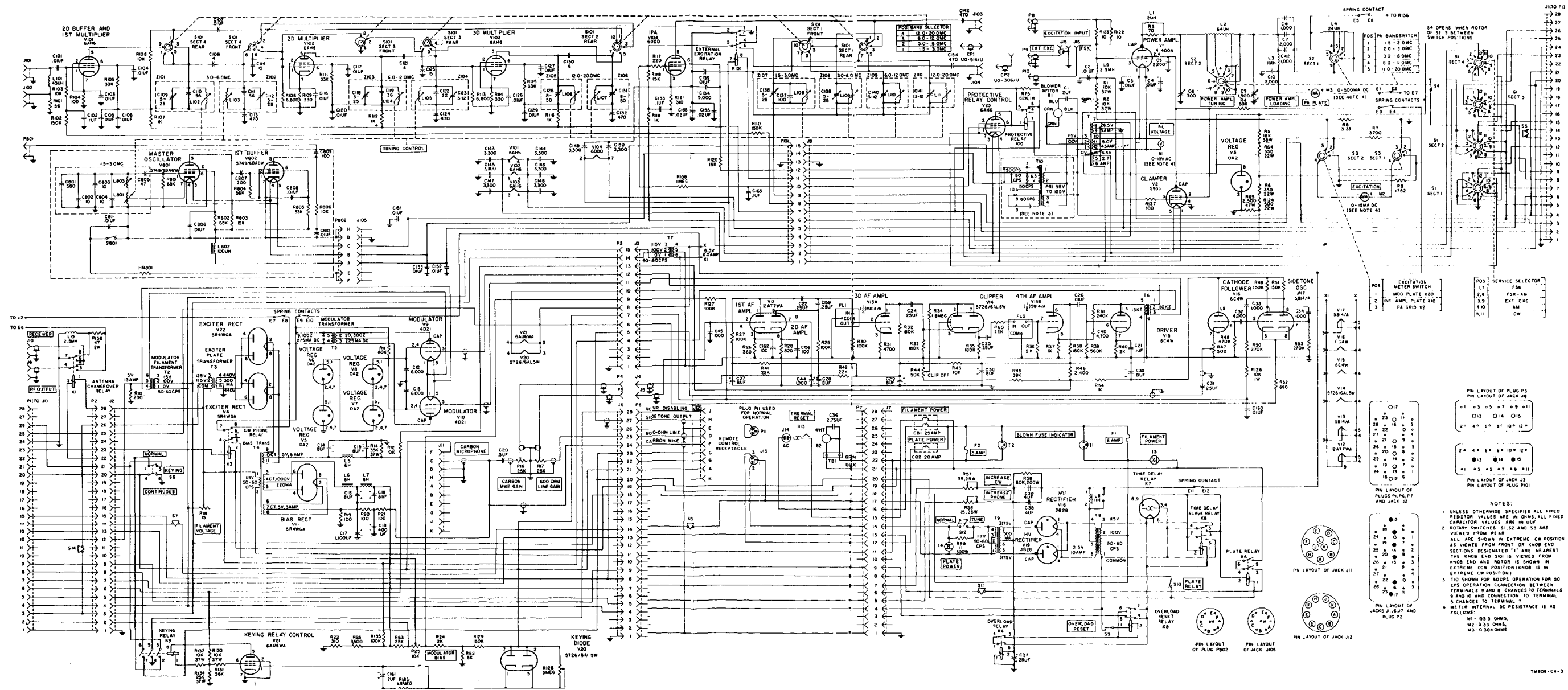

Figure 99. A model transmitter, complete schematic diagram.

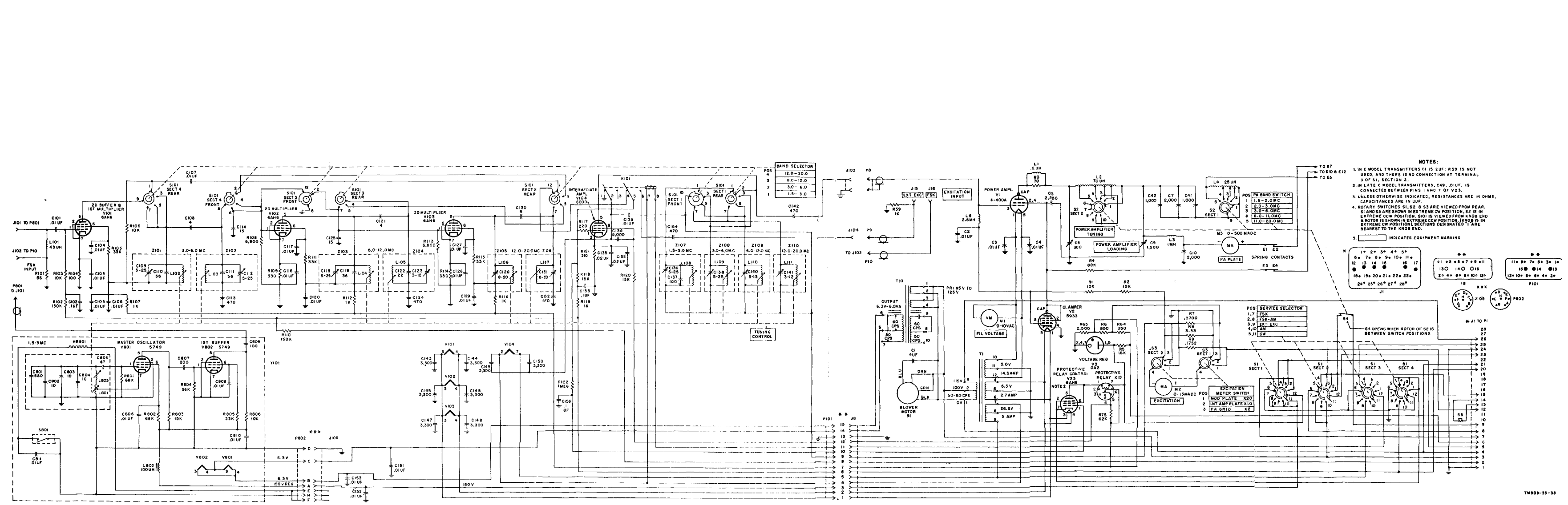

Figure 100. B and C model transmitters, schematic diagram of RF deck.

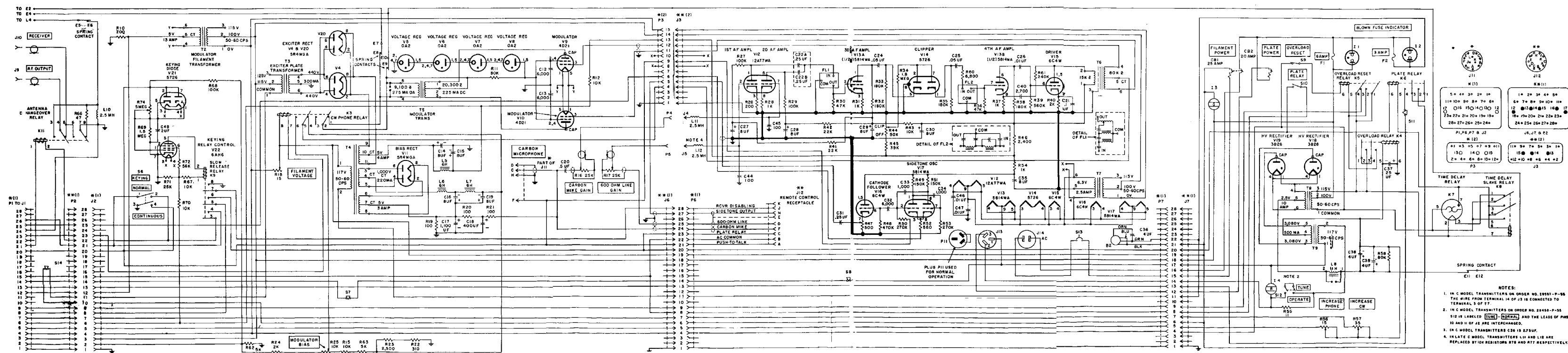

Figure 101. B and C model transmitters, schematic diagram of modulator deck, power deck, and housing.

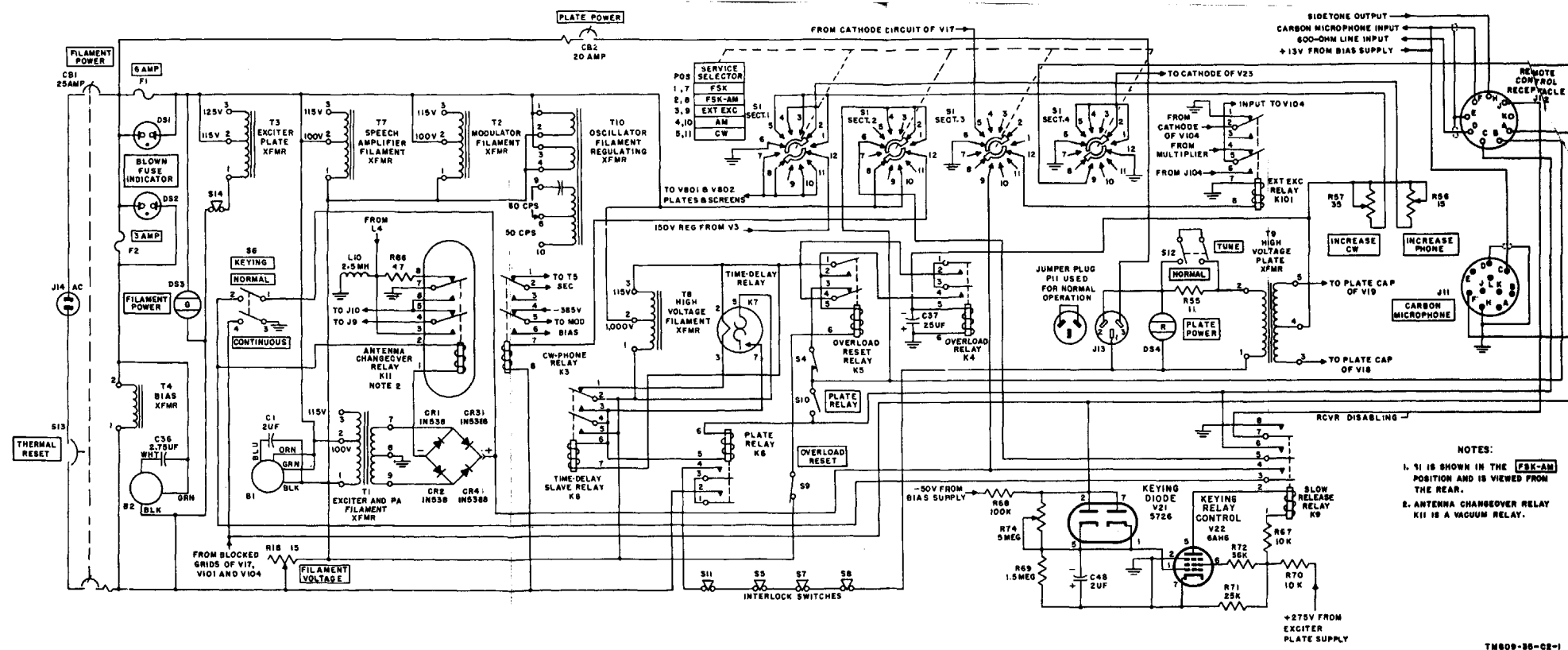

Figure 30.1. (Added) Primary power distribution and control circuits, E model transmitters.

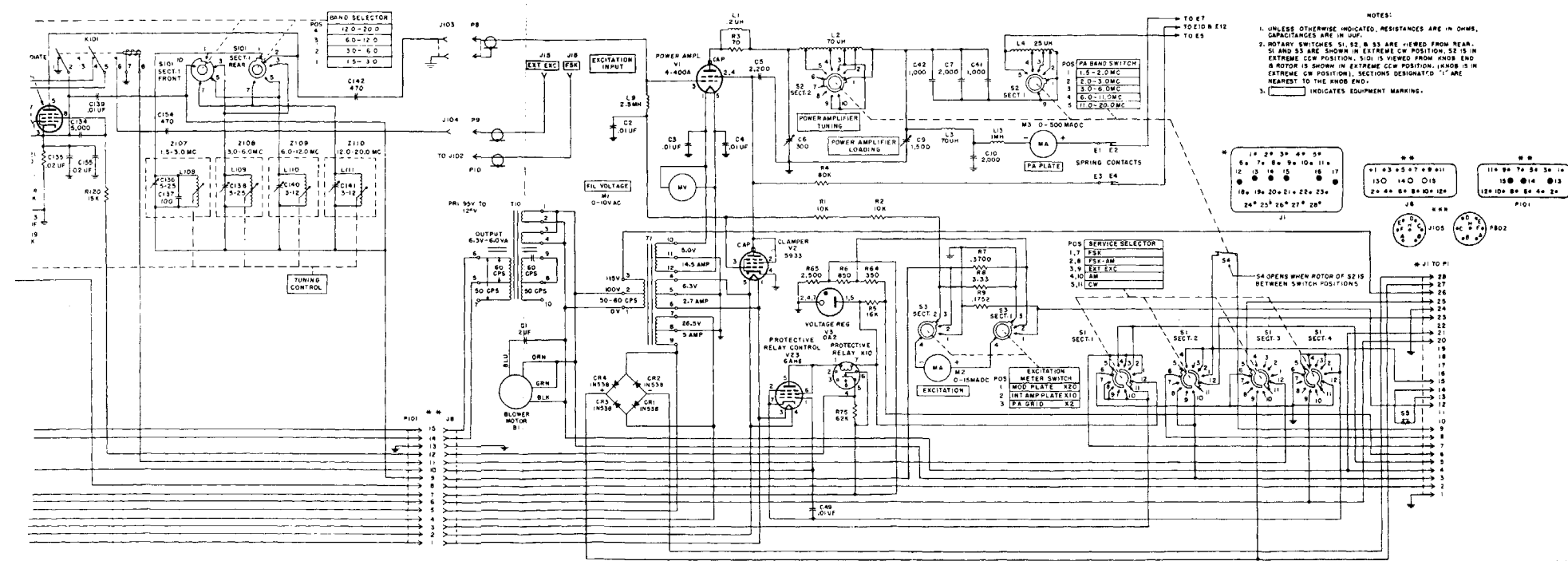

Figure 102. (Added) E model transmitters, rf deck, schematic diagram.

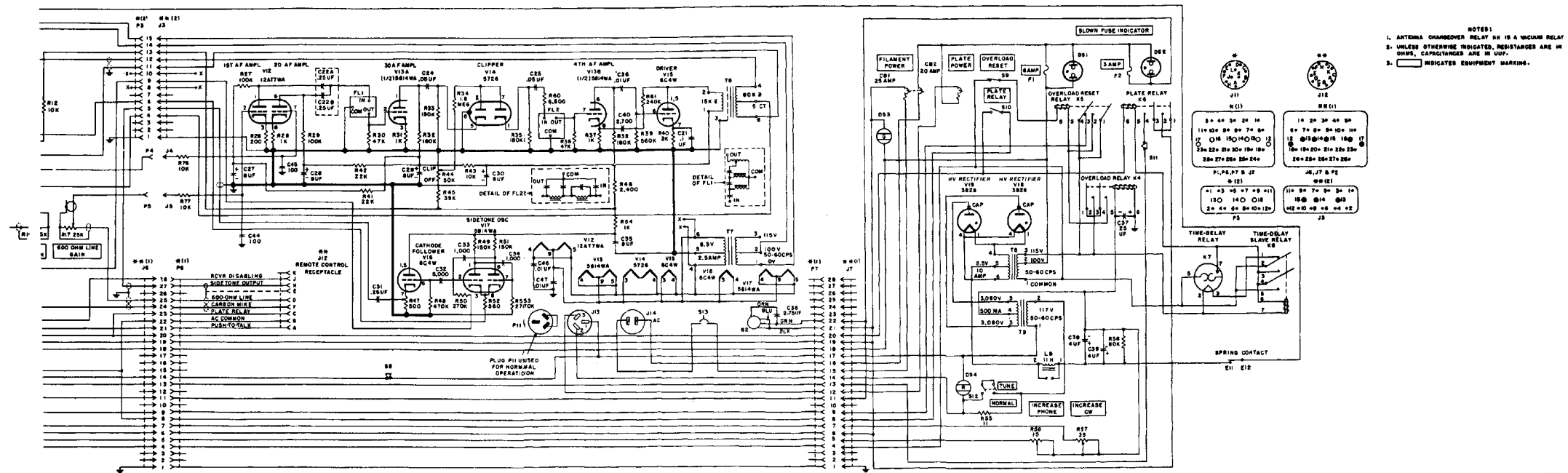

Figure 103 (Added) E model transmitters, modulator deck, power deck, and housing, schematic diagram.



RECOMMENDED CHANGES TO EQUIPMENT TECHNICAL PUBLICATIONS



THEN...JOT DOWN THE  
DOPE ABOUT IT ON THIS FORM.  
CAREFULLY TEAR IT OUT, FOLD IT  
AND DROP IT IN THE MAIL.

SOMETHING WRONG WITH PUBLICATION

FROM: (PRINT YOUR UNIT'S COMPLETE ADDRESS)

DATE SENT

PUBLICATION NUMBER

PUBLICATION DATE

PUBLICATION TITLE

BE EXACT PIN-POINT WHERE IT IS

PAGE  
NO.

PARA-  
GRAPH

FIGURE  
NO.

TABLE  
NO.

IN THIS SPACE, TELL WHAT IS WRONG  
AND WHAT SHOULD BE DONE ABOUT IT.

TEAR ALONG PERFORATED LINE

PRINTED NAME, GRADE OR TITLE AND TELEPHONE NUMBER

SIGN HERE

